

PIPING DIAGRAM FOR BAXI BOILERS WITH 1/2" DUAL CHECK VALVE

REQUIRED AT BOILER

GAS

WATER

POWER 10AMP G.P.O.

TWIN ACTIVE THERMOSTAT WIRE

FRONT

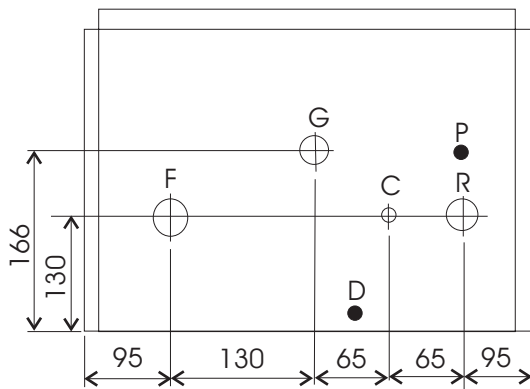

F: Heating system flow 3/4" M.I.

G: Gas inlet 3/4" M.I.

C: Domestic cold water inlet 1/2" M.I.

R: Heating system return 3/4" M.I.

P: Pressure relief valve 1/2" F.I.
(run in copper to drain)

D: Condensation drain Luna3 HT
(run in plastic to sewer)

1/2" DUAL CHECK VALVE
BACKFLOW PREVENTER
LOW HAZARD NO CHEMICAL DOSING

BAXI 1240Fi & 1310Fi

VIEW FROM FRONT

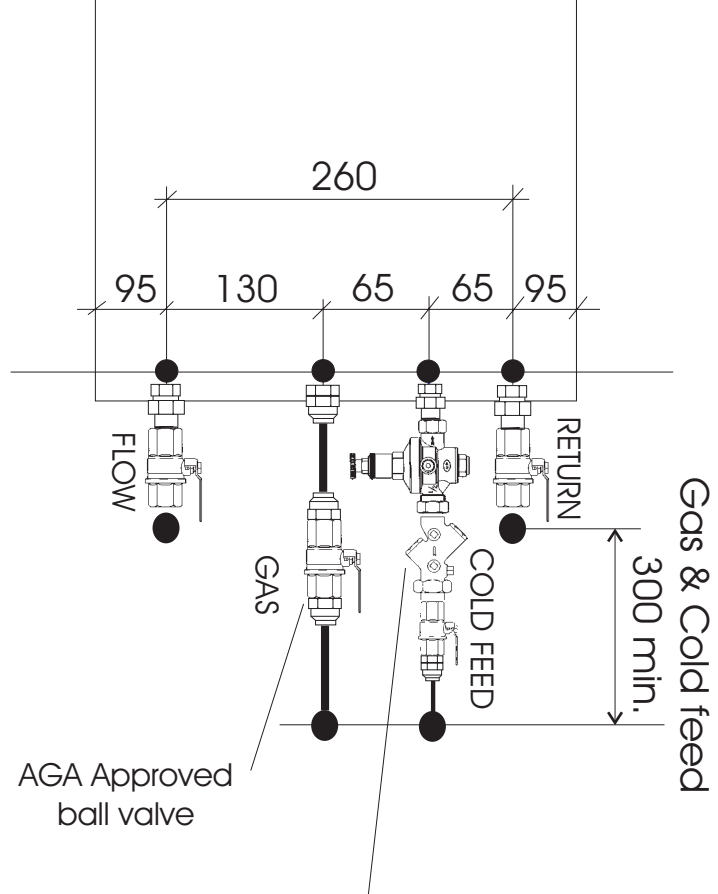

NOTE:
WARRANTY IS VOID,
IF SYSTEM IS NOT
CLEANED AND FLUSHED



Hydroheat Supplies Pty Ltd
Ph 9588 1299 Fax 9588 2199