

# SIEMENS



ALBATROS 

## RVA47.320

# Cascade Controller for modulating gas-fired Boilers

## Basic Documentation

Edition 2.0  
Controller series B  
CE1P2379E  
27.09.1999

Siemens Building Technologies  
Landis & Staefa Division



# Contents

|       |                                                    |    |
|-------|----------------------------------------------------|----|
| 1     | Summary .....                                      | 8  |
| 1.1   | Brief description .....                            | 8  |
| 1.2   | Features.....                                      | 9  |
| 1.3   | Range of products.....                             | 11 |
| 1.4   | Field of use .....                                 | 12 |
| 1.5   | Product liability .....                            | 12 |
| 2     | Handling.....                                      | 13 |
| 2.1   | Installation.....                                  | 13 |
| 2.1.1 | Mounting location.....                             | 13 |
| 2.1.2 | Regulations for installation .....                 | 13 |
| 2.1.3 | Mounting procedure .....                           | 13 |
| 2.1.4 | Required cutout.....                               | 15 |
| 2.1.5 | Orientation .....                                  | 15 |
| 2.2   | Electrical installation .....                      | 16 |
| 2.2.1 | Regulations for installation .....                 | 16 |
| 2.2.2 | Wiring.....                                        | 16 |
| 2.3   | Commissioning .....                                | 18 |
| 2.3.1 | Functional checks .....                            | 18 |
| 2.4   | Parameter settings for the end-user.....           | 22 |
| 2.4.1 | Overview of end-user parameters.....               | 23 |
| 2.5   | Parameter settings for the heating engineer .....  | 24 |
| 2.5.1 | Overview of heating engineer parameters .....      | 25 |
| 2.6   | Parameter settings for the OEM.....                | 28 |
| 2.6.1 | Overview of OEM parameters.....                    | 30 |
| 2.7   | Operation .....                                    | 32 |
| 2.7.1 | Operating elements.....                            | 32 |
| 2.8   | Operational faults.....                            | 33 |
| 3     | Description of end-user settings.....              | 34 |
|       | <i>User interface</i> .....                        | 34 |
| 3.1   | Operating modes of heating circuit .....           | 34 |
| 3.2   | Operating mode of d.h.w. heating .....             | 36 |
| 3.3   | Nominal room temperature setpoint.....             | 37 |
| 3.4   | Manual operation .....                             | 39 |
|       | <i>Setting the clock</i> .....                     | 40 |
| 3.5   | Time of day .....                                  | 40 |
| 3.6   | Weekday .....                                      | 40 |
|       | <i>Time switch program for space heating</i> ..... | 41 |
| 3.7   | Preselection of weekday .....                      | 41 |
| 3.8   | Switching times .....                              | 43 |
|       | <i>D.h.w. values</i> .....                         | 44 |
| 3.9   | Nominal setpoint of d.h.w. temperature .....       | 44 |

|      |                                                                          |    |
|------|--------------------------------------------------------------------------|----|
|      | <i>Heating circuit values</i> .....                                      | 45 |
| 3.10 | Reduced room temperature setpoint .....                                  | 45 |
| 3.11 | Frost protection setpoint of the room temperature .....                  | 46 |
| 3.12 | Summer / winter changeover temperature of the heating circuit .....      | 47 |
| 3.13 | Slope of heating curve .....                                             | 49 |
|      | <i>Actual values</i> .....                                               | 51 |
| 3.14 | Actual value of room temperature .....                                   | 51 |
| 3.15 | Actual value of outside temperature .....                                | 51 |
|      | <i>Maintenance</i> .....                                                 | 52 |
| 3.16 | Standard time switch program for heating circuit and d.h.w. ....         | 52 |
|      | <i>Time switch program for d.h.w. heating</i> .....                      | 53 |
| 3.17 | Preselection of weekday .....                                            | 53 |
| 3.18 | Switching times .....                                                    | 54 |
|      | <i>Service</i> .....                                                     | 55 |
| 3.19 | Indication of BMU error code .....                                       | 55 |
| 3.20 | Indication of faults .....                                               | 56 |
| 4    | Description of heating engineer settings .....                           | 58 |
|      | <i>Service values</i> .....                                              | 58 |
| 4.1  | Output test .....                                                        | 58 |
| 4.2  | Input test .....                                                         | 59 |
| 4.3  | Display of plant type .....                                              | 60 |
| 4.4  | Display of PPS communication .....                                       | 62 |
|      | <i>Actual values</i> .....                                               | 64 |
| 4.5  | Actual boiler temperature values of BMUs (TKx) .....                     | 64 |
| 4.6  | Actual value of cascade flow temperature .....                           | 65 |
| 4.7  | Actual value of cascade return temperature .....                         | 66 |
| 4.8  | Actual value of buffer storage tank temperature .....                    | 67 |
| 4.9  | Actual value of d.h.w. temperature (TBWx) .....                          | 67 |
| 4.10 | Attenuated outside temperature .....                                     | 68 |
| 4.11 | Composite outside temperature .....                                      | 69 |
| 4.12 | Outside temperature source .....                                         | 70 |
|      | <i>Setpoints</i> .....                                                   | 71 |
| 4.13 | Setpoint of the boiler temperature of BMUs .....                         | 71 |
| 4.14 | Setpoint of the cascade flow temperature .....                           | 72 |
| 4.15 | D.h.w temperature setpoint .....                                         | 73 |
| 4.16 | Nominal room temperature setpoint .....                                  | 74 |
| 4.17 | Room temperature setpoint .....                                          | 75 |
| 4.18 | Flow temperature setpoint .....                                          | 76 |
|      | <i>Heat generation values</i> .....                                      | 77 |
| 4.19 | Existing boilers .....                                                   | 77 |
| 4.20 | Display lead boiler .....                                                | 78 |
| 4.21 | Remaining number of operating hours for changeover of boiler sequence .. | 79 |

|        |                                                                                     |     |
|--------|-------------------------------------------------------------------------------------|-----|
| 4.22   | Burner operating hours BMU 1 – 4 .....                                              | 79  |
| 4.23   | Minimum limitation of boiler temperature TKmin .....                                | 80  |
| 4.24   | Nominal output of BMU 1 - 4.....                                                    | 81  |
|        | <i>Configuration of plant</i> .....                                                 | 82  |
| 4.25   | Pump function output Q1 .....                                                       | 82  |
| 4.26   | Use of sensor input B70/B4 .....                                                    | 83  |
|        | <i>Space heating</i> .....                                                          | 85  |
| 4.27   | Parallel displacement of heating curve .....                                        | 85  |
| 4.28   | Gain factor for room temperature influence.....                                     | 86  |
| 4.29   | Switching differential of room temperature.....                                     | 87  |
| 4.30   | Minimum limitation of flow temperature setpoint .....                               | 89  |
| 4.31   | Maximum limitation of flow temperature setpoint .....                               | 90  |
| 4.32   | Type of building construction .....                                                 | 91  |
| 4.33   | Adaptation of heating curve .....                                                   | 92  |
|        | <i>D.h.w. values</i> .....                                                          | 94  |
| 4.34   | Reduced setpoint of d.h.w. temperature .....                                        | 94  |
| 4.35   | Release of d.h.w. heating .....                                                     | 95  |
| 4.35.1 | 24-hour operation <i>Setting 0</i> .....                                            | 95  |
| 4.35.2 | Operation according to heating program(s) with forward shift <i>Setting 1</i> ..... | 96  |
| 4.35.3 | Operation according to d.h.w. time switch program <i>Setting 2</i> .....            | 96  |
| 4.36   | Switching program for circulating pump .....                                        | 97  |
| 4.37   | Assignment of d.h.w. heating .....                                                  | 98  |
| 4.38   | Number of d.h.w. charging cycles .....                                              | 99  |
| 4.38.1 | Once per day with a forward shift of 2.5 hours <i>Setting 0</i> .....               | 99  |
| 4.38.2 | Several times per day with a forward shift of 1 hour <i>Setting 1</i> .....         | 99  |
| 4.39   | Type of d.h.w. demand .....                                                         | 100 |
| 4.40   | Boost of flow temperature setpoint for d.h.w. ....                                  | 102 |
| 4.41   | D.h.w. priority .....                                                               | 103 |
| 4.41.1 | Shifting priority .....                                                             | 104 |
| 4.42   | Demand for heat with reduced d.h.w. setpoint .....                                  | 106 |
|        | <i>Cascade settings</i> .....                                                       | 107 |
| 4.43   | Changeover of boiler sequence in cascades .....                                     | 107 |
| 4.44   | Exemption from automatic changeover of the boiler sequence.....                     | 108 |
| 4.45   | Lead boiler with a fixed changeover of the boiler sequence.....                     | 109 |
| 4.46   | Switch-on delay lag boilers .....                                                   | 110 |
| 4.47   | Restart lock of BMUs .....                                                          | 110 |
|        | <i>LPB / system</i> .....                                                           | 111 |
| 4.48   | LPB device address .....                                                            | 111 |
| 4.49   | LPB segment address.....                                                            | 112 |
| 4.50   | Bus power supply.....                                                               | 113 |
| 4.51   | Display of LPB power supply .....                                                   | 114 |
| 4.52   | Display of LPB communication .....                                                  | 114 |
| 4.53   | Range of action of central changeover .....                                         | 115 |
| 4.54   | Automatic summer / winter changeover .....                                          | 116 |

|        |                                                                                                    |     |
|--------|----------------------------------------------------------------------------------------------------|-----|
| 4.55   | Central standby switch .....                                                                       | 117 |
| 4.56   | Clock mode .....                                                                                   | 118 |
|        | <i>Input H1</i> .....                                                                              | 119 |
| 4.57   | Input H1.....                                                                                      | 119 |
| 4.57.1 | Changeover of operating mode (remote telephone switch) <i>Setting 0 / 1</i> ....                   | 120 |
| 4.57.2 | Minimum setpoint of flow temperature - contact H1<br>see operating line 171 <i>Setting 2</i> ..... | 121 |
| 4.57.3 | Heat generation lock <i>Setting 3</i> .....                                                        | 121 |
| 4.57.4 | Demand for heat <i>Setting 4</i> .....                                                             | 122 |
| 4.58   | Minimum setpoint of flow temperature - contact H1 .....                                            | 123 |
| 4.59   | Maximum value of heat demand signal DC 0...10 V (H1).....                                          | 124 |
| 4.60   | Operating action of contact connected to H1 .....                                                  | 124 |
| 5      | Description of OEM settings.....                                                                   | 125 |
|        | <i>Heat generation values OEM</i> .....                                                            | 125 |
| 5.1    | Minimum limitation of boiler temperature setpoint (TKmin <sub>OEM</sub> ) .....                    | 125 |
| 5.2    | Maximum limitation of boiler temperature setpoint .....                                            | 126 |
| 5.3    | Pump overrun time.....                                                                             | 127 |
| 5.4    | Minimum limitation of boiler return temperature .....                                              | 128 |
| 5.5    | Calibration of actual output of BMU 1 - 4.....                                                     | 129 |
|        | <i>Space heating OEM</i> .....                                                                     | 130 |
| 5.6    | Gain factor for room temperature influence (KORR) .....                                            | 130 |
| 5.7    | Constant for quick setback (KON).....                                                              | 131 |
| 5.8    | Boost of room temperature setpoint .....                                                           | 132 |
| 5.9    | Frost protection for the plant .....                                                               | 133 |
| 5.10   | Overtemperature protection .....                                                                   | 134 |
| 5.11   | Heat gains .....                                                                                   | 136 |
| 5.12   | Adaptation sensitivity 1.....                                                                      | 137 |
| 5.13   | Adaptation sensitivity 2.....                                                                      | 138 |
|        | <i>D.h.w. values OEM</i> .....                                                                     | 139 |
| 5.14   | Maximum nominal setpoint of d.h.w. temperature .....                                               | 139 |
| 5.15   | Switching differential of d.h.w. temperature.....                                                  | 140 |
| 5.16   | Legionella function .....                                                                          | 142 |
| 5.17   | Setpoint of legionella function .....                                                              | 142 |
| 5.18   | Protection against discharging of d.h.w.....                                                       | 143 |
|        | <i>Cascade settings OEM</i> .....                                                                  | 144 |
| 5.19   | Cascade management strategy .....                                                                  | 144 |
| 5.19.1 | Type of lead boiler operation .....                                                                | 145 |
| 5.19.2 | Running time strategies.....                                                                       | 146 |
| 5.20   | Minimum limit of output range (Pmin).....                                                          | 148 |
| 5.21   | Maximum limit of output range (Pmax).....                                                          | 149 |
| 5.22   | Mandatory time on the basic stage.....                                                             | 150 |
| 5.23   | Minimum temperature differential at the pressureless header.....                                   | 151 |

|       |                                                          |     |
|-------|----------------------------------------------------------|-----|
|       | <i>Configuration of plant</i> .....                      | 152 |
| 5.24  | Continuous display.....                                  | 152 |
|       | <i>General values</i> .....                              | 153 |
| 5.25  | Software version .....                                   | 153 |
| 5.26  | Number of device operating hours .....                   | 153 |
| 6     | Functions with no settings.....                          | 154 |
| 6.1   | Chimney sweep .....                                      | 154 |
| 6.2   | Generation of boiler temperature setpoint.....           | 155 |
| 6.3   | Automatic 24-hour heating limit.....                     | 156 |
| 6.3.1 | Without room temperature influence .....                 | 156 |
| 6.3.2 | With room temperature influence .....                    | 158 |
| 6.4   | Quick setback with a room temperature sensor .....       | 159 |
| 6.5   | D.h.w. push.....                                         | 160 |
| 6.6   | Pump kick .....                                          | 161 |
| 6.7   | Protection against discharging after d.h.w. heating..... | 161 |
| 6.8   | Overview of pump operation .....                         | 162 |
| 6.9   | Frost protection.....                                    | 163 |
| 6.9.1 | For the boiler.....                                      | 163 |
| 6.9.2 | For the d.h.w. ....                                      | 163 |
| 7     | Application examples .....                               | 164 |
| 7.1   | Plant types RVA47.320 - no. 27.....                      | 165 |
| 7.2   | Plant types RVA47.320 - no. 28.....                      | 166 |
| 7.3   | Plant types RVA47.320 - no. 29.....                      | 167 |
| 7.4   | Plant types RVA47.320 - no. 30.....                      | 168 |
| 7.5   | Plant types RVA47.320 - no. 31.....                      | 169 |
| 7.6   | Plant types RVA47.320 - no. 32.....                      | 170 |
| 7.7   | Plant types RVA47.320 - no. 33.....                      | 171 |
| 7.8   | Plant types RVA47.320 - no. 34.....                      | 172 |
| 7.9   | Plant types RVA47.320 - no. 35.....                      | 173 |
| 7.10  | Plant types RVA47.320 - no. 36.....                      | 174 |
| 7.11  | Plant types RVA47.320 - no. 65.....                      | 175 |
| 7.12  | Plant types RVA47.320 - no. 66.....                      | 176 |
| 7.13  | Plant types RVA47.320 - no. 67.....                      | 177 |
| 7.14  | Legend.....                                              | 178 |
| 8     | Dimensions .....                                         | 179 |
| 9     | Technical data.....                                      | 180 |

If you want to find a specific keyword, please refer to the “Index” at the end of this documentation.

# 1 Summary

## 1.1 Brief description

---

ALBATROS™- RVA47.320 (B-series) is designed for use as a single-boiler controller or cascade controller with up to four heat sources.

It is designed for integration in heat generating equipment / plants with

- a modulating gas burner
- a Boiler Management Unit (BMU)
- d.h.w. heating with charging pump (via RVA47) or changeover valve (via BMU)
- a primary or heating circuit pump

Heating circuit control uses weather compensation while d.h.w. heating operates depending on the storage tank temperature and the time program.

When employed in an interconnected system with additional controllers type RVA47.320 (B-series), it is possible to operate modulating cascades with up to 16 heat sources.

When employed in an interconnected system along with the ALBATROS™ controller RVA43.222 (C-series), it is possible to operate mixed cascades (modulating / multi-stage) with up to 16 heat sources.

### → Important

When used in connection with gas-fired heating boilers, the availability of a BMU is mandatory. Landis & Staefa offers two different types of BMUs:

- L&S-Boiler Management Unit LGM11.34, refer to data sheet N7629E
- L&S-Boiler Management Unit LGM11.44, refer to data sheet N7618E

It is also possible to use BMUs of other manufacture if they are appropriately equipped. If you intend to use a non-Landis & Staefa burner control in connection with the RVA47.320, please contact your nearest Landis & Staefa representative.

### Use in extensive systems

---

The range of products comprises several units that complement one another in terms of application and scope of functions. The controllers have communication capability and can be combined to form heating systems that include up to 40 controllers.

For more detailed information about the generation of LPB systems, refer to „Local Process Bus (LPB), Basic Documentation, System Engineering“, document no. CE1P2370E.

## 1.2 Features

---

### Heat generation

- Cascading with up to four modulating heat sources and one controller
- Cascading with up to 16 modulating heat sources and additional RVA47.320 (from B-series)
- Generation of mixed cascades (modulating / multi-stage) with up to 16 heat sources and additional RVA47.320 (from B-series) and the RVA43.222 (from C-series)
- Selectable boiler sequence and boiler strategy
- Weather-compensated heating circuit control with or without room temperature influence
- Cascade flow temperature control depending on the heat demand signal from the heating circuits connected to the system or from controllers outside the system (via input H1)
- Cascade flow temperature control depending on the temperature demand signal (DC 0...10 V, input H1)
- Adjustable maximum limitation of temperature demand signals delivered to the heating boiler
- Performance-related switching on / off of boilers, very accurate flow temperatures
- Supervision of operating conditions at the pressureless header, low return temperatures
- Heating circuit control with a pump heating circuit
- Remote operation via a digital room unit
- Quick setback and boost heating
- Automatic 24-hour heating limit
- Automatic summer / winter changeover
- The building's thermal dynamics are taken into consideration
- Automatic adjustment of the heating curve to the type of building construction and the heat demand (provided a room unit is connected)
- Overload detection (shifting priority)
- Manual operation

### Protection for the plant

- Protection against boiler overtemperatures (pump overrun)
- Protective boiler startup (acting on the mixing valve)
- Minimum limitation of the boiler return temperature (acting on the mixing valve)
- Adjustable minimum and maximum limitation of the boiler temperature (boiler flow temperature)
- Frost protection for the building, the plant and the boiler
- Frost protection for the d.h.w. storage tank connected directly to the controller
- Pump protection through periodic pump kick
- Overtemperature protection for the pump heating circuit

---

**Operation**

- Temperature adjustment with the setpoint knob
- 7-day or 24-hour program for the heating circuit and d.h.w. heating
- Automatic button for efficient operation throughout the year
- D.h.w. button
- Manual operation at the touch of a button
- Output and input tests to aid commissioning and functional checks
- Straightforward selection of operating mode via buttons
- Change of operating mode via a remote switch (via the H1-contact)
- Heat generation lock or minimum demand for temperature with the remote switch (via contact H1)
- Service connection facility for local parameter settings and data logging

---

**D.h.w.**

- D.h.w. heating with charging pump or via BMU with changeover valve
- D.h.w. control with temperature sensor or control thermostat
- Selectable priority for d.h.w. heating
- Selectable d.h.w. heating program
- Adjustable boost of the d.h.w. charging temperature
- Reduced setpoint of d.h.w. temperature
- Discharging protection for d.h.w.
- Automatic d.h.w. push
- Legionella function

---

**Use in extensive systems**

- Communication via Local Process Bus (LPB)
- Communicating via point-to-point interface (PPS)
- Controllers of other manufacture can deliver their heat demand signal by closing contact H1
- Controllers of other manufacture can deliver their analog heat demand by using DC 0...10 V signals
- Input for cascade flow temperature sensor
- Input for cascade return temperature sensor
- Integrity of system architecture with all RVA... controllers
- Can be extended to include 40 heating circuits (with central bus power supply)
- Optional remote supervision
- Fault status signals (own faults, faults of LPB devices, faults of PPS devices)

---

**Logging**

- Logging the individual BMU operating hours
- Logging the device operating hours

## 1.3 Range of products

The following units and accessories are designed for use with the ALBATROS range:

|                                        | <i>Type of unit</i> | <i>Description</i>                                                                    | <i>Documentation no.</i> |
|----------------------------------------|---------------------|---------------------------------------------------------------------------------------|--------------------------|
| Controllers                            | RVA47.320           | Cascade controller for modulating gas-fired heating boilers (from B-series)           | CE1P2379E                |
|                                        | RVA43.222           | Boiler and heating circuit controller (from C-series)                                 | CE1P2390E                |
|                                        | RVA46.531           | Heating circuit controller                                                            | CE1P2372E                |
|                                        | RVA66.540           | Heating circuit or primary controller                                                 | CE1P2378E*               |
| Burner controls                        | LGM11.34            | Landis & Staefa BMU for heating circuit and d.h.w. control                            |                          |
|                                        | LGM11.44            | Landis & Staefa BMU for heating circuit and d.h.w. control                            |                          |
|                                        | .....               | Different types of non-Landis & Staefa burner controls for d.h.w. control (e.g. MCBA) |                          |
|                                        | OCI12               | Communication interface RVA-LGM11                                                     |                          |
|                                        | RMCI                | Communication interface RVA-MCBA                                                      |                          |
| Room units                             | QAA10               | Digital room temperature sensor                                                       |                          |
|                                        | QAA70               | Digital, multi-functional room unit                                                   |                          |
|                                        | QAA50               | Digital room unit                                                                     |                          |
| Sensor                                 | QAC31               | Outside sensor NTC 600                                                                |                          |
|                                        | QAC21               | Outside sensor Ni 1000                                                                |                          |
|                                        | QAZ21               | Immersion temperature sensor Ni 1000 complete with cable                              |                          |
|                                        | QAD21               | Clamp-on temperature sensor Ni 1000                                                   |                          |
| Screw type terminal strips<br>(Rast 5) | AGP2S.02M           | LPB (two poles)                                                                       | violet                   |
|                                        | AGP2S.02G           | Room unit (two poles)                                                                 | blue                     |
|                                        | AGP2S.06A           | Sensor (six poles)                                                                    | white                    |
|                                        | AGP3S.02D           | Mains (double pole)                                                                   | black                    |
|                                        | AGP3S.03B           | Pump (three poles)                                                                    | brown                    |

## 1.4 Field of use

---

|                           |                                                                                                                                                                                                                                                                                                                                                                                                                                                                                                                                                                                                                   |
|---------------------------|-------------------------------------------------------------------------------------------------------------------------------------------------------------------------------------------------------------------------------------------------------------------------------------------------------------------------------------------------------------------------------------------------------------------------------------------------------------------------------------------------------------------------------------------------------------------------------------------------------------------|
| Target market             | <ul style="list-style-type: none"><li>• OEMs</li><li>• Manufacturers of modulating gas-fired appliances with BMUs.</li></ul>                                                                                                                                                                                                                                                                                                                                                                                                                                                                                      |
| Types of buildings        | <ul style="list-style-type: none"><li>• Residential and non-residential buildings with own heating and d.h.w. heating facility</li><li>• Residential and non-residential buildings with a central heat generating plant</li></ul>                                                                                                                                                                                                                                                                                                                                                                                 |
| Types of heating systems  | <ul style="list-style-type: none"><li>• Standard heating systems, such as:<br/>Standard heating systems, such as radiator, convector, underfloor and ceiling heating systems, and radiant panels</li><li>• With or without d.h.w. heating</li></ul>                                                                                                                                                                                                                                                                                                                                                               |
| Heat generating equipment | <ul style="list-style-type: none"><li>• Gas-fired heating boilers with modulating burners.</li><li>• Parallel cascading with lead / lag boiler changeover or fixed priority for up to four modulating gas-fired boilers (of identical or different capacities) with only one controller</li><li>• Parallel cascading with up to 16 modulating gas-fired boilers (of identical or different capacities) with additional RVA47.320 (from B-series)</li><li>• Mixed cascades with up to 16 modulating and multi-stage heat sources with additional RVA47.320 (from B-series) and RVA43.222 (from C-series)</li></ul> |

## 1.5 Product liability

---

- The products may only be used in building services plant and applications as described above
- When using the products, all requirements specified under "Technical data" and "Handling" must be satisfied
- When using the products in a system, all requirements contained in the documentation "Local Process Bus (LPB), Basic Documentation, System Engineering" (document no. CE1P2370E) must be satisfied
- The local regulations for installation must be complied with.

## 2 Handling

### 2.1 Installation

#### 2.1.1 Mounting location

---

- Boiler control panel
- In the control panel front

#### 2.1.2 Regulations for installation

---

- A clearance of at least 10 mm must be provided on all sides of the controller, enabling the unit to emit the amount of heat produced during its operation. The space should not be accessible and no objects should be placed there.
- The controller is designed for mounting in a boiler control panel. Power to the controller may be supplied only after it is completely fitted in the cutout. If this is not observed, there is a risk of electric shock near the terminals and through the cooling slots.
- If the controller shall be mounted directly on the wall, a housing must be used to provide protection against electric shock hazard. The housing must have a sufficient number of cooling slots at the bottom and the top, allowing the controller to emit the heat it produces.
- The controller has been designed based on the guidelines of safety class 2 and must therefore be mounted in compliance with these regulations.
- The controller may not be exposed to dripping water.
- Permissible ambient temperature: 0...50 °C

#### 2.1.3 Mounting procedure

---

First step

*Description*

*Diagram*

---

- Turn off power supply
- Pull the prefabricated cables through the cutout
- Plug the connectors into the respective sockets at the rear of the controller

➔ *Note:*  
*The connectors are coded to make certain they cannot be mixed up.*

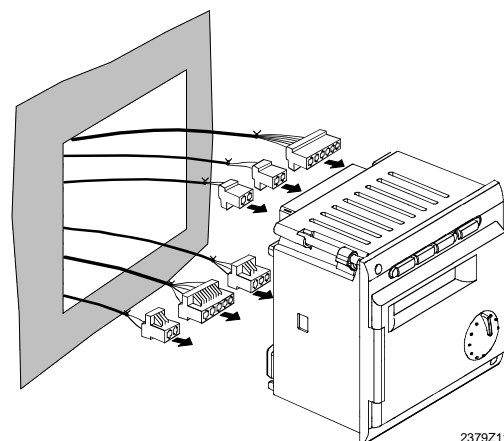

2379Z11

## Second step

- Check to ensure the fixing levers are turned inward
- Check to make certain there is sufficient space between the front panel and the fixing levers

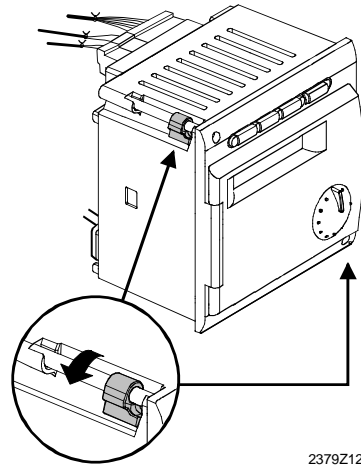

2379Z12

## Third step

- Slide the controller into the panel cutout without applying any force
- ➔ **Note:**  
*Do not use any tools when inserting the unit into the cutout. If it does not fit, check the size of the cutout and the housing.*

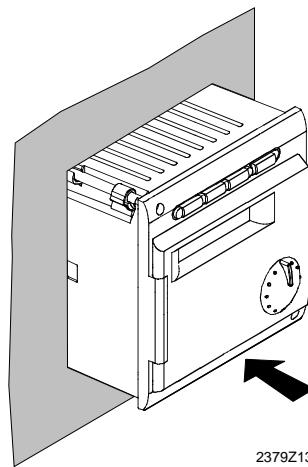

2379Z13

## Fourth step

- Secure the fixing levers by tightening the two screws on the front of the controller.
- ➔ **Note:**  
*Tighten the screws only slightly. When tightening the screws, the fixing levers automatically assume their correct position.*

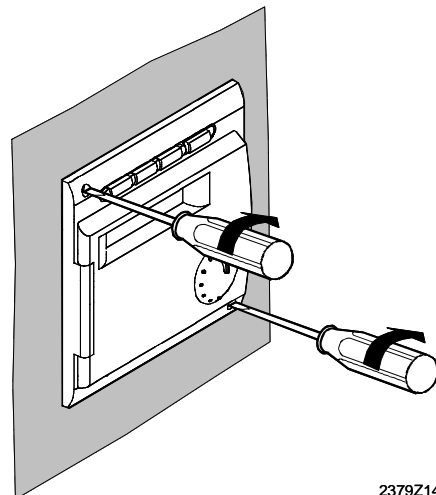

2379Z14

## 2.1.4 Required cutout

### Dimensions of cutout

The controller's mounting dimensions are 91 x 91 mm.

Due to the dimensions of the front, however, the standard spacing is 96 mm.

The mechanical mounting facility allows the controller to be fitted in front panels having a thickness of 2 to 10 mm.

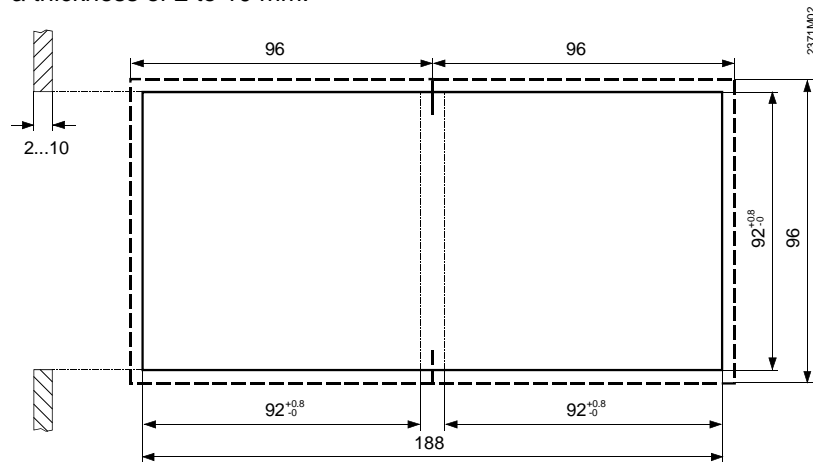

### Use of several controllers

The mechanical mounting facility makes it possible to arrange several controllers in a row in one cutout. In that case, it is merely necessary to have a wider panel cutout.

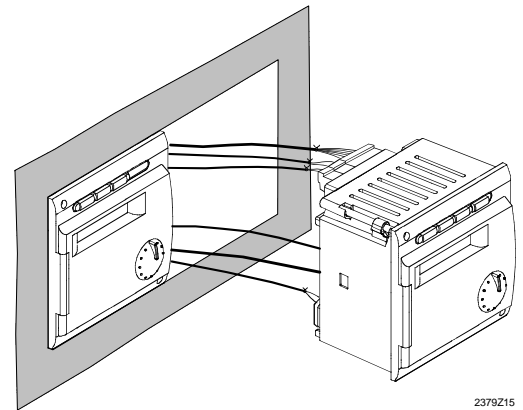

2379Z15

## 2.1.5 Orientation

To avoid overtemperatures inside the controller, the inclination may be no more than 30° and there must be a clearance of at least 10 mm on all sides of the unit.

This allows the controller to emit the heat generated during operation.

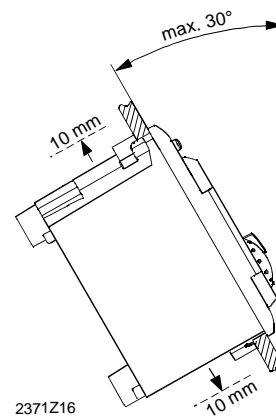

2371Z16

## 2.2 Electrical installation

### 2.2.1 Regulations for installation

- The connections for mains and low voltage are separated
- The wiring must be made in compliance with the requirements of safety class II.  
This means that sensor and mains cables may not be run in the same duct

### 2.2.2 Wiring

When using prefabricated cables with connectors, the electrical installation is very straightforward, owing to the coding.

#### Connection terminals

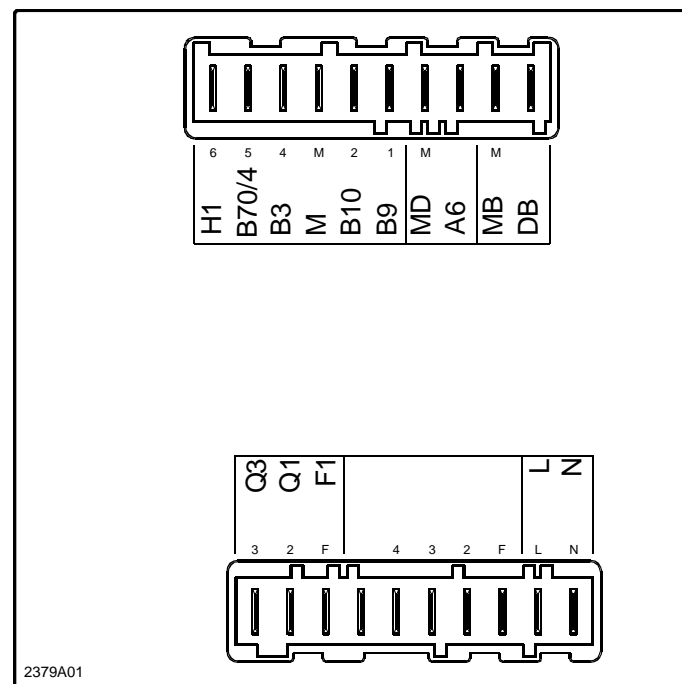

Rear of controller

**Low voltage side**

| <i>Terminal</i> | <i>Terminals</i>                                                                      | <i>Connector</i>   |
|-----------------|---------------------------------------------------------------------------------------|--------------------|
| H1              | Input H1                                                                              | AGP2S.06A (white)  |
| B70/B4          | Cascade return temperature sensor B70 or<br>buffer storage tank temperature sensor B4 |                    |
| B3              | D.h.w. temperature sensor or thermostat                                               |                    |
| M               | Ground sensor                                                                         |                    |
| B10             | Cascade flow temperature sensor<br>(common flow temperature sensor)                   |                    |
| B9              | Outside sensor                                                                        |                    |
| MD              | Ground PPS (room unit, BMU)                                                           | AGP2S.02G (blue)   |
| A6              | PPS (room unit, BMU)                                                                  |                    |
| MB              | Ground bus (LPB)                                                                      | AGP2S.02M (violet) |
| DB              | Data bus (LPB)                                                                        |                    |

**Mains voltage side**

| <i>Terminal</i> | <i>Terminals</i>                 | <i>Connector</i>  |
|-----------------|----------------------------------|-------------------|
| Q3              | D.h.w. charging pump             | AGP3S.03B (brown) |
| Q1              | Heating circuit or primary pump: |                   |
| F1              | Phase Q1 / Q3                    |                   |
| -               | Not used                         | -                 |
| -               | Not used                         |                   |
| -               | Not used                         |                   |
| -               | Not used                         |                   |
| -               | Not used                         |                   |
| L               | Live AC 230 V (mains connection) | AGP3S.02D (black) |
| N               | Neutral (mains connection)       |                   |

## 2.3 Commissioning

### Prerequisites









To commission the controller:

1. Make certain that mounting and electrical installation are in compliance with the relevant requirements.
2. Make all plant-specific settings as described in section "Parameter settings".
3. Reset the attenuated outside temperature (operating line 19).
4. Make the functional checks.

### 2.3.1 Functional checks

To facilitate commissioning and fault tracing, the controller allows output and input tests to be made. This allows to test the outputs and inputs.

### Output test (relays)





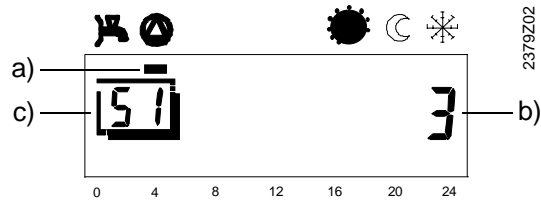





|   | Buttons                                                                                                                                                                        | Explanation                                                                                                                                                                                                                                                                                                                                                                                                                                                                                                                                                                                                                      | Line                                                                                                                                                                                                                                                                                                                 |                                                                                       |
|---|--------------------------------------------------------------------------------------------------------------------------------------------------------------------------------|----------------------------------------------------------------------------------------------------------------------------------------------------------------------------------------------------------------------------------------------------------------------------------------------------------------------------------------------------------------------------------------------------------------------------------------------------------------------------------------------------------------------------------------------------------------------------------------------------------------------------------|----------------------------------------------------------------------------------------------------------------------------------------------------------------------------------------------------------------------------------------------------------------------------------------------------------------------|---------------------------------------------------------------------------------------|
| 1 |                                                                                               | Press one of the line selection buttons.<br><i>This will take you first to the programming mode "End-user".</i>                                                                                                                                                                                                                                                                                                                                                                                                                                                                                                                  |                                                                                                                                                                                                                                   |                                                                                       |
| 2 |                                                                                               | Press both line selection buttons for at least 3 seconds.<br><br>This will take you to the programming and, at the same time, to the output test (relay test).                                                                                                                                                                                                                                                                                                                                                                                                                                                                   |                                                                                                                                                                                                                                   |                                                                                       |
| 3 |                                                                                             | Press the plus or minus button repeatedly, which will take you one test step further:<br><br><div style="display: flex; align-items: center;"> <div style="border: 1px solid gray; padding: 5px; margin-right: 10px;">Test step 0</div> <div style="margin-right: 10px;">↕</div> <div style="border: 1px solid gray; padding: 5px; margin-right: 10px;">Test step 1</div> <div style="margin-right: 10px;">↕</div> <div style="border: 1px solid gray; padding: 5px; margin-right: 10px;">Test step 2</div> <div style="margin-right: 10px;">↕</div> <div style="border: 1px solid gray; padding: 5px;">Test step 3</div> </div> | <div style="margin-bottom: 10px;">All outputs are switched according to actual control operation</div> <div style="margin-bottom: 10px;">All outputs are deactivated</div> <div style="margin-bottom: 10px;">D.h.w. charging pump (Q3) is activated</div> <div>Heating circuit or primary pump activated (Q1).</div> |  |
| 4 | <br><br> | You leave the programming line "Output test" by pressing either one of the line selection buttons,<br><br>or one of the operating mode buttons<br><br><b>→ Note:</b><br><i>If no button is pressed for about 8 minutes, the controller will automatically return to the operating mode selected last.</i>                                                                                                                                                                                                                                                                                                                        | Continuous display                                                                                                                                                                                                                                                                                                   |                                                                                       |

## Display



- a) The bar below the symbol indicates the output activated
- b) The number indicates the current test step
- c) The framed number indicates the selected setting line.

**Input test  
(sensors)**

|   | Buttons                                                                                                                                                                        | Explanation                                                                                                                                                                                                                                                                                                                                                                                                                                                                                                                                                                                                                                                                                                                                                                                                                                                                                                              | Line                                                                                                                                                                                                                                                                                                                                                                                      |                                                                                     |
|---|--------------------------------------------------------------------------------------------------------------------------------------------------------------------------------|--------------------------------------------------------------------------------------------------------------------------------------------------------------------------------------------------------------------------------------------------------------------------------------------------------------------------------------------------------------------------------------------------------------------------------------------------------------------------------------------------------------------------------------------------------------------------------------------------------------------------------------------------------------------------------------------------------------------------------------------------------------------------------------------------------------------------------------------------------------------------------------------------------------------------|-------------------------------------------------------------------------------------------------------------------------------------------------------------------------------------------------------------------------------------------------------------------------------------------------------------------------------------------------------------------------------------------|-------------------------------------------------------------------------------------|
| 1 |                                                                                               | Press one of the line selection buttons.<br><i>This will take you first to the programming mode "End-user".</i>                                                                                                                                                                                                                                                                                                                                                                                                                                                                                                                                                                                                                                                                                                                                                                                                          |                                                                                                                                                                                                                                                                                                        |                                                                                     |
| 2 |                                                                                               | Press both line selection buttons for at least 3 seconds.<br><i>This will take you to the programming level "Heating engineer".</i>                                                                                                                                                                                                                                                                                                                                                                                                                                                                                                                                                                                                                                                                                                                                                                                      |                                                                                                                                                                                                                                                                                                        |                                                                                     |
| 3 |                                                                                               | Press line selection button "Up" until you reach line 52.<br><br>This will take you to the input test.                                                                                                                                                                                                                                                                                                                                                                                                                                                                                                                                                                                                                                                                                                                                                                                                                   |                                                                                                                                                                                                                                                                                                        |                                                                                     |
| 4 |                                                                                               | Press the plus or minus button repeatedly, which will take you one test step further:<br><br><div style="display: flex; align-items: center;"> <div style="border: 1px solid gray; padding: 5px; margin-right: 10px;">Test step 0</div> <div style="margin-right: 10px;">↑</div> <div style="border: 1px solid gray; padding: 5px; margin-right: 10px;">Test step 1</div> <div style="margin-right: 10px;">↑</div> <div style="border: 1px solid gray; padding: 5px; margin-right: 10px;">Test step 2</div> <div style="margin-right: 10px;">↑</div> <div style="border: 1px solid gray; padding: 5px; margin-right: 10px;">Test step 3</div> <div style="margin-right: 10px;">↑</div> <div style="border: 1px solid gray; padding: 5px; margin-right: 10px;">Test step 4</div> <div style="margin-right: 10px;">↑</div> <div style="border: 1px solid gray; padding: 5px; margin-right: 10px;">Test step 5</div> </div> | <p>Display of the function selected on line 97 (B70/B4) [°C].</p> <p>Display of d.h.w. temperature (B3).</p> <p>Display of the cascade temperature (B10).</p> <p>Display of the actual outside temperature (B9)</p> <p>Display of room temperature acquired with room unit connected to A6</p> <p>Display input H1 according to the function selected on line 170 [°C, - - -, o o o].</p> |  |
| 5 | <br><br> | <p>You leave the programming line "Input test" by pressing either one of the line selection buttons,</p> <p>or one of the operating mode or function buttons</p> <p>➔ Note:<br/><i>If no button is pressed for about 8 minutes, the controller will automatically return to the operating mode selected last.</i></p>                                                                                                                                                                                                                                                                                                                                                                                                                                                                                                                                                                                                    | Continuous display                                                                                                                                                                                                                                                                                                                                                                        |                                                                                     |

The selected sensor values are updated within a maximum of 5 seconds. If no sensor is present, the connecting line interrupted, or the contact open, the display shows "---". In the event of a short-circuit, or if the contact is closed, the LCD displays "ooo".

## Display

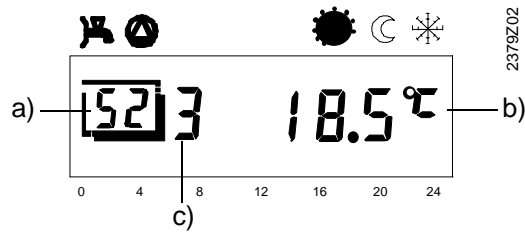







- a) The framed number indicates the selected setting line.
- b) Displayed value of the temperature measured
- c) The number indicates the selected test step.

## 2.4 Parameter settings for the end-user

### Description

The following settings can be made to meet the individual needs of the enduser.

### Setting

|   | <i>Buttons</i>                                                                     | <i>Explanation</i>                                                                                                                                                                                                                                      | <i>Line</i>                                                                         |
|---|------------------------------------------------------------------------------------|---------------------------------------------------------------------------------------------------------------------------------------------------------------------------------------------------------------------------------------------------------|-------------------------------------------------------------------------------------|
| 1 |   | Press one of the line selection buttons.<br><i>This will take you directly to the programming mode "End-user".</i>                                                                                                                                      |  |
| 2 |   | Press the line selection buttons to select the required line.<br><i>The parameter list on the next two pages contains all available lines.</i>                                                                                                          |  |
| 3 |   | Press the plus or minus button to set the required value.<br>The setting will be stored as soon as you leave the programming mode or change to another line.<br><i>The parameter list on the next two pages contains all settings that can be made.</i> |                                                                                     |
| 4 |  | By pressing any of the operating mode buttons, you leave the programming mode "Enduser".<br>→ Note:<br><i>If no button is pressed for about 8 minutes, the controller will automatically return to the operating mode selected last.</i>                | Continuous display                                                                  |

## 2.4.1 Overview of end-user parameters









| Line                                           | Function                                                                                                                                                      | Range                | Unit    | Resolution | Factory setting |
|------------------------------------------------|---------------------------------------------------------------------------------------------------------------------------------------------------------------|----------------------|---------|------------|-----------------|
| <b>Setting the clock</b>                       |                                                                                                                                                               |                      |         |            |                 |
| 1                                              | Time of day                                                                                                                                                   | 0...23:59            | h / min | 1 min      | -               |
| 2                                              | Weekday                                                                                                                                                       | 1...7                | day     | 1 day      | -               |
| <b>Time switch program for heating circuit</b> |                                                                                                                                                               |                      |         |            |                 |
| 5                                              | Weekday-preselection heating circuit<br>1-7 7-day block<br>1...7 Individual days                                                                              | 1-7 / 1...7          | day     | 1 day      | -               |
| 6                                              | Switch-on time 1. period heating circuit                                                                                                                      | 00:00...23:59        | h / min | 10 min     | 06:00           |
| 7                                              | Switch-off time 1. period heating circuit                                                                                                                     | 00:00...23:59        | h / min | 10 min     | 22:00           |
| 8                                              | Switch-on time 2. period heating circuit                                                                                                                      | 00:00...23:59        | h / min | 10 min     | - :- -          |
| 9                                              | Switch-off time 2. period heating circuit                                                                                                                     | 00:00...23:59        | h / min | 10 min     | - :- -          |
| 10                                             | Switch-on time 3. period heating circuit                                                                                                                      | 00:00...23:59        | h / min | 10 min     | - :- -          |
| 11                                             | Switch-off time 3. period heating circuit                                                                                                                     | 00:00...23:59        | h / min | 10 min     | - :- -          |
| <b>D.h.w. values</b>                           |                                                                                                                                                               |                      |         |            |                 |
| 13                                             | Nominal setpoint of d.h.w. temperature (TBWw)<br>TBWR Line 120<br>TBWmax Line 40 (OEM)                                                                        | TBWR...TBWmax        | °C      | 1          | 55              |
| <b>Heating circuit values</b>                  |                                                                                                                                                               |                      |         |            |                 |
| 14                                             | Reduced setpoint of room temperature (TRRw)<br>TRF Line 15<br>TRN Setpoint knob                                                                               | TRF...TRN            | °C      | 0.5        | 16              |
| 15                                             | Frost protection setpoint of room temperature (TRFw)<br>TRR Line 14                                                                                           | 4...TRR              | °C      | 0.5        | 10              |
| 16                                             | Summer / winter changeover temperature                                                                                                                        | 8...30               | °C      | 0.5        | 17              |
| 17                                             | Slope of heating curve<br>-:- Inactive<br>2,5...40 Active                                                                                                     | -:- / 2.5...40       | -       | 0.5        | 15              |
| <b>Actual values</b>                           |                                                                                                                                                               |                      |         |            |                 |
| 18                                             | Actual value of room temperature (TRx)                                                                                                                        | 0...50               | °C      | 0.5        | -               |
| 19                                             | Actual value of outside temperature (TAX)<br>To set the attenuated outside temperature to Tax, press the plus and minus buttons simultaneously for 3 seconds. | -50...+50            | °C      | 0.5        | -               |
| <b>Maintenance</b>                             |                                                                                                                                                               |                      |         |            |                 |
| 23                                             | Standard time program for heating circuit and d.h.w.<br>To activate, press the plus and minus buttons simultaneously for 3 seconds                            | 0/1                  | -       | 1          | 0               |
| <b>Time switch program for d.h.w. heating</b>  |                                                                                                                                                               |                      |         |            |                 |
| 29                                             | Weekday-preselection d.h.w.<br>1-7 7-day block<br>1...7 Individual days                                                                                       | 1-7 / 1...7          | day     | 1 day      | -               |
| 30                                             | Switch-on time 1. 3 <sup>rd</sup> period d.h.w.                                                                                                               | 00:00...23:59        | h / min | 10 min     | 06:00           |
| 31                                             | Switch-off time 1. 3 <sup>rd</sup> period d.h.w.                                                                                                              | 00:00...23:59        | h / min | 10 min     | 22:00           |
| 32                                             | Switch-on time 2. 3 <sup>rd</sup> period d.h.w.                                                                                                               | 00:00...23:59        | h / min | 10 min     | - :- -          |
| 33                                             | Switch-off time 2. 3 <sup>rd</sup> period d.h.w.                                                                                                              | 00:00...23:59        | h / min | 10 min     | - :- -          |
| 34                                             | Switch-on time 3. 3 <sup>rd</sup> period d.h.w.                                                                                                               | 00:00...23:59        | h / min | 10 min     | - :- -          |
| 35                                             | Switch-off time 3. 3 <sup>rd</sup> period d.h.w.                                                                                                              | 00:00...23:59        | h / min | 10 min     | - :- -          |
| <b>Service</b>                                 |                                                                                                                                                               |                      |         |            |                 |
| 49                                             | Indication of BMU error code<br>1...4 = BMU number, 1...255 = error code                                                                                      | 1...4 / 0...255      | -       | 1          | -               |
| 50                                             | Indication of faults                                                                                                                                          | 0..255 / 00.01-14.16 | -       | 1          | -               |

## 2.5 Parameter settings for the heating engineer

### Description

Configuration and parameter settings to be made by the heating engineer.

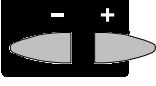
### Setting

|   | <i>Buttons</i>                                                                      | <i>Explanation</i>                                                                                                                                                                                                                                              | <i>Line</i>                                                                         |
|---|-------------------------------------------------------------------------------------|-----------------------------------------------------------------------------------------------------------------------------------------------------------------------------------------------------------------------------------------------------------------|-------------------------------------------------------------------------------------|
| 1 |    | Press one of the line selection buttons.<br><i>This will take you first to the programming mode "End-user".</i>                                                                                                                                                 |  |
| 2 |    | Press both line selection buttons for at least 3 seconds.<br><br><i>This will take you to the programming level "End-user".</i>                                                                                                                                 |  |
| 3 |    | Press the line selection buttons to select the required line.<br><br><i>The parameter list on the next two pages contains all available lines.</i>                                                                                                              |  |
| 4 |    | Press the plus or minus button to set the required value.<br><br>The setting will be stored as soon as you leave the programming mode or change to another line.<br><br><i>The parameter list on the next two pages contains all settings that can be made.</i> |                                                                                     |
| 5 |  | You leave the programming level "Heating engineer" by pressing one of the operating mode buttons.<br><br>➔ Note:<br><i>If no button is pressed for about 8 minutes, the controller will automatically return to the operating mode selected last.</i>           | Continuous display                                                                  |

## 2.5.1 Overview of heating engineer parameters

| Line                          | Function                                                                                                                                                                                                                                                                           | Range                    | Unit | Resolution | Factory setting |
|-------------------------------|------------------------------------------------------------------------------------------------------------------------------------------------------------------------------------------------------------------------------------------------------------------------------------|--------------------------|------|------------|-----------------|
| <b>Service values</b>         |                                                                                                                                                                                                                                                                                    |                          |      |            |                 |
| 51                            | Output test (realy test)<br>0 Control mode according to the operational status<br>1 All outputs are deactivated<br>2 D.h.w. charging pump ON Q3<br>3 Heating circuit / primary pump ON Q1                                                                                          | 0...3                    | -    | 1          | 0               |
| 52                            | Input test (sensor test)<br>0 Cascade return temperature sensor B70/B4<br>or buffer storage tank temperature sensor<br>1 D.h.w. temperature sensor B3<br>2 Cascade flow temperature sensor B10<br>3 Outside sensor B9<br>4 Room temperature sensor (room unit) A6<br>5 Input H1 H1 | 0...5                    | -    | 1          | 0               |
| 53                            | Display of plant type                                                                                                                                                                                                                                                              | 27...36 / 65...67        | -    | 1          | -               |
| 54                            | Display of PPS communication<br>- - - No communication<br>1...12 PPS device address<br>0...255 identification code                                                                                                                                                                 | --- / 1..12 / 0..255     | -    | 1          | -               |
| <b>Actual values</b>          |                                                                                                                                                                                                                                                                                    |                          |      |            |                 |
| 55                            | Actual value of boiler temperature of BMUs (TKx)<br>1...4 = BMU number, 0...140 = actual value of boiler temperature<br>(interrogate with + / - buttons)                                                                                                                           | 1...4 / 0...140          | °C   | 1          | -               |
| 56                            | Actual value of cascade flow temperature<br>Input B10                                                                                                                                                                                                                              | 0...140                  | °C   | 1          | -               |
| 57                            | Actual value of cascade return temperature<br>Input B70                                                                                                                                                                                                                            | 0...140                  | °C   | 1          | -               |
| 58                            | Actual value of buffer storage tank temperature<br>Input B4                                                                                                                                                                                                                        | 0...140                  | °C   | 1          | -               |
| 59                            | Actual value of d.h.w. temperature (TBWx)<br>(Input B3 or value from BMU)                                                                                                                                                                                                          | 0...140                  | °C   | 1          | -               |
| 60                            | Attenuated outside temperature (Taxged)                                                                                                                                                                                                                                            | -50.0...+50.0            | °C   | 0.5        | -               |
| 61                            | Composite outside temperature (Taxgem)                                                                                                                                                                                                                                             | -50.0...+50.0            | °C   | 0.5        | -               |
| 62                            | Outside temperature source<br>--.-- No signal<br>00.01 Segment / device address                                                                                                                                                                                                    | --.-- /<br>00.01...14.16 | -    | -          | -               |
| <b>Setpoints</b>              |                                                                                                                                                                                                                                                                                    |                          |      |            |                 |
| 65                            | Setpoint of boiler temperature of BMUs (TKx)<br>1...4 = BMU number, 0...140 = setpoint of boiler temperature<br>(interrogate with + / - buttons)                                                                                                                                   | 1...4 / 0...140          | °C   | 1          | -               |
| 66                            | Setpoint of cascade flow temperature                                                                                                                                                                                                                                               | 0...140                  | °C   | 1          | -               |
| 69                            | Setpoint of d.h.w. temperature (TBWw)                                                                                                                                                                                                                                              | 0...140                  | °C   | 1          | -               |
| 70                            | Nominal room temperature setpoint<br>Nominal setpoint plus readjustment made on the room unit                                                                                                                                                                                      | 0.0...35.0               | °C   | 0.5        | -               |
| 71                            | Setpoint of room temperature (TRRw)                                                                                                                                                                                                                                                | 0.0...35.0               | °C   | 0,5        | -               |
| 72                            | Flow temperature setpoint (TVw)                                                                                                                                                                                                                                                    | 0...140                  | °C   | 1          | -               |
| <b>Heat generation values</b> |                                                                                                                                                                                                                                                                                    |                          |      |            |                 |
| 75                            | Display of the available cascade boilers<br>(--- = none)                                                                                                                                                                                                                           | --- / 00.1...16.3        | -    | 01.1       | -               |
| 76                            | Display of the lead boiler                                                                                                                                                                                                                                                         | --- / 00.1...16.3        | -    | 01.1       | -               |
| 77                            | Remaining number of operating hours for changeover<br>of boiler sequence<br>Only if a value is selected on line 130, otherwise the LCD displays ---                                                                                                                                | 0...990                  | h    | 1          | -               |
| 80                            | Hours run BMU 1                                                                                                                                                                                                                                                                    | 0...65535                | h    | 1          | 0               |
| 81                            | Hours run BMU 2                                                                                                                                                                                                                                                                    | 0...65535                | h    | 1          | 0               |
| 82                            | Hours run BMU 3                                                                                                                                                                                                                                                                    | 0...65535                | h    | 1          | 0               |

| Line                          | Function                                                                                                                                                                                             | Range                                    | Unit   | Resolution | Factory setting |
|-------------------------------|------------------------------------------------------------------------------------------------------------------------------------------------------------------------------------------------------|------------------------------------------|--------|------------|-----------------|
| 83                            | Hours run BMU 4                                                                                                                                                                                      | 0...65535                                | h      | 1          | 0               |
| 90                            | Minimum limitation of boiler temperature (TKmin)                                                                                                                                                     | TKmin <sub>OEM</sub> ...<br>TKmax (95°C) | °C     | 1          | 8               |
| 91                            | Nominal output BMU 1                                                                                                                                                                                 | 0...255                                  | kW     | 1          | 20              |
| 92                            | Nominal output BMU 2                                                                                                                                                                                 | 0...255                                  | kW     | 1          | 20              |
| 93                            | Nominal output BMU 3                                                                                                                                                                                 | 0...255                                  | kW     | 1          | 20              |
| 94                            | Nominal output BMU 4                                                                                                                                                                                 | 0...255                                  | kW     | 1          | 20              |
| <b>Configuration of plant</b> |                                                                                                                                                                                                      |                                          |        |            |                 |
| 95                            | Pump function output Q1<br>1 Heating circuit pump or no pump<br>2 Primary pump for HCs only<br>3 Primary pump for heating circuits and d.h.w. storage tank<br>4 D.h.w. circulating pump<br>5 Pump H1 | 1...5                                    | -      |            | 1               |
| 97                            | Use of sensor input B70/B4<br>1 Cascade return temperature (B70)<br>2 Buffer storage tank temperature sensor (B4)                                                                                    | 1...2                                    | -      | 1          | 1               |
| <b>Space heating</b>          |                                                                                                                                                                                                      |                                          |        |            |                 |
| 100                           | Parallel displacement of heating curve                                                                                                                                                               | -4,5...+4,5                              | K (°C) | 0.5        | 0,0             |
| 101                           | Gain factor for room temperature influence<br>0 Inactive<br>1 Active                                                                                                                                 | 0 / 1                                    | -      | 1          | 1               |
| 102                           | Switching differential of room temperature (SDR)<br>- - - Inactive<br>0,5...4,0 Active                                                                                                               | - - - / 0,5...4,0                        | K (°C) | 0.5        | - - -           |
| 103                           | Minimum limitation of flow temperature setpoint (TVmin)<br>TVmax Line 104                                                                                                                            | 8...TVmax                                | °C     | 1          | 8               |
| 104                           | Maximum limitation of flow temperature setpoint (TVmax)<br>TVmin Line 103                                                                                                                            | TVmin...95                               | °C     | 1          | 80              |
| 105                           | Type of building construction<br>0 Heavy<br>1 Light                                                                                                                                                  | 0 / 1                                    | -      | 1          | 1               |
| 106                           | Adaptation of heating curve<br>0 Inactive<br>1 Active                                                                                                                                                | 0 / 1                                    | -      | 1          | 1               |
| <b>D.h.w.</b>                 |                                                                                                                                                                                                      |                                          |        |            |                 |
| 120                           | Reduced setpoint of d.h.w. temperature (TBWw)<br>TBWw Line 13                                                                                                                                        | 8...TBWw                                 | °C     | 1          | 40              |
| 121                           | Release of d.h.w. heating<br>0 24 h/day<br>1 According to the heating circuit time switch programs with forward shift<br>2 According to d.h.w. time switch program (lines 29...35)                   | 0...2                                    | -      | 1          | 1               |
| 122                           | Switching program circulating pump<br>0 According to heating circuit time switch program<br>1 According to release of d.h.w. heating                                                                 | 0...1                                    | -      | 1          | 1               |
| 123                           | Assignment of d.h.w. heating<br>0 For local consumer only<br>1 For all consumers in the same segment<br>2 For all consumers in the system                                                            | 0...2                                    | -      | 1          | 2               |
| 124                           | D.h.w. charging<br>0 Once per day (forward shift 2.5 h)<br>1 Several times per day (forward shift 1h)                                                                                                | 0 / 1                                    | -      | 1          | 1               |
| 125                           | Type of d.h.w. demand<br>0 Sensor<br>1 Control thermostat                                                                                                                                            | 0 / 1                                    | -      | 1          | 0               |
| 126                           | Flow temperature boost for d.h.w.                                                                                                                                                                    | 0...30                                   | K      | 1          | 16              |











| <b>Line</b>             | <b>Function</b>                                                                                                                                                                                                                             | <b>Range</b>   | <b>Unit</b>  | <b>Resolution</b> | <b>Factory setting</b> |
|-------------------------|---------------------------------------------------------------------------------------------------------------------------------------------------------------------------------------------------------------------------------------------|----------------|--------------|-------------------|------------------------|
| 127                     | D.h.w. priority<br>0 MK + PK absolute<br>1 MK + PK shifting<br>2 None (parallel)<br>3 MK shifting, PK absolute                                                                                                                              | 0...3          | 1            | 1                 | 1                      |
| 129                     | Demand for heat with reduced setpoint of d.h.w.<br>0 No (application with buffer storage tank)<br>1 Yes                                                                                                                                     | 0 / 1          | -            | 1                 | 1                      |
| <b>Cascade settings</b> |                                                                                                                                                                                                                                             |                |              |                   |                        |
| 130                     | Changeover of boiler sequence in cascades<br>--- No automatic changeover (fixed boiler sequence)<br>10...990 Changeover according to the selected number of hours                                                                           | --- / 10...990 | - /<br>hours | 10                | 500                    |
| 131                     | Exclusion with autom. Changeover of boiler sequence<br>0 None<br>1 First boiler<br>2 Last boiler<br>3 First and last boiler                                                                                                                 | 0...3          | -            | 1                 | 0                      |
| 132                     | Lead boiler with the fixed sequence                                                                                                                                                                                                         | 00.1...16.3    | -            | 01.1              | -                      |
| 133                     | Switch-on delay lag boilers                                                                                                                                                                                                                 | 2...120        | min          | 1                 | 5                      |
| 134                     | Restart lock of BMUs                                                                                                                                                                                                                        | 0...1800       | s            | 10                | 300                    |
| <b>LPB / system</b>     |                                                                                                                                                                                                                                             |                |              |                   |                        |
| 140                     | LPB device address<br>0 Standalone<br>1...16 Device number                                                                                                                                                                                  | 0...16         | -            | 1                 | 1                      |
| 141                     | LPB segment address<br>0 Central segment (heat generation)<br>1...14 Segment (heat consumers)                                                                                                                                               | 0...14         | -            | 1                 | 0                      |
| 142                     | Bus power supply<br>0 Off (central bus power supply)<br>1 AUTOMATIC (controller - bus power supply)                                                                                                                                         | 0 / 1          | -            | 1                 | 1                      |
| 143                     | Display of LPB power supply                                                                                                                                                                                                                 | ON / OFF       | -            | -                 | -                      |
| 144                     | Display of LPB communication                                                                                                                                                                                                                | ON / OFF       | -            | -                 | -                      |
| 145                     | Range of action of central changeover<br>0 In the segment<br>1 In the system (if segment address = 0)                                                                                                                                       | 0 / 1          | -            | 1                 | 1                      |
| 146                     | Automatic summer / winter changeover<br>0 Effect on local heating circuit only<br>1 Central changeover of all heating circuits                                                                                                              | 0 / 1          | -            | 1                 | 0                      |
| 147                     | Central standby switch<br>0 OFF (Inactive)<br>1 ON (all units on standby)                                                                                                                                                                   | 0 / 1          | -            | 1                 | 0                      |
| 148                     | Clock mode<br>0 Autonomous clock<br>1 System time without remote adjustment<br>2 system time with remote adjustment<br>3 System clock (master)                                                                                              | 0...3          | -            | 1                 | 3                      |
| <b>Input H1</b>         |                                                                                                                                                                                                                                             |                |              |                   |                        |
| 170                     | Input H1<br>0 Changeover of operating mode (HC standby / d.h.w. off)<br>1 Changeover of operating mode (HC standby)<br>2 Minimum setpoint of flow temperature (setting on line 171)<br>3 Heat generation lock<br>4 Demand for heat 0...10 V | 0...4          | -            | 1                 | 0                      |
| 171                     | Minimum setpoint of flow temperature contact H1<br>If activated at input H1 (setting 2)                                                                                                                                                     | 8...TKmax      | °C           | 1                 | 70                     |
| 172                     | Maximum value of heat demand<br>If activated at input H1 (setting 4)                                                                                                                                                                        | 5...130        | °C           | 1                 | 100                    |
| 173                     | Operating action of contact H1<br>0 N.C. contact<br>1 N.O. contact                                                                                                                                                                          | 0 / 1          | -            | 1                 | 1                      |

## 2.6 Parameter settings for the OEM

### Description

Boiler-specific settings and protective functions for the boiler manufacturer.

### Setting

|   | Buttons                                                                                  | Explanation                                                                                                                                                                                                                                                                                                                                                                                                                                                                            | Line                                                                                  |
|---|------------------------------------------------------------------------------------------|----------------------------------------------------------------------------------------------------------------------------------------------------------------------------------------------------------------------------------------------------------------------------------------------------------------------------------------------------------------------------------------------------------------------------------------------------------------------------------------|---------------------------------------------------------------------------------------|
| 1 |         | Press one of the line selection buttons.<br><i>This will take you first to the programming mode "End-user".</i>                                                                                                                                                                                                                                                                                                                                                                        |    |
| 2 | <br>9 s | Press both line selection buttons for at least 9 seconds.<br>A special display for entering the code will appear.                                                                                                                                                                                                                                                                                                                                                                      |    |
| 3 | <b>CODE</b>                                                                              | Press buttons  and  to enter the required combination of the access code.<br><i>If the combination of buttons is correct, you reach the programming mode "OEM".</i><br><br>➔ Wrong code:<br>If the code has been entered incorrectly, the display will change to the "Parameter settings for the heating engineer". |                                                                                       |
| 4 |       | Press the line selection buttons to select the required line.<br><i>The parameter list on the next two pages contains all available lines.</i>                                                                                                                                                                                                                                                                                                                                         |  |
| 5 |       | Press the plus or minus button to set the required value.<br>The setting will be stored as soon as you leave the programming mode or change to another line.<br><i>The following parameter list contains all available lines.</i>                                                                                                                                                                                                                                                      |                                                                                       |
| 6 |       | You leave the programming level "OEM" by pressing any of the operating mode buttons.<br><br>➔ Note:<br><i>If no button is pressed for about 8 minutes, the controller will automatically return to the operating mode selected last.</i>                                                                                                                                                                                                                                               | Continuous display                                                                    |

## Example

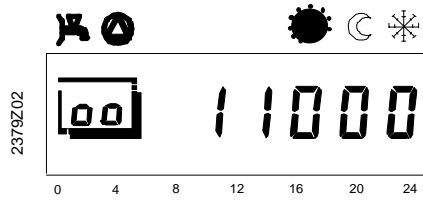

Whether correct or incorrect, each push of a button represents irrevocably a digit of the code. As a confirmation, the respective digit changes to 1.

## 2.6.1 Overview of OEM parameters

| Line                              | Function                                                                                                                                                                                                             | Range                   | Unit   | Resolution | Factory setting |
|-----------------------------------|----------------------------------------------------------------------------------------------------------------------------------------------------------------------------------------------------------------------|-------------------------|--------|------------|-----------------|
| <b>Heat generation values OEM</b> |                                                                                                                                                                                                                      |                         |        |            |                 |
| 1                                 | Minimum limitation of boiler temperature (TK <sub>min</sub> OEM)                                                                                                                                                     | 8...95                  | °C     | 1          | 8               |
| 2                                 | Maximum limitation of boiler temperature (TK <sub>max</sub> )                                                                                                                                                        | 8...120                 | °C     | 1          | 80              |
| 8                                 | Pump overrun time<br>(after burner OFF)                                                                                                                                                                              | 0...20                  | min    | 1          | 5               |
| 22                                | Minimum limitation of boiler return temperature                                                                                                                                                                      | 8...95                  | °C     | 1          | 8               |
| 25                                | Calibration of actual output range of BMU 1                                                                                                                                                                          | -100...100              | -      | 1          | 0               |
| 26                                | Calibration of actual output value BMU 2                                                                                                                                                                             | -100...100              | -      | 1          | 0               |
| 27                                | Calibration of actual output value BMU 3                                                                                                                                                                             | -100...100              | -      | 1          | 0               |
| 28                                | Calibration of actual output value BMU 4                                                                                                                                                                             | -100...100              | -      | 1          | 0               |
| <b>Space heating OEM</b>          |                                                                                                                                                                                                                      |                         |        |            |                 |
| 30                                | Gain factor for room temperature influence (KORR)                                                                                                                                                                    | 0...20                  | -      | 1          | 4               |
| 31                                | Constant for quick setback (KON)<br>(without room temperature sensor)                                                                                                                                                | 0...20                  | -      | 1          | 2               |
| 32                                | Boost of room temperature setpoint<br>(with boost heating)                                                                                                                                                           | 0...20                  | K (°C) | 1          | 5               |
| 33                                | Frost protection for the plant<br>0 Inactive<br>1 Active                                                                                                                                                             | 0 / 1                   | -      | 1          | 1               |
| 34                                | Overtemperature protection pump heating circuit<br>0 Inactive<br>1 Active                                                                                                                                            | 0 / 1                   | -      | 1          | 1               |
| 35                                | Heat gains (Tf)                                                                                                                                                                                                      | -2...+4                 | °C     | 0.1        | 0               |
| 36                                | Adaptation sensitivity 1                                                                                                                                                                                             | 1...15                  | -      | 1          | 15              |
| 37                                | Adaptation sensitivity 2                                                                                                                                                                                             | 1...15                  | -      | 1          | 15              |
| <b>D.h.w. values OEM</b>          |                                                                                                                                                                                                                      |                         |        |            |                 |
| 40                                | Maximum nominal setpoint of d.h.w. temperature<br>(TBW <sub>max</sub> )                                                                                                                                              | 8...80                  | °C     | 1          | 60              |
| 41                                | Switching differential of d.h.w. temperature                                                                                                                                                                         | 0...20                  | K (°C) | 1          | 5               |
| 42                                | Legionella function<br>0 = OFF<br>1 = ON                                                                                                                                                                             | 0 / 1                   | -      | 1          | 1               |
| 43                                | Setpoint of legionella function                                                                                                                                                                                      | 8...95                  | °C     | 1          | 65              |
| 44                                | Protection against discharging during d.h.w. heating<br>0 = no protection against discharging<br>1 = always protection against discharging<br>2 = protection against discharging only when heat generation is locked | 0...2                   | -      | 1          | 2               |
| <b>Cascade settings OEM</b>       |                                                                                                                                                                                                                      |                         |        |            |                 |
| 50                                | Cascade management strategy<br>1 autonomous 1<br>2 autonomous 2<br>3 autonomous 3<br>4 linked 1<br>5 linked 2<br>6 linked 3                                                                                          | 1...6                   | -      | 1          | 2               |
| 51                                | Lower limit of output range (P <sub>min</sub> )                                                                                                                                                                      | 0...P <sub>max</sub>    | %      | 1          | 40              |
| 52                                | Upper limit of output range (P <sub>max</sub> )                                                                                                                                                                      | P <sub>min</sub> ...100 | %      | 1          | 90              |
| 56                                | Mandatory time on basic stage when boilers are added                                                                                                                                                                 | 10...1200               | s      | 10         | 60              |
| 60                                | Minimum temperature differential at the pressureless header                                                                                                                                                          | 0...20                  | K (°C) | 1          | 4               |
| <b>Configuration of plant</b>     |                                                                                                                                                                                                                      |                         |        |            |                 |
| 90                                | Continuous display<br>0 Weekday / time of day<br>1 Actual value of cascade flow temperature                                                                                                                          | 0 / 1                   | -      | 1          | 0               |

| <i>Line</i>           | <i>Function</i>        | <i>Range</i> | <i>Unit</i> | <i>Resolution</i> | <i>Factory setting</i> |
|-----------------------|------------------------|--------------|-------------|-------------------|------------------------|
| <i>General Values</i> |                        |              |             |                   |                        |
| 91                    | Software version       | 00.0...99.9  | -           | 1                 | -                      |
| 92                    | Device operating hours | 0...500000   | h           | 1                 | -                      |

## 2.7 Operation

### Introduction

Operating instructions are inserted at the rear of the unit's front cover.

### 2.7.1 Operating elements

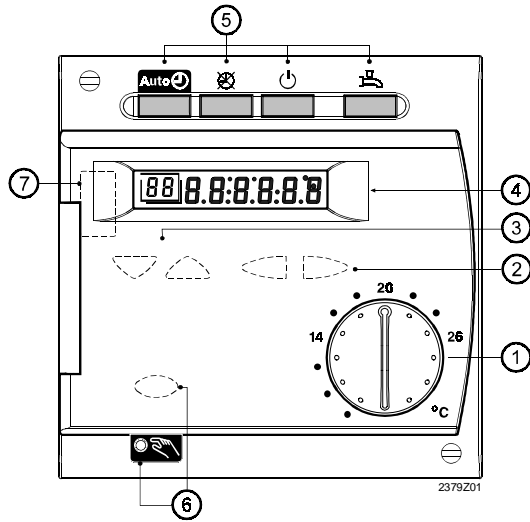

| Operating element                               | Function                                                                                                                                     |
|-------------------------------------------------|----------------------------------------------------------------------------------------------------------------------------------------------|
| ① Room temperature setpoint knob                | Adjustment of room temperature setpoint                                                                                                      |
| ② Setting buttons                               | Parameter settings                                                                                                                           |
| ③ Line selection buttons                        | Selection of parameters / switching of lines                                                                                                 |
| ④ Display                                       | Readout of actual values and settings                                                                                                        |
| ⑤ Operating mode buttons                        | Operating mode changes to:<br>Automatic operation<br>Continuous operation<br>Standby<br>D.h.w. heating ON / OFF<br>Manual operation ON / OFF |
| ⑥ Function button with LED for manual operation |                                                                                                                                              |
| ⑦ Connection facility for PC tool               | Diagnostics and service                                                                                                                      |

### Display

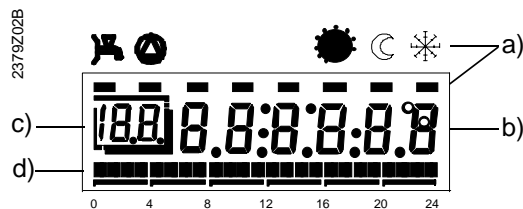

- a) Symbols for indicating the operational status with the black bars (level pointers)  
When the ECO function is active, the current level pointer flashes.
- b) Display during normal control mode or when making settings
- c) Programming line when making settings.
- d) Time bar for normal control mode or when making settings.

## 2.8 Operational faults

### No display on the controller:

- Is the heating plant's mains isolator switched on?
- Are the fuses in order?
- Check the wiring

### Controller displays the wrong time of day:

- Set the correct time of day on the controller (operating line 1).
- Set the correct time of day on the clock master (if present).

### One of the BMUs does not switch on

- Does the BMU really have to operate? (Check cascade lead strategy, delayed switching on?)
- Press BMU's lockout reset button.
- Check the electromechanical control thermostat (TR) and manual reset safety limit thermostat (STB)
- Check wiring and fuse of the BMU.
- Check communication link to the BMU (operating line 54)
- Check wiring of the cascade temperature sensors (sensor test, operating line 52).

### One of the pumps does not run

- Is the right type of plant displayed (operating line 53)?
- Is the pump correctly defined? (Operating line 95)
- Check wiring and fuse of the pump (relay test, operating line 51)
- Check wiring of the sensors (sensor test, operating line 52)

### D.h.w. is not being heated:

- Has the button for d.h.w. heating been activated?
- Check setpoint of the d.h.w. temperature
- Check if d.h.w. heating is released
- Check wiring and fuse of the charging pump (relay test, operating line 51)
- Check wiring of the d.h.w. temperature sensor (sensor test, operating line 52)
- Check setting of the electromechanical control thermostat (TR) installed on the boiler. It must be above the TKmax setting

### The room temperature does not agree with the required temperature level:

- Does the room temperature setpoint agree with the required temperature level? (Knob on the controller or on the room unit)
- Is the required operating mode indicated?
- Are weekday, time of day, and the displayed heating program correct? (Operating lines 1...11)
- Has the heating curve slope been correctly set? (Operating line 17)
- Check wiring of outside sensor (operating line 52)
- Has the "Setting knob for the nominal room temperature setpoint" with the "Parallel displacement of the heating curve" (operating line 100) been calibrated based on the effective room temperature?

### Fault status signal; display shows "ER"

- Select operating line 50 which gives you the error code and error address. Dort sehen Sie den Fehlercode und die Adresse des Fehlers. Refer to section "Indication of errors" for a list of the possible error codes and their descriptions.

# 3 Description of end-user settings

→ For an overview of the settings and setting procedure, refer to page 22

## User interface

### 3.1 Operating modes of heating circuit

**Benefit**

- Straightforward selection of heating circuit operating modes

**Description**

The control provides three different heating circuit operating modes that can be directly selected as required.

**Setting**



Select the required operating mode by pressing the respective operating mode button on the unit front. It is located on the controller front for direct access by the user.



**Effect**

| Operating mode | Designation          | Effect of mode selected                                                                                                                                                                                                                                                                                                                                           |
|----------------|----------------------|-------------------------------------------------------------------------------------------------------------------------------------------------------------------------------------------------------------------------------------------------------------------------------------------------------------------------------------------------------------------|
|                | Automatic operation  | <ul style="list-style-type: none"> <li>• Heating according to the time program (lines 5 to 11)</li> <li>• Temperature setpoints according to the heating program</li> <li>• Protective functions active</li> <li>• Changeover on the room unit active</li> <li>• Automatic summer / winter changeover (ECO) and automatic 24-hour heating limit active</li> </ul> |
|                | Continuous operation | <ul style="list-style-type: none"> <li>• Heating mode with no time program</li> <li>• Temperature adjustment with the setpoint knob</li> <li>• Protective functions active</li> <li>• Changeover on room unit <b>inactive</b></li> <li>• Automatic summer / winter changeover (ECO) and automatic 24-hour heating limit <b>inactive</b></li> </ul>                |
|                | Standby              | <ul style="list-style-type: none"> <li>• Heating OFF</li> <li>• Temperature according to frost protection</li> <li>• Protective functions active</li> <li>• Changeover on room unit <b>inactive</b></li> </ul>                                                                                                                                                    |



## Illuminated buttons

The selected operating mode is indicated by illuminated buttons. Various functions can cause the displayed selection to change. The table below shows the possible statuses.

### Settings on the controller

| <i>Function</i>                                      | <i>Effect of button and meaning</i>                                                                                                                                                                                                                                                    |
|------------------------------------------------------|----------------------------------------------------------------------------------------------------------------------------------------------------------------------------------------------------------------------------------------------------------------------------------------|
| Heat generation lock<br>Line 170 = 3                 | <ul style="list-style-type: none"> <li>Selected <b>HC operating mode button flashes</b> when contact H1 is closed</li> <li><b>D.h.w. operating mode button flashes</b> when switched on</li> </ul>                                                                                     |
| Changeover of operating mode<br>Line 170 = 0         | <ul style="list-style-type: none"> <li>Selected <b>HC operating mode button  flashes</b> when contact H1 is closed</li> <li><b>D.h.w. operating mode button flashes</b> when switched on</li> </ul> |
| Changeover of operating mode<br>Line 170 = 1         | <ul style="list-style-type: none"> <li><b>HC operating mode  flashes</b></li> <li><b>D.h.w. operating mode button</b> will not be affected</li> </ul>                                               |
| Minimum setpoint of flow temperature<br>Line 170 = 2 | <ul style="list-style-type: none"> <li>Selected <b>HC operating mode button flashes</b> when contact H1 is closed.</li> <li><b>D.h.w. operating mode button</b> will not be affected</li> </ul>                                                                                        |
| Central standby switch<br>Line 147 = 1               | <ul style="list-style-type: none"> <li><b>HC operating mode  flashes</b></li> <li><b>D.h.w. operating mode button</b> will not be affected</li> </ul>                                               |

### Settings on the room unit

| <i>Function</i>  | <i>Auswirkung auf Taste und Bedeutung</i>                                                                                                                                                                                                                                       |
|------------------|---------------------------------------------------------------------------------------------------------------------------------------------------------------------------------------------------------------------------------------------------------------------------------|
| Occupancy button | <ul style="list-style-type: none"> <li><b>HC operating mode  flashes</b>, when occupancy button is activ.</li> <li><b>D.h.w. operating mode button</b> will not be affected</li> </ul>     |
| Holiday function | <ul style="list-style-type: none"> <li><b>HC operating mode  flashes</b>, when holiday function is activ.</li> <li><b>D.h.w. operating mode button flashes</b> when switched on</li> </ul> |

## Effect of room unit

Changeover of the operating mode on the room unit is active only if the controller is in automatic mode .

The room temperature is transmitted to the controller via PPS, independent of the selected operating mode.

## 3.2 Operating mode of d.h.w. heating

---

### Benefits

- Selection of d.h.w. heating mode independent of heating operation
  - Selection is made directly on the user interface
- 

### Description

D.h.w. heating can be switched on and off independent of the other operating modes.

---

### Setting



D.h.w. heating is selected by pressing the respective button on the controller's user interface.

---

### Effect

By pressing the respective button, d.h.w. heating is switched on or off.

- D.h.w. heating **OFF** - button dark.  
D.h.w. is not being heated. Frost protection remains active, however, and prevents the storage tank temperature from falling below a certain level
  - D.h.w. heating **ON** - button illuminated.  
The d.h.w. is heated according to the settings made
- 

### Important settings

The following settings affect d.h.w. heating:

- Time switch program d.h.w. heating (lines 29...35)
- Nominal d.h.w. temperature setpoint (line 13)
- Reduced d.h.w. temperature setpoint (line 120)
- Release of d.h.w. heating at the nominal setpoint (line 121)
- Assignment of d.h.w. heating (line 123)
- D.h.w. heating (line 124)
- Type of d.h.w. demand (line 125)

### → Note

The d.h.w. values that can be adjusted on the controller apply to both d.h.w. heating by the controller and d.h.w. heating by a BMU supplied by Landis & Staefa. Some BMUs of other manufacture also support this function.

### 3.3 Nominal room temperature setpoint

#### Benefit

- Straightforward setting of the required nominal room temperature setpoint

#### Description

The heating system uses three different setpoints that can be adjusted:

- The nominal room temperature setpoint described here
- The reduced room temperature setpoint (setting on line 14)
- The frost protection setpoint of the room temperature (setting on line 15)

#### Setting

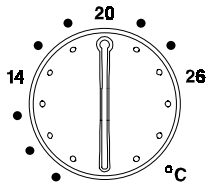

The nominal room temperature setpoint is preadjusted with the setpoint knob, which is located on the controller front for direct access by the user.

| Setting range | Unit | Factory setting |
|---------------|------|-----------------|
| 8...26        | °C   | 20              |



2379Z17

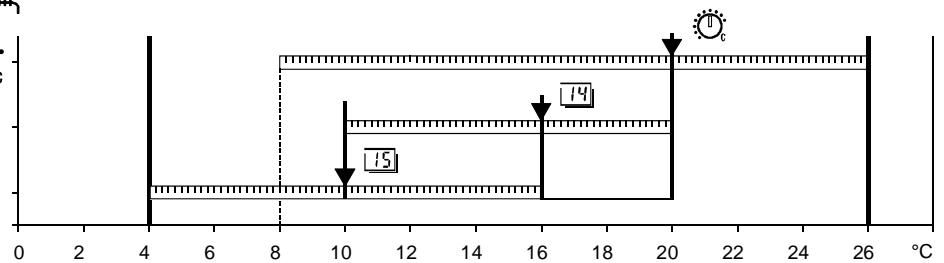



Room temperature setpoint setting ranges

- 14 Setting "Reduced room temperature setpoint"  
 15 Setting "Frost protection setpoint of the room temperature"

#### Effect of temperature setting

When the nominal room temperature setpoint is active, the rooms will be heated according to the adjustment made with the setpoint knob.

Effect in the various operating modes:

| Operating mode                                                                      | Effect of knob adjustment              |
|-------------------------------------------------------------------------------------|----------------------------------------|
|  | Adjustment acts on the heating periods |
|  | Adjustment acts continuously           |
|  | Adjustment has no effect               |

#### Note

The adjustment made with the setpoint knob has priority over the reduced room temperature setpoint entered (line 14). Especially in that situation when the adjustment made with the knob is lower.

## Example

During the heating periods, the nominal room temperature setpoint is maintained. The heating periods are in accordance with the settings made on lines 6 to 11.

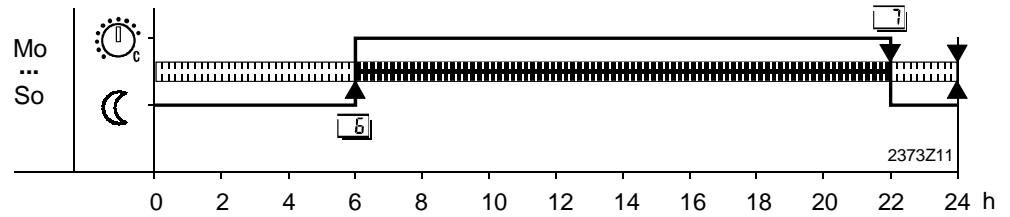

## Room unit

When using a room unit without setpoint readjustment (QAA50), the setpoint knob on the controller acts as described above.

When using a room unit featuring setpoint readjustment (QAA70), the setpoint knob on the controller is inactive. In that case, the nominal setpoint adjusted on the room unit applies.

A connected room unit is active only if operating mode **Auto**  is selected on the controller.

## 3.4 Manual operation

### Benefit

- Partly manual heating operation

### Description

Manual operation is an operating mode in which the peripheral devices on the consumer side must be manually adjusted and monitored. The control functions of the unit are only used for controlling the BMUs.

### Common flow temperature

The BMUs are released and use their boiler temperature sensor to control the temperature at the level of the maximum limitation of the BMU setpoint (TKmax.) Factory setting 80°C. The actual boiler temperatures are displayed on setting line 55.

### Setting



Activation: Manual operation is activated by pressing this button. It is accessible only when the cover of the controller is open

- Deactivation:
- By pressing one of the operating mode buttons
  - By pressing again the manual operation button

### → Note

When deactivating the function, the controller will automatically return to the operating mode previously selected.

### Effect

As soon as manual operation is selected, all relays will switch to the following statuses:

| <i>Output</i>                    | <i>Terminals</i> | <i>Status</i>                                    |
|----------------------------------|------------------|--------------------------------------------------|
| BMU                              | PPS              | All boilers released, fixed heat demand at TKmax |
| Heating circuit or primary pump: | Q1               | ON (uncontrolled)                                |
| D.h.w. charging pump             | Q3               | ON (uncontrolled)                                |

TKmax = maximum limitation of BMU setpoint (operating line 2<sub>OEM</sub>)

### Display

Common flow temperature (cascade flow temperature):

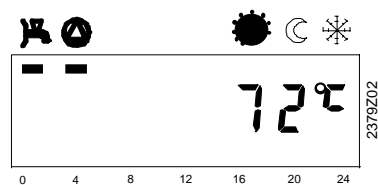

## Setting the clock

---

### Benefits

- Straightforward changeover from summer- to wintertime, and vice versa
  - Fast and easy-to-understand settings of time
- 

### Description

To ensure the proper operation of the heating program, the 24-hour time switch with the time of day and weekday must be correctly set.

---

### System time

The clock time can be set from a remote location via the bus system, provided clock operation is appropriately set. Also refer to clock operation on operating line 148.

---

## 3.5 Time of day

---

### Setting



1. Press the line selection buttons to select line 1.
2. Press the plus / minus buttons to set the time of day.

| <u>Setting range</u> | <u>Unit</u>   |
|----------------------|---------------|
| 00:00...23:59        | Hour : minute |

---

### Effect

The controller's clock time is set in agreement with the correct time. This setting is important to make certain the controller's heating program will operate correctly.

### → Notes

- During the setting procedure, the clock continues to run
  - Each time the plus or minus button is pressed, the seconds are reset to zero
- 

## 3.6 Weekday

---

### Setting



1. Press the line selection buttons to select line 2.
2. Press the plus / minus buttons to select the weekday.

| <u>Setting range</u> | <u>Unit</u> |
|----------------------|-------------|
| 1...7                | day         |

---

### Effect

The time of day will be set to the selected weekday. This setting is important to make certain the controller's heating program will operate correctly.

### Weekday table

|   |   |           |   |   |          |
|---|---|-----------|---|---|----------|
| 1 | = | Monday    | 5 | = | Friday   |
| 2 | = | Tuesday   | 6 | = | Saturday |
| 3 | = | Wednesday | 7 | = | Sunday   |
| 4 | = | Thursday  |   |   |          |

## Time switch program for space heating

### Benefits

- The heating system operates only if there is a demand for heat
- The user can set the heating periods to suit his lifestyle
- Energy can be saved by making adequate use of the heating program

### Description

The time switch program for space heating consists of the switching times that can be entered for the weekdays or the 7-day block.

The time switch program for space heating and the time switch program for d.h.w. heating operate independently of one another.

## 3.7 Preselection of weekday

### Description

With this setting, you select the weekdays or the 7-day block for which the switching times of the time switch program apply.

The heating program thus set becomes active when selecting automatic mode **Auto**.

### Setting



1. Press the line selection buttons to select line 5.
2. Press the plus / minus buttons to preselect the 7-day block or the individual day.

| Setting range | Unit            |
|---------------|-----------------|
| 1-7           | 7-day block     |
| 1...7         | Individual days |

### Important

- This setting must be made before the switching times are entered!
- For every day on which other switching times shall apply, the preselection of the individual day with subsequent entry of the switching times must be repeated

### Effect

This setting is used to select either the whole week (1-7) or individual days (1...7).

### Entry of 1-7

#### 7-day block

Entry of the switching times from line 6 to 11 is identical for every day from Monday through Sunday.

### Example:

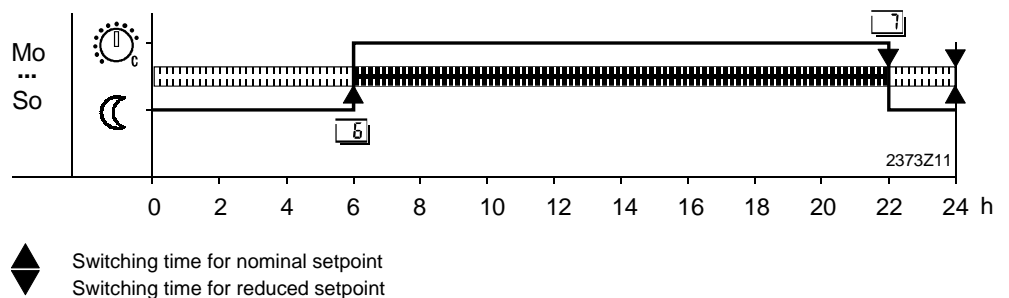

### Individual days

The setting of the switching times from line 6 to 11 is entered **only** for the individual day selected here.

→ *Tip*

First, choose the 7-day block (1-7) to enter the switching times that apply to the majority of days; then, select the individual days (1...7) to make the required adjustments.

Example:

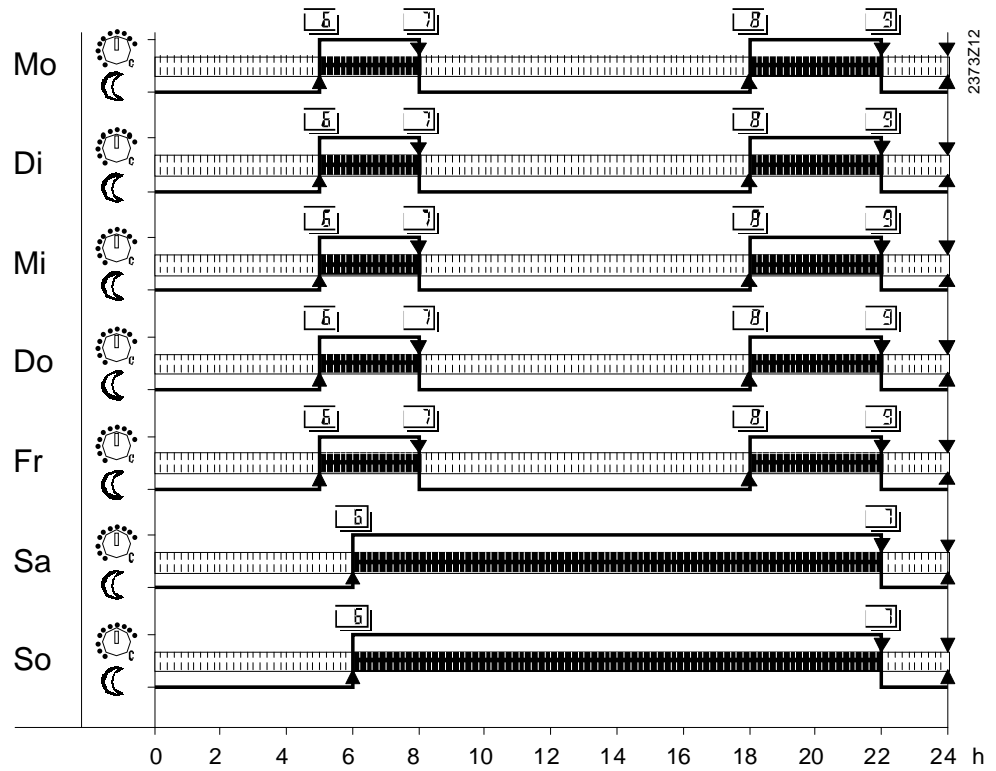

## 3.8 Switching times

### Description

With this setting, you determine the switching times for space heating. At these switching times, the temperature setpoints of the heating circuit change.

The heating program thus set becomes active when selecting automatic mode .

### Setting



1. Press the line selection buttons to select line 6 to 11.
2. Press the plus / minus buttons to set the switching time on each line.

| <i>Setting range</i> | <i>Unit</i> | <i>Factory setting</i>       |
|----------------------|-------------|------------------------------|
| --:--...24:00        | h : min     | See "Program overview" below |

### ! Important

First, select the weekday (line 5) for which the switching times shall be entered!

### → Note

The controller makes a final check to ensure the entries have been made in the correct order.

### Effect

At the times entered, the program will switch to the respective temperature setpoints. The table below shows at what times the setpoints will be activated.

Entry:







--:--

Switching point inactive

00:00...24:00

At the time entered, heating to the respective temperature is ensured.

### Program overview

| <i>Line</i>                                                                         | <i>Switching point</i>   | <i>Temperature setpoint</i> | <i>Standard</i> |
|-------------------------------------------------------------------------------------|--------------------------|-----------------------------|-----------------|
|  | Switch-on time period 1  | Setpoint of knob            | 06:00           |
|  | Switch-off time period 1 | Reduced setpoint            | 22:00           |
|  | Switch-on time period 2  | Setpoint of knob            | --:--           |
|  | Switch-off time period 2 | Reduced setpoint            | --:--           |
|  | Switch-on time period 3  | Setpoint of knob            | --:--           |
|  | Switch-off time period 3 | Reduced setpoint            | --:--           |

### Effect of room unit

When using a QAA70 room unit, the heating program will be acted upon. However, this works only if automatic mode is selected on the controller.

## D.h.w. values

### 3.9 Nominal setpoint of d.h.w. temperature

#### Benefits

- D.h.w. heating only if there is a demand for it
- Possibility of using two different d.h.w. temperature setpoints

#### Setting

13

1. Press the line selection buttons to select line 13.
2. Press the plus / minus buttons to adjust the nominal setpoint of the d.h.w. temperature.

| <i>Setting range</i> | <i>Unit</i>                                                                         | <i>Factory setting</i> |
|----------------------|-------------------------------------------------------------------------------------|------------------------|
| TBWR...TBWmax        | °C                                                                                  | 55                     |
| TBWR                 | Reduced setpoint of d.h.w. temperature (setting on line 120)                        |                        |
| TBWmax               | Maximum nominal setpoint of d.h.w. temperature (setting on line 40 <sub>OEM</sub> ) |                        |

#### Effect

The temperature setpoint during normal d.h.w. operation will be changed.

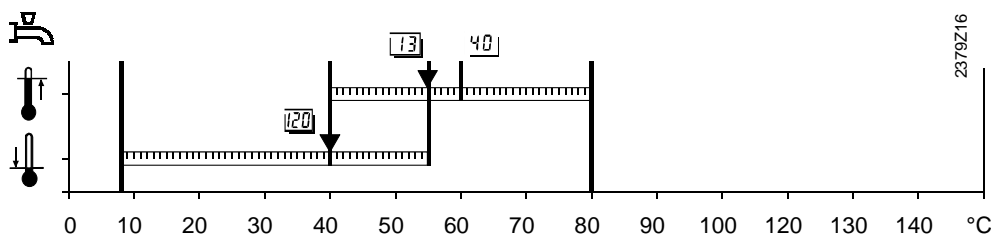

- 13 Setting "Nominal setpoint of d.h.w. temperature"  
120 Setting "Reduced setpoint of d.h.w. temperature"  
40<sub>OEM</sub> Setting "Maximum nominal setpoint of d.h.w. temperature"

#### D.h.w. temperature setpoints

D.h.w. heating has two different setpoints that can be used:



- Nominal setpoint of d.h.w. temperature: It ensures the d.h.w. temperature required during main occupancy times



- Reduced setpoint of d.h.w. temperature (setting on line 120): It ensures the d.h.w. temperature required during non-occupancy times

#### D.h.w. charging

The criteria required for releasing d.h.w. heating are defined by the settings made on lines 121 and 123 and 124.

#### → Note

In the event of a sensor with a short-circuit (display "--" in input test, test step 1) the d.h.w. will not be heated (protection against scalding).

## Heating circuit values

### 3.10 Reduced room temperature setpoint

#### Benefits

- Lower room temperatures during non-occupancy times, e.g. during the night
- Energy savings

#### Description

The heating system has three different setpoints that can be adjusted:

- The reduced room temperature setpoint described here
- The nominal room temperature setpoint (set with the setpoint knob)
- The frost protection setpoint of the room temperature (setting on line 15)

#### Setting

14

1. Press the line selection buttons to select line 14.
2. Press the plus / minus buttons to adjust the reduced room temperature setpoint.

| Setting range | Unit                                                                   | Factory setting |
|---------------|------------------------------------------------------------------------|-----------------|
| TRF...TRN     | °C                                                                     | 16              |
| TRF           | Frost protection setpoint of the room temperature (setting on line 15) |                 |
| TRN           | Nominal room temperature setpoint (adjusted with the setpoint knob)    |                 |

#### → Note

If the required temperature level cannot be set, the adjustment made with the setpoint knob may be too low. It is not possible to set a value above the adjustment made with the setpoint knob.

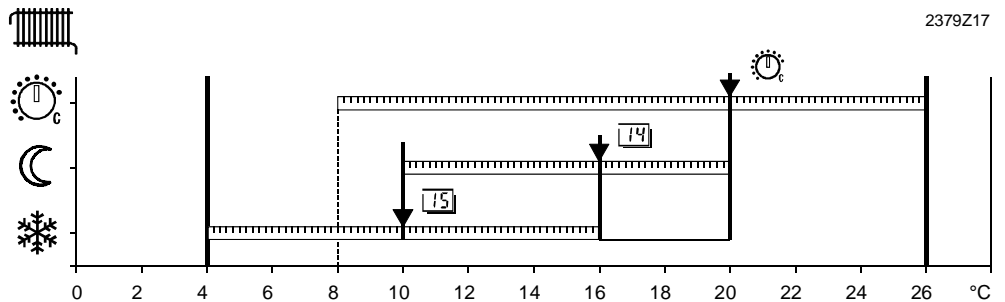

Room temperature setpoint setting ranges

- 14 Setting "Reduced room temperature setpoint"
- 15 Setting "Frost protection setpoint of the room temperature"

#### Effect

With this setting, the reduced room temperature setpoint will change to the level called for by reduced operation  in the living rooms.

#### Example

The heating periods are in accordance with the settings made on lines 6 to 11.

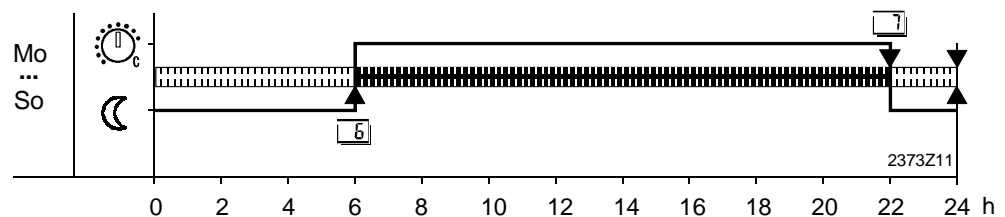

## 3.11 Frost protection setpoint of the room temperature

### Benefit

- Protection of building against frost



Caution

This function is ensured only when the heating plant operates properly!

### Description

This function prevents the room temperature from falling below the adjusted frost protection setpoint.

### Setting



1. Press the line selection buttons to select line 15.
2. Press the plus / minus buttons to adjust the frost protection setpoint of the room temperature.



| <i>Setting range</i> | <i>Unit</i> | <i>Factory setting</i> |
|----------------------|-------------|------------------------|
| 4...TRRw             | °C          | 10                     |

TRRw Reduced room temperature setpoint (setting one line 14)

### Effect

This setting will change the frost protection setpoint of the room temperature.

### Frost protection for the building

In operating mode , the room temperature is prevented from falling below a certain level. This means that the frost protection setpoint  of the room temperature will be maintained.

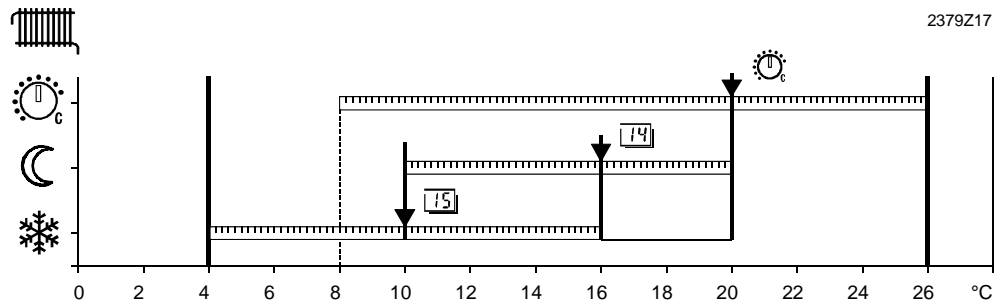

Room temperature setpoint setting ranges

- 14 Setting "Reduced room temperature setpoint"
- 15 Setting "Frost protection setpoint of the room temperature"

## 3.12 Summer / winter changeover temperature of the heating circuit

### Benefits

- Fully automatic operation throughout the year
- The heating will not be switched on when the outside temperature drops for short periods of time
- Additional savings function

### Description

The summer / winter changeover temperature is the criterion for automatic summer / winter changeover of the heating plant.

### Setting

16

1. Press the line selection buttons to select line 16.
2. Press the plus / minus buttons to select the summer / winter changeover temperature.

| <i>Setting range</i> | <i>Unit</i> | <i>Factory setting</i> |
|----------------------|-------------|------------------------|
| 8...30.0             | °C          | 17                     |

### Effect



By changing the setting, the respective periods of time will be shortened or extended. The change will only affect the heating circuit.

Entry:

Increase: Winter operation will start *earlier*  
Summer operation will start *later* .

Decrease: Winter operation will start *later*  
Summer operation will start *earlier*

### → Notes

- The summer / winter changeover temperature can act either locally or on other units in the system (also refer to section "Effect of summer / winter changeover temperature") (Also refer to "Effect of automatic summer / winter changeover" on operating line 91).
- This function only acts in automatic mode  and standby mode .
- Level cursor flashes during summer operation.

### Changeover

To determine changeover, the setting of the summer / winter changeover temperature ( $\pm$  a fixed switching differential) is compared with the attenuated outside temperature. Also refer to section "Attenuated outside temperature".

|                                            |                                |
|--------------------------------------------|--------------------------------|
| Heating <b>OFF</b> (from winter to summer) | $T_{Aged} > SoWi + 1^{\circ}C$ |
| Heating <b>ON</b> (from summer to winter)  | $T_{Aged} < SoWi - 1^{\circ}C$ |

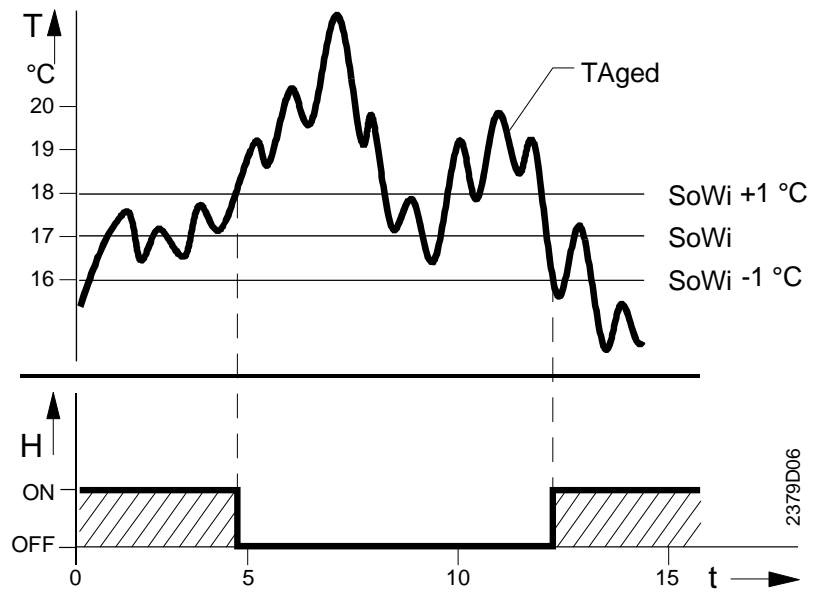

Changeover between summer and winter operation:

TAged Attenuated outside temperature  
 SoWi Summer / winter changeover temperature  
 T Temperature  
 t Time in days  
 H Heating

## 3.13 Slope of heating curve

### Benefits

- Constant room temperature in spite of outside temperature variations
- Generation of a flow temperature with no external demand for heat

### Description

The controller generates the flow temperature setpoint in function of the selected heating curve. For plants where the controllers cannot transmit their demand for heat via LPB or input H1, the controller can generate a weather-compensated flow temperature.

### Setting



1. Press the line selection buttons to select line 17.
2. Press the plus / minus buttons to select the heating curve slope or - - .

| <i>Setting range</i> | <i>Unit</i> | <i>Factory setting</i> |
|----------------------|-------------|------------------------|
| - : - - / 2.5...40.0 | Increment   | 15.0                   |

### Effect

By changing the setting, the slope of the heating curve will be increased or decreased with the following effects:

Increase: The flow temperature will be **raised** when the outside temperature drops

Decrease: The flow temperature will **rise less** when the outside temperature drops

The following settings produce the following effects:

2.5...40.0 The controller delivers a weather-compensated flow temperature.

- : - - The controller delivers no weather-compensated flow temperature. To release heat generation, an external heat demand signal is required. Frost protection for the plant is active, but not frost protection for the building. The settings and the display on the room unit are also deactivated.

### → Notes

The setting of the heating curve slope (value from 2.5 to 40 or inactive - - - ) affects the automatic generation of plant type (operating line 53).

An external demand for heat can be delivered to the controller via LPB (LPB-compatible controllers) or input H1 (controllers of other manufacture). If several signals are present, the controller will use the highest of them as the setpoint.

### The heating curve

Using the heating curve, the controller generates the flow temperature setpoint, enabling the system to maintain a constant room temperature even without using a room temperature detector.

The steeper the slope of the heating curve, the higher the flow temperature setpoint at low outside temperatures.

### → Note

Comfort is considerably enhanced when using a room temperature detector.

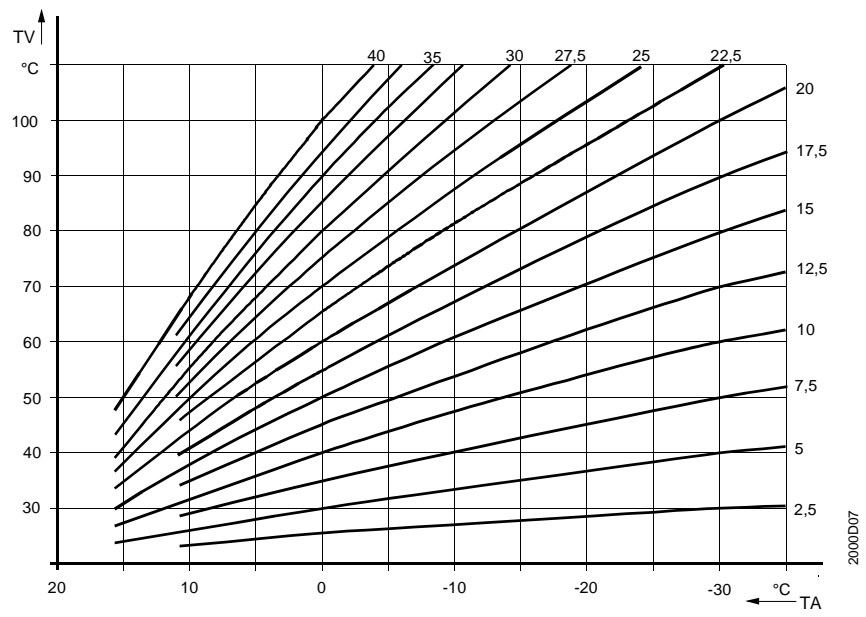

TV Flow temperature  
 TA Composite outside temperature

## Actual values

### Benefits

- Display of the actual room temperature
- Display of the actual outside temperature

### Note

All displays of actual values require the respective temperature detectors.

## 3.14 Actual value of room temperature

### Setting



1. Press the line selection buttons to select line 18.
2. No setting can be made with the plus / minus buttons.

| <u>Display</u> | <u>Unit</u> |
|----------------|-------------|
| 0...50 °C      | °C          |

### Effect

The temperature measured with the room unit will automatically be displayed on this line.

### Special displays

|       |                                                                       |
|-------|-----------------------------------------------------------------------|
| ---   | Sensor with an open-circuit or no room temperature detector connected |
| 0 0 0 | Sensor with a short-circuit                                           |

## 3.15 Actual value of outside temperature

### Setting



1. Press the line selection buttons to select line 19.
2. No setting can be made with the plus / minus buttons.

| <u>Display</u>    | <u>Unit</u> |
|-------------------|-------------|
| - 50.0 ... + 50.0 | °C          |

### Effect

The temperature measured with the outside sensor will automatically be displayed on this line.

### Special displays

|       |                                                      |
|-------|------------------------------------------------------|
| ---   | Detector with an open-circuit or no sensor connected |
| 0 0 0 | Sensor with a short-circuit                          |

### Note

For resetting the attenuated outside temperature to the actual room temperature, refer to section " Attenuated outside temperature".

## Maintenance

### 3.16 Standard time switch program for heating circuit and d.h.w.

#### Benefit

- Straightforward resetting of all time switch programs to their standard values

#### Description

The standard time program resets the time settings of all time switch programs. For this purpose, the controller is supplied with non-volatile factory settings.

#### Setting

**23**

1. Press the line selection buttons to select line 23.
2. Press the plus / minus buttons for 3 seconds.

The standard time program is activated as soon as the display changes to 1.

*Display* \_\_\_\_\_ *Unit* \_\_\_\_\_

0 / 1 -

#### ! Caution

In that case, the individual settings will be lost!

#### Effect

The time settings for the time switch programs will be overwritten with standard values. This applies to the following settings:

- Switching times of time switch program "heating circuit"
- Switching times of time switch program 3

**6** ... **11**

**30** ... **35**

#### Standard values

| <i>Switching point</i> | <i>Setting line</i>    |               | <i>Standard time</i> |
|------------------------|------------------------|---------------|----------------------|
|                        | <i>Heating circuit</i> | <i>D.h.w.</i> |                      |
| Period 1 ON            | 6                      | 30            | 06 : 00              |
| Period 1 OFF           | 7                      | 31            | 22 : 00              |
| Period 2 ON            | 8                      | 32            | --- : ---            |
| Period 2 OFF           | 9                      | 33            | --- : ---            |
| Period 3 ON            | 10                     | 34            | --- : ---            |
| Period 3 OFF           | 11                     | 35            | --- : ---            |

## Time switch program for d.h.w. heating

### Benefits

- D.h.w. is heated only if required
- The user can set the d.h.w. heating times to suit his lifestyle
- Energy can be saved by making adequate use of the time switch program

### Description

The time switch program for d.h.w. consists of the switching times to be entered for the weekdays or the 7-day block.

The time switch program for d.h.w. and the time switch program for space heating operate independently of one another.

### → Important

The time switch program is active only when, on operating line 121 (d.h.w. program), setting 2 has been selected.

## 3.17 Preselection of weekday

### Description

With this setting, you define the weekdays or the 7-day block for which the switching times of the d.h.w. time switch program apply.

The time switch program thus set is activated by pressing the d.h.w. operating mode button .

### Setting

**29**

1. Press the line selection buttons to select line 29.
2. Press the plus / minus buttons to preselect the 7-day block or the individual day.

*Setting range*

*Unit*

1-7

7-day block

1...7

Individual days

### → Important

- This setting must be made before the switching times are entered!
- For every day on which other switching times shall apply, the preselection of the individual day with subsequent entry of the switching times must be repeated

### Effect

This setting is used to select either the whole week (1-7) or individual days (1...7).

Entry:

**1-7** 7-day block: Entry of the switching times on lines 30 to 35 is identical for every day from Monday through Sunday

**1...7** Individual days: Entry of the switching times on lines 30 to 35 is made **only** for the individual day selected here

### Example:

The principle is the same as that used with "Time switch program space heating" (refer to the diagrams and tips on page 41).

## 3.18 Switching times

### Description

This is the setting of the switching times for time switch program d.h.w. at which the d.h.w. temperature setpoint will change.

The time switch program thus set is activated by pressing the d.h.w. operating mode button .

### Setting



1. Press the line selection buttons to select line 30 to 35.
2. Press the plus / minus buttons to set the switching time on each line.

| <u>Setting range</u> | <u>Unit</u> | <u>Factory setting</u>       |
|----------------------|-------------|------------------------------|
| --:--...24:00        | h : min     | See "Program overview" below |

### ! Important

First, select the weekday for which the switching times shall be entered!

### ➔ Note

The controller makes a final check to ensure the entries have been made in the correct order.













### Effect

At the times entered, the program will switch to the respective temperature setpoints. The table below shows at what times the setpoints will be activated.

Entry:

|               |                                                                                  |
|---------------|----------------------------------------------------------------------------------|
| --:--         | Switching point inactive                                                         |
| 00:00...24:00 | At the time entered, the d.h.w. will be heated up to the respective temperature. |

### Program overview

| <i>Line</i>                                                                         | <i>Switching point</i>   | <i>D.h.w temperature setpoint</i>                                                                                | <i>Standard</i> |
|-------------------------------------------------------------------------------------|--------------------------|------------------------------------------------------------------------------------------------------------------|-----------------|
|  | Switch-on time period 1  | Nominal setpoint of d.h.w.  | 06:00           |
|  | Switch-off time period 1 | Reduced setpoint            | 22:00           |
|  | Switch-on time period 2  | Nominal setpoint of d.h.w.  | --:--           |
|  | Switch-off time period 2 | Reduced setpoint            | --:--           |
|  | Switch-on time period 3  | Nominal setpoint of d.h.w.  | --:--           |
|  | Switch-off time period 3 | Reduced setpoint            | --:--           |

## Service

### 3.19 Indication of BMU error code

#### Benefits

- Straightforward checking of plant.
- Fault tracing is made easier

#### Description

For each BMU, the RVA47.320 can log and store one fault status signal with the associated BMU number and error code. The faults are indicated on this operating line.

#### Setting

1. Press the line selection buttons to select line 49.
2. Press the plus / minus buttons to interrogate the individual BMUs.



*Display*

*Unit*

1...4 / 0...255

BMU number / error code

#### Effect

The number of the lowest connected BMU number containing a fault entry will automatically be displayed on this line.

#### → Note

Fault status signals cannot be acknowledged. They disappear only if the appropriate fault has been rectified.

#### Display

The display shows the BMU number and the associated error code. When none of the BMUs delivers a fault status signal, or when no BMU is connected, there will be no display.

The meaning of the different error codes depends of the make of BMU used. For this reason, no overview of all the different error codes can be given here. For details, please refer to the technical documentation of the respective product.

#### Example:

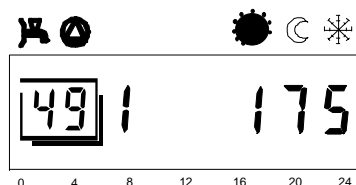

BMU 1 displays error code 175.

#### → Note

If there is a BMU error code, operating line 50 also displays a general BMU fault (error code 150).

## 3.20 Indication of faults

### Benefits

- Straightforward checking of plant
- Fault tracing is made easier

### Description

The controller indicates faults that may have occurred in the controller itself or in the system. In normal operation, the display shows "Er" if a fault has occurred.

### Setting

1. Press the line selection buttons to select line 50.
2. Press the plus / minus buttons to display the list of faults.





| <i>Display</i> | <i>Unit</i> |
|----------------|-------------|
| 0...255        | -           |

### Effect

The first entry in the fault list will automatically be displayed on this line.

### Note

By pressing  , it is possible to switch between fault status signals.

### Fault status signals

The controller can store a maximum of two fault status signals. The faults status signal will be cleared only after the cause of the fault has been removed. If additional faults are present, they will be stored when storage capacity becomes available.

### Device fault

Faults that may occur locally on this device:

| <i>Display</i> | <i>Description of fault</i>                               |
|----------------|-----------------------------------------------------------|
| Blank          | No fault                                                  |
| 10             | Outside sensor                                            |
| 26             | Cascade flow temperature sensor                           |
| 46             | Cascade return temperature sensor                         |
| 50             | D.h.w. temperature sensor                                 |
| 58             | D.h.w. control thermostat                                 |
| 61             | Fault room unit                                           |
| 62             | Wrong room unit                                           |
| 70             | Buffer storage tank temperature sensor                    |
| 81             | Short-circuit LPB                                         |
| 82             | Address collision on LPB (several times the same address) |
| 86             | Short-circuit PPS                                         |
| 100            | Two clock masters present                                 |
| 145            | Wrong device connected to PPS                             |
| 146            | Inadmissible plant configuration                          |
| 147            | No BMU connected                                          |
| 150            | General BMU fault                                         |

### → Note

In the case of error code 150, operating line 49 also gives the manufacturer-specific error code of the BMU.

## Faulty devices

Other devices that are faulty and whose faults are signalled:

| <i>Display</i> | <i>Description of fault</i> |
|----------------|-----------------------------|
|----------------|-----------------------------|

Example:

26.0.01                  Fault with the address of the faulty device

- The first digit gives the error code (26).
- The second digit indicates the segment address of the faulty device (.01).  
(for the segments 10-14, the letters A, b, C, d, and E are used)
- The third digit indicates the device address of the faulty device (.01).

## Display

Example of a display after a fault has occurred:

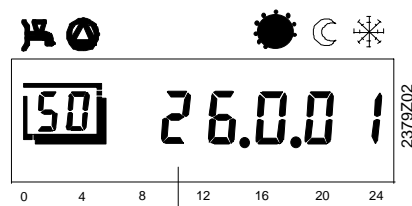

"Er" indicates that a fault has occurred.  
Additional faults can be displayed by pressing



## 4 Description of heating engineer settings

→ For an overview of the settings and the setting procedure, refer to page 24.

### Service values

#### 4.1 Output test

##### Benefits

- Connections can be checked prior to commissioning
- Faults can be pinpointed much faster

##### Description

Also termed relay test, which is used to check the wiring and the configuration.

##### Setting

1. Press the line selection buttons to select line 51.
2. Press the plus / minus buttons to run through the output test.



| <u>Setting range</u> | <u>Unit</u> | <u>Factory setting</u> |
|----------------------|-------------|------------------------|
| 0...3                | Increment   | 0                      |

##### Effect

The output test will automatically become available on this line.

With each test step, the respective output will be activated so that it can be checked.

##### Test sequence

The test sequence is arranged in the form of a ring counter. This means it can be run through either forward or backward by pressing the plus / minus buttons.

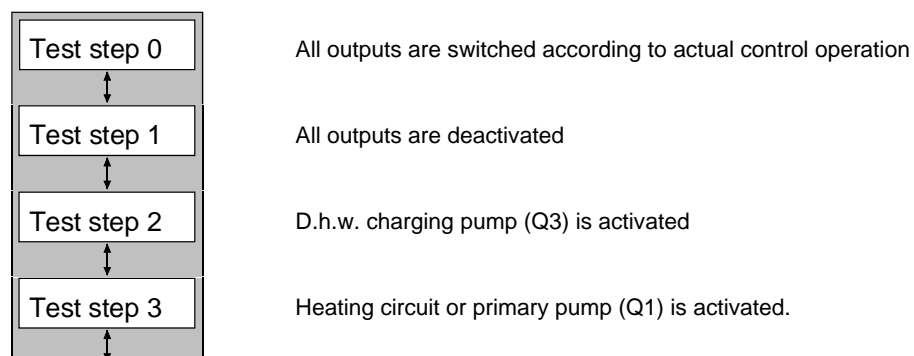

##### Note

For additional information, refer to section "Commissioning".

## 4.2 Input test

### Benefits

- Commissioning is facilitated
- Faults can be pinpointed much faster

### Description

Also termed detector test, which is used to check the wiring and the configuration.

### Setting

1. Press the line selection buttons to select line 52.
2. Press the plus / minus buttons to run through the input test.



| <i>Setting range</i> | <i>Unit</i> | <i>Factory setting</i> |
|----------------------|-------------|------------------------|
| 0...5                | Increment   | 0                      |

### Effect

The input test will automatically become available on this line.

With each test step, the respective value will be displayed so that it can be checked.

### Test sequence

The test sequence is arranged in the form of a ring counter. This means it can be run through either forward or backward by pressing the plus / minus buttons.

|             |                                                                                                |
|-------------|------------------------------------------------------------------------------------------------|
| Test step 0 | Display of the function (B70/B4) [°C] selected on operating line 97.                           |
| ↕           |                                                                                                |
| Test step 1 | Display of the d.h.w. temperature (B3).                                                        |
| ↕           |                                                                                                |
| Test step 2 | Display of the cascade flow temperature (B10).                                                 |
| ↕           |                                                                                                |
| Test step 3 | Display of the actual outside temperature (B9)                                                 |
| ↕           |                                                                                                |
| Test step 4 | Display of room temperature acquired with room unit connected to A6                            |
| ↕           |                                                                                                |
| Test step 5 | Display of input H1 according to the function selected on operating line 170 [°C, ---, o o o]. |

### → Note

For additional information, refer to section "Commissioning".

### Special displays

|       |                                                    |
|-------|----------------------------------------------------|
| ---   | Sensor with an open-circuit or no sensor connected |
| 0 0 0 | Sensor with a short-circuit                        |

## 4.3 Display of plant type

### Benefits

- Plant structure is easy to understand
- Straightforward checking of configuration

### Description

Displays the plant type used.

### Setting

1. Press the line selection buttons to select line 53.
2. No setting can be made with the plus / minus buttons.



| <i>Display</i>      | <i>Unit</i> |
|---------------------|-------------|
| 0, 27...36, 65...67 | -           |

### Effect

The number of the current plant type will automatically be displayed on this line.

|                  |                                |
|------------------|--------------------------------|
| 0                | Invalid configuration of plant |
| 27...36, 65...67 | Valid configuration of plant   |

### Plant type

Based on the connected peripheral devices and parameter settings, the controller ascertains the current plant type.

The plant type is displayed in the form of a number which corresponds to the plant diagram.

Refer to section "Application examples" for the various types of plant.

The following factors influence the generation of the type of plant:

- Connection of a d.h.w. temperature sensor:  
The controller identifies a connected d.h.w. temperature sensor and also whether it is connected directly to the controller or to one of the BMUs.
- Setting of operating line "Type of d.h.w. demand" (line 125)  
Based on this setting, the controller knows whether the d.h.w. is heated by means of a temperature sensor or control thermostat.
- Selection of pump connected to output Q1 (operating line 95)
- Adjustment of heating curve (operating line 17)  
(- - : - or value between 2.5 and 40)

## Combinations

The following table contains the setting combinations that lead to the required types of plant:

| <u>Plant type-number</u><br>(line 53) | <u>Slope of heating curve</u><br>(line 17) | <u>Pump function (output Q1)</u><br>(line 95) | <u>Type of d.h.w. demand</u><br>(line 125) | <u>D.h.w. sensor connected to:</u> |            |
|---------------------------------------|--------------------------------------------|-----------------------------------------------|--------------------------------------------|------------------------------------|------------|
|                                       |                                            |                                               |                                            | <u>BMU</u>                         | <u>RVA</u> |
| 27                                    | ---                                        | Heating circuit pump                          | T. detector                                | No                                 | No         |
| 27                                    | x                                          | D.h.w. circulating pump                       | T. detector                                | No                                 | No         |
| 28                                    | ---                                        | Heating circuit pump                          | T. detector                                | x                                  | Yes        |
| 28                                    | ---                                        | Heating circuit pump                          | Control thermostat                         | x                                  | No         |
| 28                                    | x                                          | D.h.w. circulating pump                       | T. detector                                | x                                  | Yes        |
| 28                                    | x                                          | D.h.w. circulating pump                       | Control thermostat                         | x                                  | No         |
| 29                                    | ---                                        | Heating circuit pump                          | T. detector                                | Yes                                | No         |
| 29                                    | x                                          | D.h.w. circulating pump                       | T. detector                                | Yes                                | No         |
| 30                                    | x                                          | Primary pump for d.h.w. and HC                | T. detector                                | No                                 | No         |
| 30                                    | x                                          | Primary pump for HCs only                     | T. detector                                | No                                 | No         |
| 31                                    | x                                          | Primary pump for d.h.w. and HC                | T. detector                                | x                                  | Yes        |
| 31                                    | x                                          | Primary pump for d.h.w. and HC                | Control thermostat                         | x                                  | No         |
| 32                                    | x                                          | Primary pump for HCs only                     | T. detector                                | x                                  | Yes        |
| 32                                    | x                                          | Primary pump for HCs only                     | Control thermostat                         | x                                  | No         |
| 33                                    | x                                          | Primary pump for d.h.w. and HC                | T. detector                                | Yes                                | No         |
| 33                                    | x                                          | Primary pump for HCs only                     | T. detector                                | Yes                                | No         |
| 34                                    | 2.5...40                                   | Heating circuit pump                          | T. detector                                | No                                 | No         |
| 35                                    | 2.5...40                                   | Heating circuit pump                          | T. detector                                | x                                  | Yes        |
| 35                                    | 2.5...40                                   | Heating circuit pump                          | Control thermostat                         | x                                  | No         |
| 36                                    | 2.5...40                                   | Heating circuit pump                          | T. detector                                | Yes                                | No         |
| 65                                    | x                                          | H1 pump                                       | T. detector                                | No                                 | No         |
| 66                                    | x                                          | H1 pump                                       | T. detector                                | x                                  | Yes        |
| 66                                    | x                                          | H1 pump                                       | Control thermostat                         | x                                  | No         |
| 67                                    | x                                          | H1 pump                                       | T. detector                                | Yes                                | No         |

x means that the setting has no influence on the generation of plant type.

### → Note

If the heating curve is deactivated (setting ---), the controller requires an external heat demand signal to release the generation of heat. An external demand for heat can be transmitted to the controller via LPB (LPB capable controllers) or input H1. If several signals are present, the controller will use the highest of them as the setpoint.

The following settings are invalid, therefore producing fault message 58 (demand from thermostat, but sensor used):

| <u>Plant type-number</u> | <u>Slope of heating curve</u> | <u>Pump function (output Q1)</u> | <u>Type of d.h.w. demand</u> | <u>D.h.w. sensor connected to:</u> |            |
|--------------------------|-------------------------------|----------------------------------|------------------------------|------------------------------------|------------|
|                          |                               |                                  |                              | <u>BMU</u>                         | <u>RVA</u> |
| 28                       | ---                           | Heating circuit pump             | Control thermostat           | x                                  | Yes        |
| 28                       | x                             | D.h.w. circulating pump          | Control thermostat           | x                                  | Yes        |
| 31                       | x                             | Primary pump for d.h.w. and HC   | Control thermostat           | x                                  | Yes        |
| 32                       | x                             | Primary pump for HCs only        | Control thermostat           | x                                  | Yes        |
| 35                       | 2.5...40                      | Heating circuit pump             | Control thermostat           | x                                  | Yes        |
| 66                       | x                             | H1 pump                          | Control thermostat           | x                                  | Yes        |

x means that the setting has no influence on the generation of the type of plant.

## 4.4 Display of PPS communication

### Benefits

- Interface for BMUs and digital room unit
- Checking the communication with the peripheral devices (BMUs, room unit)

### Description

PPS is a point-to-point interface for communication between controller, BMU and room unit. The display provides information about the communication status and the types of connected peripheral devices.

### Setting

1. Press the line selection buttons to select line 54.
2. Press the plus / minus buttons to interrogate the various PPS users.



| <i>Display</i>   | <i>Unit</i>                         |
|------------------|-------------------------------------|
| ---              | No communication                    |
| 1...12 / 0...255 | PPS address / identification code   |
| o o o            | Short-circuit of communication line |

### Effect

The status of the PPS communication will automatically be displayed on this line. If communication is error-free, the controller identifies the unit connected by displaying the identification number, in addition to the device address.

### Display

The display is comprised of PPS address and a device identification code.

### PPS-Adresse

Within the PPS, a fixed PPS address is assigned to some types of devices:

|              |   |   |
|--------------|---|---|
| Room unit    | ⇒ | 1 |
| BMU-Nummer 1 | ⇒ | 4 |
| BMU-Nummer 2 | ⇒ | 5 |
| BMU-Nummer 3 | ⇒ | 6 |
| BMU-Nummer 4 | ⇒ | 7 |

### Note

These peripheral devices can only be operated under the respective PPS address. If one of these devices is not used, the PPS address can be allocated to some other peripheral device.

Assignment of all the other peripheral devices to the PPS addresses can be made randomly.

Since every controller has a specific and confined PPS address space, the same PPS addresses can be assigned to each device.

## Identification code

Only digital peripheral devices can be connected to the controller. Analog devices are not permitted. The digital devices transmit the controller an identification code in agreement with the type of device. The type of device can be identified with the help of the list given below.

|     |                                         |
|-----|-----------------------------------------|
| 82  | Room unit QAA 50 (digital)              |
| 83  | Room unit QAA 70 (digital)              |
| 90  | Room temperature sensor QAA10 (digital) |
| 102 | BMU                                     |

## → Notes

- When the LCD displays a PPS address with identification code, communication with the respective device is error-free.
- When the LCD displays **no** PPS address and **no** identification code, there is no communication or it is faulty.
- Incompatible devices are also displayed, but produce error code 145 (line 50).

## Actual values

---

### Benefits

- Overview of the actual temperatures of the sensors used
- Better reproducibility of the control sequences thanks to visualized temperatures

## 4.5 Actual boiler temperature values of BMUs (TKx)

---

### Setting

1. Press the line selection buttons to select line 55.
2. Press the plus / minus buttons to interrogate the individual BMUs.



| <u>Display</u>  | <u>Unit</u>     |
|-----------------|-----------------|
| 1...4 / 0...140 | BMU number / °C |

---

### Effect

The lowest connected BMU number with the associated temperature will automatically be displayed on this line. The temperatures of the other cascaded heating boilers can be interrogated by pressing the plus / minus buttons. Non-existing BMUs will be skipped.

### → Note

The cascade boilers displayed are only those connected to this controller. If there are additional cascaded boilers, they will be displayed on the controllers to which they are physically connected.

---

### Special displays:

In place of the temperature, the following displays can appear next to the BMU number:

|       |                                                        |
|-------|--------------------------------------------------------|
| ---   | Detector with an open-circuit or no detector connected |
| 0 0 0 | Sensor with a short-circuit                            |

### → Note

If the LCD displays --- without giving an associated BMU number, there is no BMU connected to the controller.

## 4.6 Actual value of cascade flow temperature

### Description

When using several cascaded heat sources, a cascade flow temperature sensor (B10) **must** be installed.

Also termed "Common flow temperature sensor".

### Setting

56

1. Press the line selection buttons to select line 56.
2. No setting can be made with the plus / minus buttons.

| <i>Display</i> | <i>Unit</i> |
|----------------|-------------|
| 0...140        | °C          |

### Effect

The temperature measured with the cascade flow temperature sensor (B10) will automatically be displayed on this line.

### Cascade flow temperature sensor

In a cascaded system, a common cascade flow temperature sensor (B10) is used for all heat sources.

The cascade temperature sensor (B10) is connected directly to the RVA47.320.

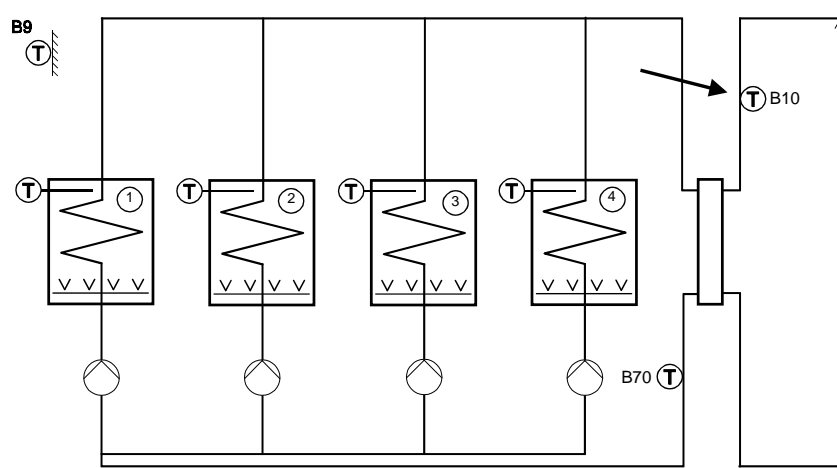

B10 Cascade flow temperature sensor

### Special displays

- Sensor with open-circuit, no sensor connected, or sensor incorrectly defined
- 0 0 0 Sensor with a short-circuit

2379S27

## 4.7 Actual value of cascade return temperature

### Description

When using several cascaded heat sources, we recommend to use a cascade return temperature sensor (B70).

Also termed "Common return temperature sensor".

### Setting

1. Press the line selection buttons to select line 57.
2. No setting can be made with the plus / minus buttons.

57

| Display | Unit |
|---------|------|
| 0...140 | °C   |

### Effect

The temperature measured with the cascade return temperature sensor (B70) will automatically be displayed on this line.

### Cascade return temperature sensor

In a cascaded system, a common cascade return temperature sensor (B70) should be used for all heat sources. The value of this sensor is used for optimizing the controller's functionality. In particular, it permits the detection of wrong mass flows (primary / secondary mass flow).

The cascade return temperature sensor is connected directly to the RVA47.320.

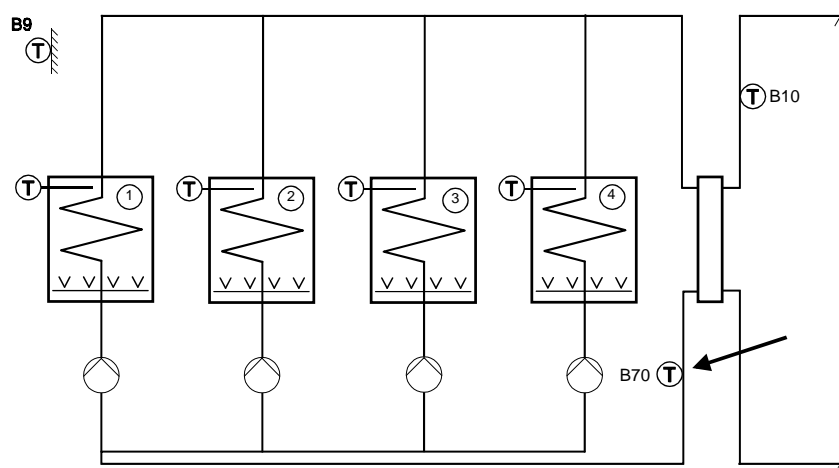

B70 Cascade return temperature sensor

### → Important

The meaning of the temperature measured at B70/B4 is defined by setting 1 (cascade return temperature sensor) on operating line 97.

### Special displays

|       |                                                                              |
|-------|------------------------------------------------------------------------------|
| -- -- | Sensor with open-circuit, no sensor connected, or sensor incorrectly defined |
| 0 0 0 | Sensor with a short-circuit                                                  |

## 4.8 Actual value of buffer storage tank temperature

| <b>Description</b>                                                                | When using alternative heat sources, the buffer storage tank temperature is used as a control criterion for the release of additional heat sources.                                                                         |                |             |         |    |
|-----------------------------------------------------------------------------------|-----------------------------------------------------------------------------------------------------------------------------------------------------------------------------------------------------------------------------|----------------|-------------|---------|----|
| <b>Setting</b>                                                                    | <ol style="list-style-type: none"> <li>1. Press the line selection buttons to select line 58.</li> <li>2. No setting can be made with the plus / minus buttons.</li> </ol>                                                  |                |             |         |    |
|  | <table border="1"> <thead> <tr> <th><i>Display</i></th> <th><i>Unit</i></th> </tr> </thead> <tbody> <tr> <td>0...140</td> <td>°C</td> </tr> </tbody> </table>                                                               | <i>Display</i> | <i>Unit</i> | 0...140 | °C |
| <i>Display</i>                                                                    | <i>Unit</i>                                                                                                                                                                                                                 |                |             |         |    |
| 0...140                                                                           | °C                                                                                                                                                                                                                          |                |             |         |    |
| <b>Effect</b>                                                                     | The actual temperature in the buffer storage tank (B4) will automatically be displayed on this line.                                                                                                                        |                |             |         |    |
| <b>Important</b>                                                                  | To be used as a buffer storage tank temperature sensor, input B70/B4 must be appropriately defined (operating line 97, setting 2)                                                                                           |                |             |         |    |
| → <b>Note</b>                                                                     | If input B70/B4 of the first cascade controller is already used by the optional cascade return temperature sensor B70, buffer storage tank temperature sensor B4 can be connected to input B70/B4 of the second controller. |                |             |         |    |

## 4.9 Actual value of d.h.w. temperature (TBWx)

| <b>Setting</b>                                                                      | <ol style="list-style-type: none"> <li>1. Press the line selection buttons to select line 59.</li> <li>2. No setting can be made with the plus / minus buttons.</li> </ol>                                                                      |                |                                                      |         |                             |
|-------------------------------------------------------------------------------------|-------------------------------------------------------------------------------------------------------------------------------------------------------------------------------------------------------------------------------------------------|----------------|------------------------------------------------------|---------|-----------------------------|
|  | <table border="1"> <thead> <tr> <th><i>Display</i></th> <th><i>Unit</i></th> </tr> </thead> <tbody> <tr> <td>0...140</td> <td>°C</td> </tr> </tbody> </table>                                                                                   | <i>Display</i> | <i>Unit</i>                                          | 0...140 | °C                          |
| <i>Display</i>                                                                      | <i>Unit</i>                                                                                                                                                                                                                                     |                |                                                      |         |                             |
| 0...140                                                                             | °C                                                                                                                                                                                                                                              |                |                                                      |         |                             |
| <b>Effect</b>                                                                       | The temperature measured with the d.h.w. temperature sensor (B3) connected to the controller, or the d.h.w. temperature transmitted by the BMU via PPS will automatically be displayed on this line.                                            |                |                                                      |         |                             |
| → <b>Note</b>                                                                       | Normally, with the type of d.h.w. demand "Thermostat" (line 125), no temperature will be displayed. The display shows " --- ". The input test (line 52, test step 1) provides information about the current switching status of the thermostat. |                |                                                      |         |                             |
| <b>Special displays</b>                                                             | <table border="1"> <tbody> <tr> <td>---</td> <td>Detector with an open-circuit or no sensor connected</td> </tr> <tr> <td>0 0 0</td> <td>Sensor with a short-circuit</td> </tr> </tbody> </table>                                               | ---            | Detector with an open-circuit or no sensor connected | 0 0 0   | Sensor with a short-circuit |
| ---                                                                                 | Detector with an open-circuit or no sensor connected                                                                                                                                                                                            |                |                                                      |         |                             |
| 0 0 0                                                                               | Sensor with a short-circuit                                                                                                                                                                                                                     |                |                                                      |         |                             |

## 4.10 Attenuated outside temperature

### Benefit

- Making use of the building's thermal storage capacity

### Description

The attenuated outside temperature is the simulated room temperature of a fictive building that has no internal heat source. This means that it is only the outside temperature that affects the room temperature.



### Setting

This operating line automatically displays the actual value [°C] of the attenuated outside temperature. No direct setting can be made.

The generation of the attenuated outside temperature cannot be influenced.

*Display* \_\_\_\_\_

*Unit* \_\_\_\_\_

-50...50

°C

### Resetting

It is possible, however, to reset the attenuated outside temperature:

1. Press the line selection buttons to select line 19.
2. Press the plus / minus buttons for 3 seconds.

As soon as the display stops flashing, the attenuated outside temperature is reset to the actual outside temperature.

### Process

The attenuated outside temperature is generated by the controller. It is continually calculated based on the prevailing outside temperature. The factory setting is 0 °C.

### Effect

The attenuated outside temperature affects directly only the summer / winter changeover (setting 16).

The attenuated outside temperature acts indirectly, via the composite outside temperature, on the flow temperature control.

### Example

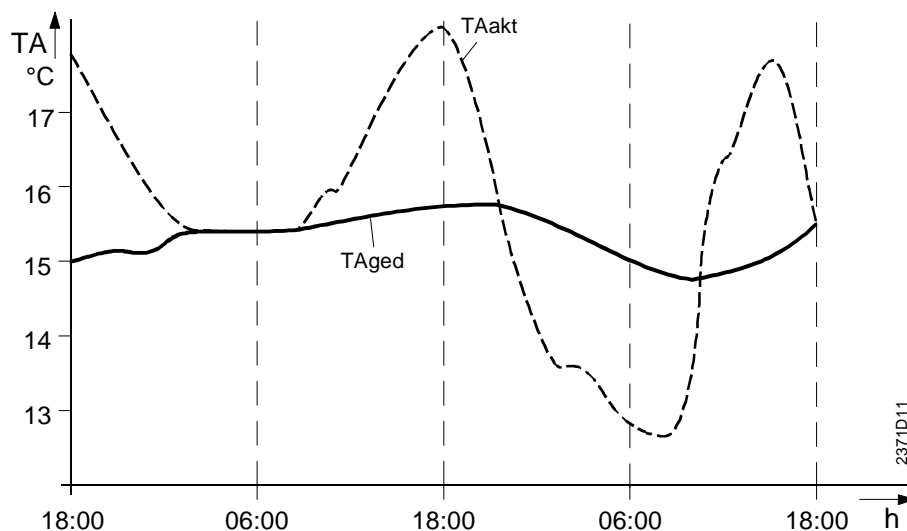

TAakt Actual outside temperature  
TAged Attenuated outside temperature

## 4.11 Composite outside temperature

### Benefit

- Compensating variable for the flow temperature control

### Description

The composite outside temperature is a mixture of the actual outside temperature and the attenuated outside temperature as calculated by the controller.

### Setting

This operating line automatically displays the actual value [°C] of the composite outside temperature. No direct setting can be made.



| Display  | Unit |
|----------|------|
| -50...50 | °C   |

### Process

The mixture of actual and attenuated outside temperature is dependent on the type of building construction (setting 105) and is generated as follows:

| Selected type of construction | Composite outside temperature                                     |
|-------------------------------|-------------------------------------------------------------------|
| Heavy (setting 105 = 0)       | $T_{A_{gem}} = \frac{1}{2} T_{A_{akt}} + \frac{1}{2} T_{A_{ged}}$ |
| Light (setting 105 = 1)       | $T_{A_{gem}} = \frac{3}{4} T_{A_{akt}} + \frac{1}{4} T_{A_{ged}}$ |

### Effect

The composite outside temperature as a compensating variable acts on the flow temperature control, that is thus matched to the prevailing weather conditions.

It also acts on the 24-hour heating limit to shut down the heating.

### Example

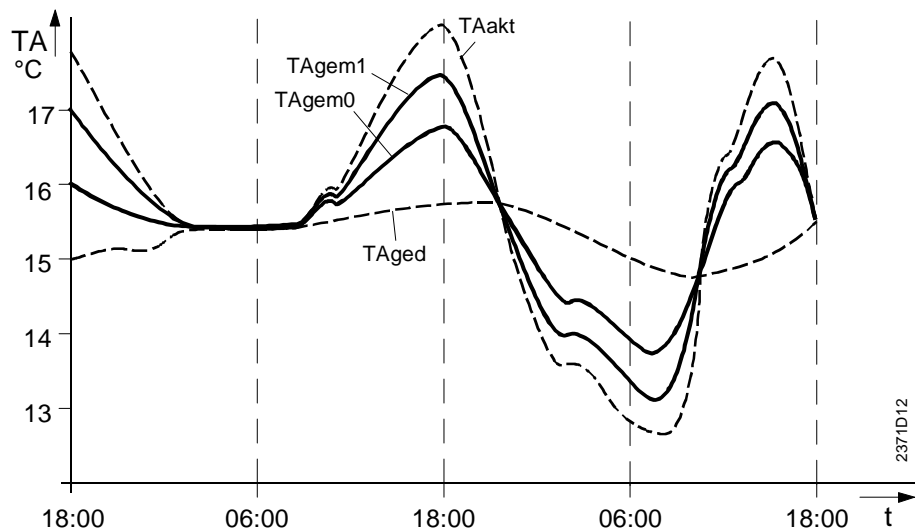

|                |                                                             |
|----------------|-------------------------------------------------------------|
| $T_{A_{akt}}$  | Actual outside temperature                                  |
| $T_{A_{ged}}$  | Attenuated outside temperature                              |
| $T_{A_{gem1}}$ | Composite outside temperature for light building structures |
| $T_{A_{gem0}}$ | Composite outside temperature for heavy building structures |

## 4.12 Outside temperature source

### Benefit

- Display and location of actual outside temperature measurement

### Description

When interconnecting several controllers, only one outside sensor is required. This sensor will be connected to any of the controllers and delivers its signal via LPB.

The controllers to which no sensor is connected adopt the outside temperature signal via the bus system, from a controller to which a sensor is connected.

### Setting

1. Press the line selection buttons to select line 62.
2. No setting can be made with the plus / minus buttons.



| <u>Display</u> | <u>Unit</u>                |
|----------------|----------------------------|
| --.---         | No signal                  |
| 00.01...14.16  | Segment and device address |

### Effect

The address of the outside detector that currently delivers the outside temperature signal will automatically be displayed on this line.

### Display

|        |                                                                                                                                                 |
|--------|-------------------------------------------------------------------------------------------------------------------------------------------------|
| --.--- | No outside sensor signal                                                                                                                        |
| 01.02  | Address of outside sensor<br>The first two digits represent the segment number (01.)<br>The second two digits represent the device number (.02) |

### → Note

If required (e.g. due to different exposure to solar radiation of the various buildings), the different sections of the system can be equipped with their own outside sensors. For more detailed information, refer to section "Outside temperature source" of "Local Process Bus (LPB), Basic Documentation, System Engineering" (document no. CE1P2370E).

## Setpoints

### 4.13 Setpoint of boiler temperature of BMUs

---

**Benefits**

- Indication of BMU temperature setpoints
- Better overview of the plant's operational status

---

**Description**

The lowest connected BMU number with the associated temperature setpoint will automatically be displayed on this line. The temperature setpoints of the other BMUs used in the cascade can be interrogated by pressing the plus / minus buttons. Non-existing BMUs will be skipped.

---

**Setting**

1. Press the line selection buttons to select line 65.
2. Press the plus / minus buttons to select the setpoint of the required BMU.

| <i>Display</i>  | <i>Unit</i>     |
|-----------------|-----------------|
| 1...4 / 0...140 | BMU number / °C |

**→ Note**

The setpoints can only be displayed but not changed. The function helps better understand the control sequences taking place in the controller.

No setpoint is displayed (---), when

- there is no heat demand from the consumers
- no BMU is connected to the controller

## 4.14 Setpoint of the cascade flow temperature

### Benefits

- Indication of setpoint of the cascade flow temperature
- Better overview of the plant's operational status

### Description

The setpoint of the cascade flow temperature will automatically be displayed on this line.

### Setting



1. Press the line selection buttons to select line 66.
2. No setting can be made with the plus / minus buttons.

| <i>Display</i> | <i>Unit</i> |
|----------------|-------------|
| 0...140        | °C          |

The setpoint can only be displayed but not changed. The function helps better understand the control sequences taking place in the controller.

### Generation of setpoint

The setpoint displayed is generated based on the different heat demand signals received from the system. These are:

- Demand for heat from the controller's internal heating circuits based on the outside temperature
- Demand for heat from the external heating circuits (system) based on the outside temperature
- Demand for heat for d.h.w. (from inside the controller or externally)
- Demand for heat via contact H1
- Demand for heat resulting from protective functions (e.g. frost protection for the plant)
- Demand for heat by pressing the button for manual operation

The highest of the setpoints received is shown on the display as the setpoint of the cascade flow temperature.

### → Note

The display shows "---", if one of the following points applies:

- There is no demand for heat
- The controller has been defined as a cascade controller (device address > 1)
- Sensor B10 has not been detected or connected

## 4.15 D.h.w temperature setpoint

### Benefits

- Indication of the d.h.w. temperature setpoint
- Better overview of the plant's operational status

### Description

The current d.h.w. temperature setpoint will automatically be displayed on this line.

### Setting



1. Press the line selection buttons to select line 69.
2. No setting can be made with the plus / minus buttons.

| <i>Display</i> | <i>Unit</i> |
|----------------|-------------|
| 0...140        | °C          |

The setpoint can only be displayed, but not changed.

### Generation of setpoint

The value displayed depends on the following parameters:

- Current time of day (operating line 1)
- Time switch program d.h.w. heating (lines 29...35)
- Setpoint of d.h.w. temperature (operating line 13)
- Reduced setpoint of d.h.w. temperature (operating line 120)
- Release of d.h.w. heating (operating line 121)
- Assignment of d.h.w. (operating line 123)
- d.h.w.frost protection (5°C)
- Number of d.h.w. heating cycles per day (operating line 124)
- Legionella function ON / OFF (operating line 42<sub>OEM</sub>)
- Legionella setpoint (operating line 43<sub>OEM</sub>)

### → Note

No value (---) is displayed in the following situations:

- No d.h.w. heating available
- D.h.w. heating is switched off (button for d.h.w. heating OFF)

## 4.16 Nominal room temperature setpoint

### Benefit

- Information about the nominal room temperature setpoint in normal operation

### Description

Displays the current nominal room temperature setpoint during the comfort period.

The nominal room temperature setpoint is the temperature adjusted on the controller that shall be maintained in the rooms in normal operation (comfort).

### Setting



1. Press the line selection buttons to select line 70.
2. No setting can be made with the plus / minus buttons.

| <i>Display</i> | <i>Unit</i> |
|----------------|-------------|
| 0.0...35.0     | °C          |

### Effect

The nominal room temperature setpoint will automatically be displayed on this line.

### Nominal room temperature setpoint

The resulting nominal room temperature setpoint is made up of the adjusted setpoint and a readjustment that may have been made on the room unit:

- Without a room unit

|   |                                                     |
|---|-----------------------------------------------------|
|   | Adjustment made with the controller's setpoint knob |
| = | controller's nominal room temperature setpoint      |

- When using a room unit with no programming facility (e.g. QAA50)

|   |                                                                |
|---|----------------------------------------------------------------|
|   | Adjustment made with the controller's setpoint knob            |
| + | readjustment made on the room unit ( $\pm 3$ °C) <sup>1)</sup> |
| = | controller's nominal room temperature setpoint                 |

- When using a room unit with a programming facility (e.g. QAA70)

|   |                                                                |
|---|----------------------------------------------------------------|
|   | Setpoint programmed with the room unit <sup>1)</sup>           |
| + | readjustment made on the room unit ( $\pm 3$ °C) <sup>1)</sup> |
| = | controller's nominal room temperature setpoint                 |

→ In that case, the controller's setpoint knob is inactive.

### → Important

- 1) Setpoints and readjustments made on room units are considered only in automatic mode .

## 4.17 Room temperature setpoint

### Benefit

- Information about the room temperature setpoint in the various operating modes

### Description

Displays the current room temperature setpoint during the respective heating period (normal operation / reduced operation).

### Setting



1. Press the line selection buttons to select line 71.
2. No setting can be made with the plus / minus buttons.

| <i>Display</i> | <i>Unit</i> |
|----------------|-------------|
| 0...35         | °C          |

When selecting the operating line, the current room temperature setpoint is displayed, depending on the operating mode and the time switch program, that is, a selection / combination of the following parameters:

- Room temperature setpoint knob
- Reduced setpoint of room temperature (line 13)
- Frost protection setpoint of room temperature (line 15)
- Readjustments made on the room unit (QAA50 / QAA 70)

### → Note

If there is no heating circuit, the display shows “---”.

## 4.18 Flow temperature setpoint

### Benefit

- Displays the current flow temperature setpoint of the pump heating circuit

### Description

When selecting this operating line, the current flow temperature setpoint of the controller's internal pump heating circuit is displayed.

### Setting

1. Press the line selection buttons to select line 72.
2. No setting can be made with the plus / minus buttons.



| <i>Display</i> | <i>Unit</i> |
|----------------|-------------|
| 0...140        | °C          |

The value displayed corresponds to the flow temperature of the pump heating circuit which is required for reducing the demand for heat.

### → Note

The display shows “---“ in the following situations:

- No heating circuit available
- ECO function active (summer / winter changeover, automatic daily heating limit)
- Quick setback active
- Room temperature limitation active

## Heat generation values

### 4.19 Existing boilers

#### Benefit

- Overview of the boilers used by the system

#### Description

The function makes it possible to obtain a quick overview of the boilers used by the system.

#### Setting



1. Press the line selection buttons to select line 75.
2. Press the plus / minus buttons to scroll through the list of available boilers.

| <u>Display</u> | <u>Unit</u> |
|----------------|-------------|
| 00.1...16.3    | -           |

The numbers have the following meaning:

00.1...16.3    Device addresses and device subaddresses (boiler number in a controller) of the boilers assigned to the system (max. 16).  
All boilers must be contained in segment 0 to ensure the demand for heat from all segments will be considered.

#### → Caution!

Do not mix up device / device subaddress with segment / device address!  
If the segment address was added, the display would read 0.00.1 ... 0.16.3.

#### Device address

A controller that uses device address 0 (e.g. **00.1**) operates autonomously (no communication via LPB).

The device address 1 (**01.1**) defines the cascade master (controller).

#### Device subaddress

Up to four BMUs can be connected to the first RVA47.320 (B-series) of a cascade, and up to three BMUs to each of the additional RVA47.320 (B-series).

The possible device subaddresses are therefore 1.1 ... 1.4, 2.1 ... 2.3, 3.1 ... 3.3 to 16,3 One cascade can contain a maximum of 16 boilers, however.

For more detailed information, refer to "Local Process Bus (LPB), Basic Documentation, System Engineering" (document no. CE1P2370E).

## 4.20 Display lead boiler

### Benefit

- Quick overview of current lead boiler

### Description

With “Automatic lead boiler changeover”, this function facilitates quick detection of the lead boiler.

### Display

When selecting this operating line, the current lead boiler is displayed. No settings can be made with the plus / minus buttons.



| <i>Display</i> | <i>Unit</i> |
|----------------|-------------|
| 00.1...16.3    | -           |

The numbers have the following meaning:

00.1...16.3    Device address and device subaddress (boiler number in a controller) of the boilers assigned to the system (max. 16).  
All boilers must be contained in segment 0 to ensure the demand for heat from all segments will be considered.

### → Caution

Do not mix up device / device subaddress and segment / device address!  
If the segment address was added, the display would read 0.00.1 ... 0.16.3.

### Device address

A controller that uses device address 0 (e.g. **00.1**) operates autonomously ( no communication via LPB).

The device address 1 (**01.1**) defines the cascade master (controller).

### Device subaddress

Up to four BMUs can be connected to the first RVA47.320 (B-series) of a cascade, and up to three BMUs to each of the additional RVA47.320 (B-series).

The possible device subaddresses are therefore 1.1 ... 1.4, 2.1 ... 2.3, 3.1 ... 3.3 through 16.3 One cascade can contain a maximum of 16 boilers, however.

### → Note

The setting for boiler sequence changeover is made on operating line 130.  
For more detailed information, refer to “Local Process Bus (LPB), Basic Documentation, System Engineering“ (document no. CE1P2370E).

## 4.21 Remaining number of operating hours for changeover of boiler sequence

| <b>Benefit</b>                                                                    | <ul style="list-style-type: none"> <li>Indication of the remaining number of operating hours until the next changeover of boiler sequence takes place.</li> </ul>                                                                                                                                      |                |             |               |       |
|-----------------------------------------------------------------------------------|--------------------------------------------------------------------------------------------------------------------------------------------------------------------------------------------------------------------------------------------------------------------------------------------------------|----------------|-------------|---------------|-------|
| <b>Description</b>                                                                | Indicates the number of hours the current lead boiler still operates until the next changeover of boiler sequence occurs.                                                                                                                                                                              |                |             |               |       |
| <b>Setting</b>                                                                    | When selecting this operating line, the remaining number of operating hours for changeover of the boiler sequence are displayed.                                                                                                                                                                       |                |             |               |       |
|  | <table border="1"> <thead> <tr> <th><i>Display</i></th> <th><i>Unit</i></th> </tr> </thead> <tbody> <tr> <td>0...990 / ---</td> <td>h / -</td> </tr> </tbody> </table>                                                                                                                                 | <i>Display</i> | <i>Unit</i> | 0...990 / --- | h / - |
| <i>Display</i>                                                                    | <i>Unit</i>                                                                                                                                                                                                                                                                                            |                |             |               |       |
| 0...990 / ---                                                                     | h / -                                                                                                                                                                                                                                                                                                  |                |             |               |       |
| <b>Display</b>                                                                    | The number displayed represents the number of operating hours until the next changeover of boiler sequence occurs. It is generated by subtracting the current number of operating hours from the setting made on operating line 130 (automatic changeover according to the number of operating hours). |                |             |               |       |
| → <b>Note</b>                                                                     | The display appears only if, on operating line 130, a setting of 10...990h has been selected (automatic changeover according to the number of operating hours). Otherwise, the display will show "- - -".                                                                                              |                |             |               |       |

## 4.22 Burner operating hours BMU 1 – 4

| <b>Benefits</b>                                                                     | <ul style="list-style-type: none"> <li>Overview of the number of burner operating hours of the individual BMUs</li> </ul> <p>Criterion for service and maintenance work</p> <p>Criterion for adjusting the cascade management strategy</p>                                                                                                                                                                                                                                                                                                                                             |                |             |           |   |         |                                           |         |                                           |         |                                           |         |                                           |
|-------------------------------------------------------------------------------------|----------------------------------------------------------------------------------------------------------------------------------------------------------------------------------------------------------------------------------------------------------------------------------------------------------------------------------------------------------------------------------------------------------------------------------------------------------------------------------------------------------------------------------------------------------------------------------------|----------------|-------------|-----------|---|---------|-------------------------------------------|---------|-------------------------------------------|---------|-------------------------------------------|---------|-------------------------------------------|
| <b>Description</b>                                                                  | The display shows the number of hours the respective BMU has been operating since the controller was first commissioned.                                                                                                                                                                                                                                                                                                                                                                                                                                                               |                |             |           |   |         |                                           |         |                                           |         |                                           |         |                                           |
| <b>Setting</b>                                                                      | <ol style="list-style-type: none"> <li>Press the line selection buttons to select lines 80 -83.</li> <li>No settings can be made with the plus / minus buttons.</li> </ol>                                                                                                                                                                                                                                                                                                                                                                                                             |                |             |           |   |         |                                           |         |                                           |         |                                           |         |                                           |
|  | <table border="1"> <thead> <tr> <th><i>Display</i></th> <th><i>Unit</i></th> </tr> </thead> <tbody> <tr> <td>0...65535</td> <td>h</td> </tr> </tbody> </table> <p>The numbers have the following meaning:</p> <table border="1"> <tbody> <tr> <td>Line 80</td> <td>Number of burner operating hours of BMU 1</td> </tr> <tr> <td>Line 81</td> <td>Number of burner operating hours of BMU 2</td> </tr> <tr> <td>Line 82</td> <td>Number of burner operating hours of BMU 3</td> </tr> <tr> <td>Line 83</td> <td>Number of burner operating hours of BMU 4</td> </tr> </tbody> </table> | <i>Display</i> | <i>Unit</i> | 0...65535 | h | Line 80 | Number of burner operating hours of BMU 1 | Line 81 | Number of burner operating hours of BMU 2 | Line 82 | Number of burner operating hours of BMU 3 | Line 83 | Number of burner operating hours of BMU 4 |
| <i>Display</i>                                                                      | <i>Unit</i>                                                                                                                                                                                                                                                                                                                                                                                                                                                                                                                                                                            |                |             |           |   |         |                                           |         |                                           |         |                                           |         |                                           |
| 0...65535                                                                           | h                                                                                                                                                                                                                                                                                                                                                                                                                                                                                                                                                                                      |                |             |           |   |         |                                           |         |                                           |         |                                           |         |                                           |
| Line 80                                                                             | Number of burner operating hours of BMU 1                                                                                                                                                                                                                                                                                                                                                                                                                                                                                                                                              |                |             |           |   |         |                                           |         |                                           |         |                                           |         |                                           |
| Line 81                                                                             | Number of burner operating hours of BMU 2                                                                                                                                                                                                                                                                                                                                                                                                                                                                                                                                              |                |             |           |   |         |                                           |         |                                           |         |                                           |         |                                           |
| Line 82                                                                             | Number of burner operating hours of BMU 3                                                                                                                                                                                                                                                                                                                                                                                                                                                                                                                                              |                |             |           |   |         |                                           |         |                                           |         |                                           |         |                                           |
| Line 83                                                                             | Number of burner operating hours of BMU 4                                                                                                                                                                                                                                                                                                                                                                                                                                                                                                                                              |                |             |           |   |         |                                           |         |                                           |         |                                           |         |                                           |
| → <b>Note</b>                                                                       | For information about the selection of the cascade management strategy, refer to operating lines 50 <sub>OEM</sub> to 52 <sub>OEM</sub> .                                                                                                                                                                                                                                                                                                                                                                                                                                              |                |             |           |   |         |                                           |         |                                           |         |                                           |         |                                           |

## 4.23 Minimum limitation of boiler temperature

### TKmin

#### Benefit

- This function prevents the boiler temperature from falling below a predefined minimum temperature.

#### Description

Minimum limitation of the boiler temperature setpoint is a protective function for the boiler. In addition, minimum limitation of the setting range can be provided with the setting 01<sub>OEM</sub>.

#### Setting

90

- Press the line selection buttons to select line 90.
- Press the plus / minus buttons to set the minimum limitation of the boiler temperature TKmin.

| Setting range                            | Unit | Factory setting |
|------------------------------------------|------|-----------------|
| TKmin <sub>OEM</sub> ...TKmax (max 95°C) | °C   | 8               |

TKmin<sub>OEM</sub> Minimum limitation of the boiler temperature setpoint (setting on line 01<sub>OEM</sub>)  
 TKmax Maximum limitation of the boiler temperature setpoint (setting on line 02<sub>OEM</sub>)

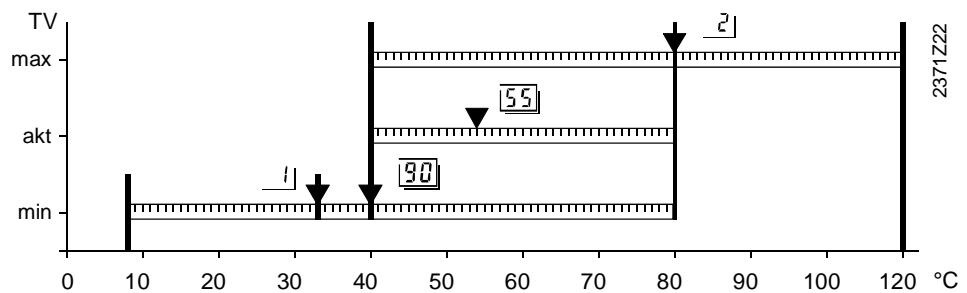

55 Actual value of boiler temperature  
 90 Minimum limitation of the boiler temperature setpoint  
 2<sub>OEM</sub> Maximum limitation of the boiler temperature setpoint  
 1<sub>OEM</sub> Lowest minimum limitation of the boiler temperature setpoint

#### Effect

If the boiler temperature falls below the set minimum temperature, this setting generates a locking signal which reduces the amount of heat supplied to the consumers.

## 4.24 Nominal output of BMU 1 - 4

### Benefit

- Consideration is given to the different heat source capacities

### Description

By setting this parameter, the controller knows the proportion of capacities of the connected boilers and can take this into account with the running time strategy and the linked lead boiler operation (refer to page 129 ff.).

### Settings



1. Press the line selection buttons to select lines 91 -94.
2. Press the plus / minus buttons to set the nominal capacities of BMUs 1 - 4.

| Line | BMU-Nr. | Setting range | Unit | Factory setting |
|------|---------|---------------|------|-----------------|
| 91   | BMU1    | 0...255       | kW   | 20              |
| 92   | BMU2    | 0...255       | kW   | 20              |
| 93   | BMU3    | 0...255       | kW   | 20              |
| 94   | BMU4    | 0...255       | kW   | 20              |

### → Note

The controller only uses the proportions of the numbers entered. When having capacities of 100 / 150 / 70 kW, entry of the proportions of 10 / 15 / 7 or 20 / 30 / 14 will lead to the same result as entry of the absolute figures. Hence, capacities above 255 kW can also be entered by using the respective ratios.

### Effect

This setting has an impact on the accuracy of the points in time the individual boilers are switched on and off (refer to boiler management and running time strategy, operating line 50<sub>OEM</sub>).

#### **Autonomous lead boiler operation:**

No effect

#### **Linked lead boiler operation:**

The lag boilers follow the lead boiler's output at different speeds, depending on the proportion of capacities of lead boiler and lag boilers.

#### **Running time strategy 1 - 3:**

Additional boilers are switched on or off earlier or later, depending on the capacities of the individual boilers in sequence.

## Configuration of plant

### 4.25 Pump function output Q1

---

**Benefit**

- Use of pump for different types of plant

---

**Description**

This parameter defines the function provided by the pump connected to terminal Q1.

**→ Note**

Setting of this function has an impact on the automatic generation of the type of plant. Operating line 53.

---

**Setting**

1. Press the line selection buttons to select line 95.
2. Press the plus / minus buttons to select the required function of the circulating pump.

---

| <i>Setting range</i> | <i>Unit</i> | <i>Factory setting</i> |
|----------------------|-------------|------------------------|
| 1...5                | -           | 1                      |

---

**Effect**

The pump provides one of the following functions, depending on the setting made:

- 1 Circulating pump operates as a heating circuit pump of the controller-internal pump heating circuit or no pump is available.
- 2 Circulating pump works as a primary pump for the heating circuits only (located after the d.h.w. storage tank).
- 3 Circulating pump works as a primary pump for the heating circuits and for the d.h.w. (located before the d.h.w. storage tank).
- 4 Circulating pump operates as a d.h.w. circulating pump
- 5 Circulating pump operates as an H1 pump

Pump overrun is active with all settings, with the exception of setting 4.

## 4.26 Use of sensor input B70/B4

### Benefit

- The same sensor input can be used for different functions

### Description

This parameter setting defines the function adopted by the temperature sensor connected to terminal B70/B4.

### Setting

97

1. Press the line selection buttons to select line 97.
2. Press the plus / minus buttons to select the required function of the input B70/B4.

| <i>Setting range</i> | <i>Unit</i> | <i>Factory setting</i> |
|----------------------|-------------|------------------------|
| 1...2                | -           | 1                      |

### Effect

Depending on the setting made, the sensor provides the following function:

- 1 The sensor is used for measuring the return temperature (B70).
- 2 The sensor is used for measuring the buffer storage tank temperature (B4).

### Use in cascades

If, with the first controller, sensor input B70/B4 is defined for use with a return temperature sensor (B70), for instance, it can be defined with another controller of the cascade for use with a buffer storage tank temperature sensor (B4). The sensor values are automatically transmitted to the cascade master. Within a cascade, each type of sensor may occur only once.

### Use as a buffer storage tank temperature sensor

When using input B70/B4 for a buffer storage tank temperature sensor (B4), the temperature measured at B4 is used to decide whether the consumers receive their heat from the cascade or from the buffer storage tank.

If the temperature measured in the buffer storage tank is higher than the flow temperature called for by the consumers, the cascade will be locked and the consumers receive their heat from the buffer storage tank.

If the temperature measured in the buffer storage tank is lower than the flow temperature called for by the consumers, the buffer storage tank will be locked and the consumers receive their heat solely from the cascade.

**Example**

Example of a hydraulic circuit with a buffer storage tank. The buffer storage tank can be charged by any type of heat source (wood-fired boiler, solar collectors, heat pump, etc).

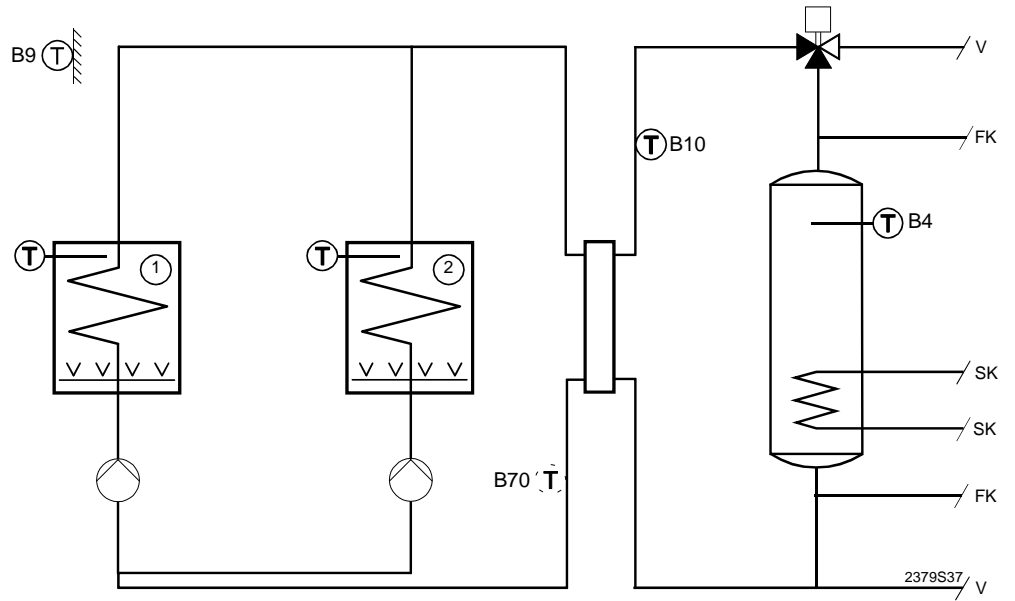

- SK = solar collectors
- FK = solid fuel boiler
- V = consumer

**Connection of changeover valve**

The changeover valve must be connected in parallel to the pump of the first BMU. This BMU must be excluded from automatic changeover of the boiler sequence (refer to operating line 131).

# Space heating

## 4.27 Parallel displacement of heating curve

**Benefit**

- Adjustment of controller's temperature scale to the actual plant conditions.

**Description**

Produces a parallel displacement of the heating curve in order to achieve a better match of room temperature setpoints and actual room temperatures.

**Setting**



1. Press the line selection buttons to select line 100.
2. Press the plus / minus buttons to set the parallel displacement.

| Setting range | Unit   | Factory setting |
|---------------|--------|-----------------|
| -4.5...+4.5   | °C (K) | 0.0             |

**Effect**

By changing the value entered, all room temperature setpoints will be appropriately raised or lowered, allowing the room temperature setpoints to be matched to the effective room temperatures.

**Example:**

If a nominal room temperature setpoint of 20 °C adjusted on the controller always produces a room temperature of 22 °C (independent of the prevailing outside temperature), displace the heating curve downward by 2 °C.

**parallel displacement**

Each setpoint readjustment, be it by changing the setting value or the operational level, corresponds to a parallel displacement of the heating curve.

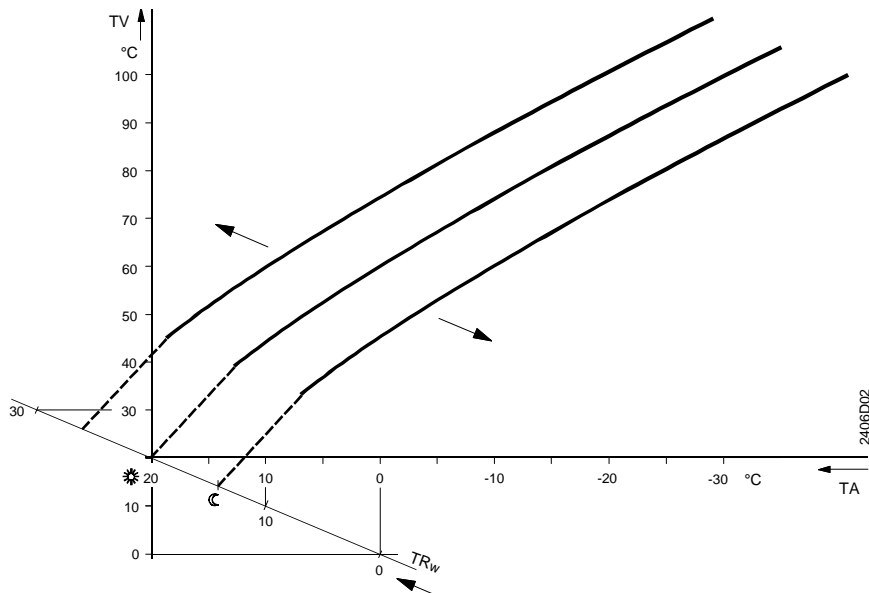

- TV Flow temperature
- TA Composite outside temperature
- TRw Room temperature setpoint

## 4.28 Gain factor for room temperature influence

### Benefits

- More accurate room temperature control due to temperature checkback signal from the space
- Use of heat gains
- Possibility of boost heating and quick setback

### Description

Defines the impact of room temperature deviations on the controlled system.

Room temperature deviation is the temperature differential between actual room temperature and room temperature setpoint.

### Setting



1. Press the line selection buttons to select line 101.
2. Press the plus / minus buttons to select the gain factor for the room temperature influence.

| <u>Setting range</u> | <u>Unit</u> | <u>Factory setting</u> |
|----------------------|-------------|------------------------|
| 0 / 1                | Increment   | 1                      |

### Effect

The setting will activate or deactivate the effect of room temperature deviations on the temperature control.

Entry:

- 0: Room temperature influence inactive: The measured room temperature will not affect the temperature control
- 1: Room temperature influence active: The measured room temperature will affect the temperature control

### Gain factor for room temperature influence

Room temperature influence means:

Deviations of the actual room temperature from the setpoint are acquired and taken into account by the temperature control.

To use the control variant "Weather compensation with room temperature influence", the following conditions must be satisfied:

- **An outside sensor** must be connected (either to B9, the PPS or the LPB).
- Setting "Room temperature influence" (101) **must** be active (1)
- The respective room unit **must** be connected to terminal A6 (PPS)
- There may be **no controlled thermostatic radiator valves** (If such valves are present, they must be set to their fully open position).

## 4.29 Switching differential of room temperature

### Benefits

- Temperature control with pump heating circuit
- Prevents overtemperatures in the room in the case of pump heating circuits

### Description

Serves as a room temperature limitation with pump heating circuits

### Setting

1. Press the line selection buttons to select line 102.
2. Press the plus / minus buttons to set the room temperature switching differential.



| Setting range       | Unit    | Factory setting |
|---------------------|---------|-----------------|
| -- . -<br>0.5...4.0 | -<br>°C | -- . -          |

### Effect

The switching differential for two-position control will be changed.

Entry:

- . - Switching differential is inactive
- The pump always remains activated.

- Decrease: Switching differential will become smaller
- Pumps are switched on and off **more often**
  - Room temperature varies within a **narrower** band

- Increase: Switching differential will become greater
- Pumps are switched on and off **less often**
  - Room temperature varies within a **wider** band

### Room temperature control

With pump heating circuits, the amount of heat supplied is controlled by switching the pumps on and off. This is accomplished with two-position control by means of the room temperature's switching differential.

### → Note

Room temperature acquisition requires a room unit.

### Functioning:



### Legende

- TRx Actual room temperature
- TRw Room temperature setpoint
- SDR Switching differential of room temperature
- ON Switch-on point
- OFF Switch-off point
- t Time
- P Pump

Switching differential

|          |                     |
|----------|---------------------|
| Pump ON  | $TR_x = TR_w$       |
| Pump OFF | $TR_x = TR_w + SDR$ |

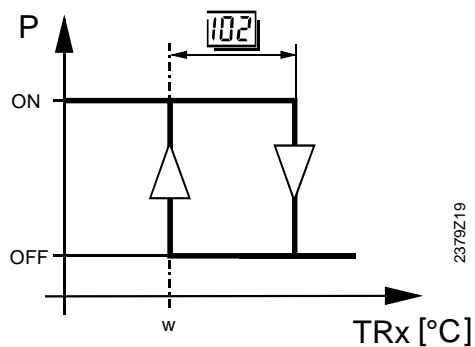

- TRx Actual room temperature
- TRw Room temperature setpoint
- SDR Switching differential of room temperature
- P Pump (ON / OFF)
- w Setpoint
- △ Switch-on point
- ▽ Switch-off point

## 4.30 Minimum limitation of flow temperature setpoint

### Benefit

- Prevents too low flow temperatures

### Description

Minimum and maximum limitation define the range within which the flow temperature setpoint may vary.

### Setting

103

1. Press the line selection buttons to select line 103.
2. Press the plus / minus buttons to set the minimum limitation of the flow temperature setpoint.

| <i>Einst ellbereich</i> | <i>Unit</i>                                                           | <i>Factory setting</i> |
|-------------------------|-----------------------------------------------------------------------|------------------------|
| 8...TVmax               | °C                                                                    | 8                      |
| TVmax                   | Maximum limitation of flow temperature setpoint (setting on line 104) |                        |

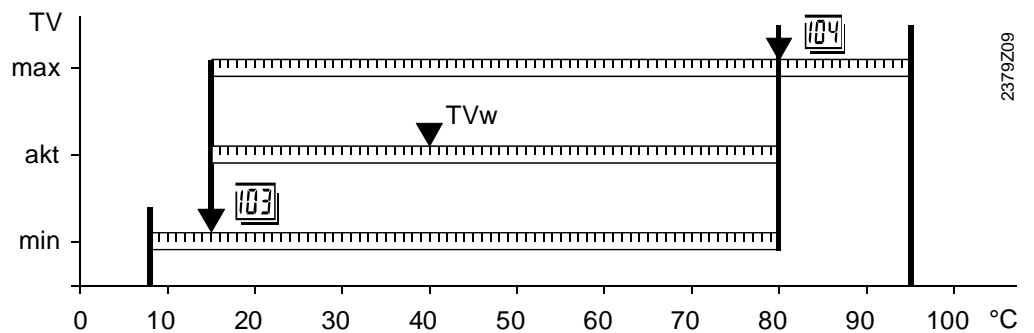

|     |                                                 |
|-----|-------------------------------------------------|
| TVw | Current flow temperature setpoint               |
| 103 | Minimum limitation of flow temperature setpoint |
| 104 | Maximum limitation of flow temperature setpoint |

### Effect

The setting will make certain that the flow temperature setpoint will not fall below a minimum level.

### Limitation

If the flow temperature setpoint demanded by the heating circuit reaches the minimum limit and the outside temperature rises, the flow temperature setpoint will be maintained at that limit, in other words, it will not be allowed to fall below it.

## 4.31 Maximum limitation of flow temperature setpoint

### Benefit

- Prevents too high flow temperatures

### Description

Minimum and maximum limitation define the range within which the flow temperature setpoint may vary.

### Setting

104

1. Press the line selection buttons to select line 104.
2. Press the plus / minus buttons to set the maximum limitation of the flow temperature setpoint.

| <i>Setting range</i> | <i>Unit</i>                                                           | <i>Factory setting</i> |
|----------------------|-----------------------------------------------------------------------|------------------------|
| TVmin...95           | °C                                                                    | 80                     |
| TVmin                | Minimum limitation of flow temperature setpoint (setting on line 103) |                        |

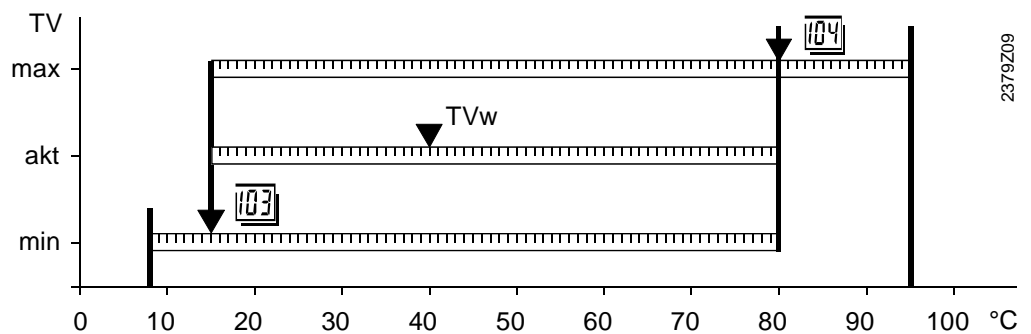

TVw Current flow temperature setpoint  
 103 Minimum limitation of flow temperature setpoint  
 104 Maximum limitation of flow temperature setpoint

### Effect

The setting will ensure that the flow temperature setpoint will not exceed a maximum level.

### → Important

Maximum limitation is **not** to be regarded as a safety function as required with underfloor heating systems, for example.

### Limitation

If the flow temperature setpoint demanded by a consumer reaches the maximum limit and the outside temperature falls, the flow temperature setpoint will be maintained at that limit, in other words, it will not be allowed to exceed it.

## 4.32 Type of building construction

### Benefit

- Consideration is given to the building's thermal dynamics

### Description

Enables the control system's response to be matched to the type of building construction.

### Setting

105

1. Press the line selection buttons to select line 105.
2. Press the plus / minus buttons to select the type of building construction.

| <u>Setting range</u> | <u>Unit</u> | <u>Factory setting</u> |
|----------------------|-------------|------------------------|
| 0 / 1                | Increment   | 1                      |

### Effect

When the outside temperature varies, the room temperature changes at different rates, depending on the building's thermal storage capacity.

The above setting ensures that the generation of the composite outside temperature will be matched to the type of building construction. Also refer to "Composite outside temperature" in section "Functions without settings".

Entry:

- 0: Heavy building structures: The room temperature will respond *slower* to outside temperature variations
- 1: Light building structures: The room temperature will respond *quicker* to outside temperature variations

### Building construction

- Heavy building structures:  
Buildings with thick walls or with external insulation.
- Light building structures:  
Buildings with a light envelope.

## 4.33 Adaptation of heating curve

### Benefits

- No heating curve adjustments required
- Automatic adaptation of heating curve

### Description

The adaptation facility learns from the different heating situations and matches the control to the heating circuit at regular. Also refer to section "Adaptation sensitivities" (lines 36<sub>OEM</sub> + 37<sub>OEM</sub>).

### Setting

106

1. Press the line selection buttons to select line 106.
2. Press the plus / minus buttons to select the type of heating curve adaptation.

| <u>Setting range</u> | <u>Unit</u> | <u>Factory setting</u> |
|----------------------|-------------|------------------------|
| 0 / 1                | Increment   | 1                      |

### Effect

The setting will switch automatic adaptation of the heating curve on or off.

Entry:

- 0: Automatic adaptation *inactive*: The heating curve will use the setting made
- 1: Automatic adaptation *active*: In automatic mode (nominal room temperature setpoint), the heating curve will automatically and continuously be adapted

### → Note

Prerequisite is the presence of a room temperature detector.

### Adaptation

The adaptation facility automatically matches the heating curve to the type of building construction and the heating requirements. Adaptation gives consideration to room temperature deviations, outside temperature characteristics and adaptation sensitivity.

### → Note

To achieve an optimum adaptation, the following situations should occur as rarely as possible - especially after commissioning - since this would reset certain calculations required for the adaptation:

- Manual correction of heating curve
- Power failure
- Heating curve set to --.-
- Changes to the room temperature setpoint

### Process

Every day at midnight, the room temperature control differential of the previous day is evaluated. This evaluation leads to an automatic readjustment of the heating curve.

- Simple adaptation (range ):  
At attenuated outside temperatures below 4 °C, it is only the slope of the heating curve that is adapted.

Within this temperature range, the readjustment is weighted with the factor f2 and the adaptation sensitivity 2 (line 37<sub>OEM</sub>).

- Combined adaptation (range ):  
At attenuated outside temperatures of between 4 and 12 °C, it is partly the slope and partly the parallel displacement which are adapted.

Within this temperature range, the readjustment of the parallel displacement is weighted with the factor f1 and the adaptation sensitivity 1 (line 36<sub>OEM</sub>).

The readjustment of the slope in this temperature range is weighed with factor  $f_2$  and adaptation sensitivity 2 (line 37<sub>OEM</sub>).

- No adaptation (range ):  
At attenuated outside temperatures above 12 °C, the heating curve will not be adapted.

## Diagram

Example using a nominal room temperature setpoint of 20 °C.

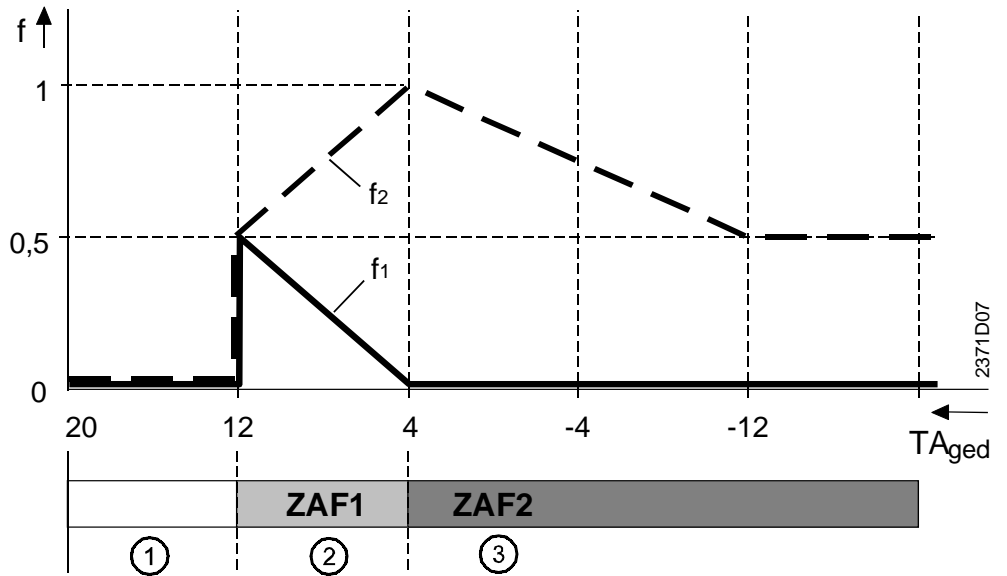

|       |                                                    |
|-------|----------------------------------------------------|
| f     | Factor                                             |
| f1    | Factor for parallel displacement                   |
| f2    | Factor for slope                                   |
| TAged | Attenuated outside temperature                     |
| ZAF1  | Adaptation sensitivity 1 (line 36 <sub>OEM</sub> ) |
| ZAF2  | Adaptation sensitivity 2 (line 37 <sub>OEM</sub> ) |

## D.h.w. values

### 4.34 Reduced setpoint of d.h.w. temperature

#### Benefits

- High d.h.w. temperatures only if required.
- Energy savings due to lower temperatures in the remaining time.

#### Description

Reduction of d.h.w. temperatures outside main occupancy times.  
The time switch integrated in the controller automatically switches between main and secondary occupancy times. For more detailed information, refer to "D.h.w. heating program", operating lines 29...35

#### → Note

If the d.h.w. is heated by means of a control thermostat connected to terminal B3, reduced setpoint operation will not be possible.

#### Setting



1. Press the line selection buttons to select line 120.
2. Press the plus / minus buttons to adjust the reduced setpoint of the d.h.w. temperature.

| Setting range | Unit | Factory setting |
|---------------|------|-----------------|
| 8...TBWw      | °C   | 40              |

TBWwNominal setpoint of d.h.w. temperature (setting on line 13)

#### Effect

The temperature setpoint during reduced d.h.w. operation will be changed.

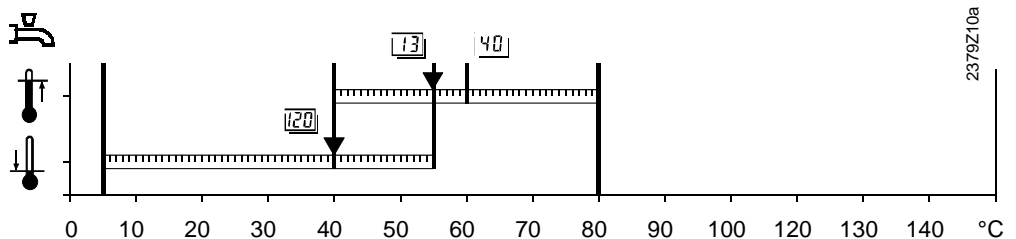

- 13 Setting "Nominal setpoint of d.h.w. temperature"  
120 Setting "Reduced setpoint of d.h.w. temperature"  
40<sub>OEM</sub> Setting "Maximum nominal setpoint of d.h.w. temperature"

#### D.h.w. temperature setpoints



- Nominal setpoint of d.h.w. temperature (setting on line 13)  
Produces the d.h.w. temperature required during main occupancy times.
- Reduced setpoint of d.h.w. temperature (setting on line 120)  
Produces the d.h.w. temperature required outside the main occupancy times.

The periods of time during which these d.h.w. temperature setpoints shall be used can be set on line 121.

## 4.35 Release of d.h.w. heating

### Benefits

- Release of d.h.w. heating at nominal setpoint as demanded by the consumers
- Release of d.h.w. heating can be matched to the plant's load curve

### Description

Makes it possible to limit the period of time during which d.h.w. heating at the nominal setpoint is released.

### Setting



1. Press the line selection buttons to select line 121.
2. Press the plus / minus buttons to enter the required period of time during which d.h.w. heating at the nominal setpoint shall be released.

| <i>Setting range</i> | <i>Unit</i> | <i>Factory setting</i> |
|----------------------|-------------|------------------------|
| 0...2                | Increment   | 1                      |

### Effect

The setting defines the period of time during which d.h.w. heating at the nominal setpoint is released. Outside this period of time, the reduced d.h.w. setpoint applies, with one exception, the function "D.h.w. push" (function without setting. Einzige Ausnahme ist die Funktion „Brauchwasser-Push“ (Funktion ohne Einstellung).

Release of d.h.w. heating at the nominal setpoint takes place when using the following settings:

- 0 24 hours per day
- 1 According to the heating circuit time switch program(s) with forward shift
- 2 According to the d.h.w. time switch program of the RVA47.320

### → Note

The frost protection temperature for d.h.w. is fixed at 5 °C and is always active. The function runs independent of the selected heating circuit operating mode.

### 4.35.1 24-hour operation

#### **Setting 0**

The d.h.w. temperature is always maintained at the nominal d.h.w. temperature setpoint, independent of any time switch programs (setting line 13).

Example:

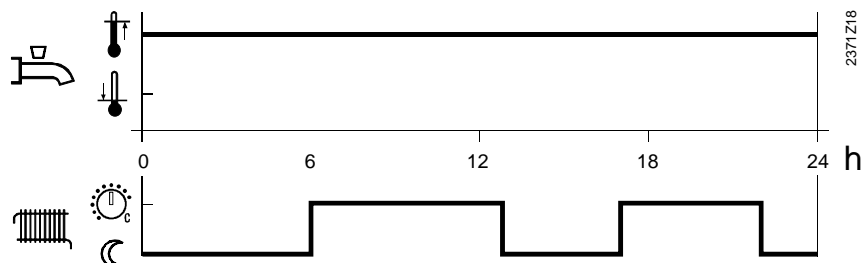

## 4.35.2 Operation according to heating program(s) with forward shift

### Setting 1

For d.h.w. heating, the heating circuit time switch programs of the controllers in the selected range are taken into consideration. The selection of the range (local / segment / system) for which the d.h.w. is produced is made on operating line 123.

The switch-on point for the release is shifted forward in time against the earliest switch-on point of all heating circuits. The switch-off point for the release coincides with the last switch-off point of all heating circuits.

At the switch-on point, the controller switches from the reduced d.h.w. temperature setpoint (setting line 120) to the nominal d.h.w. temperature setpoint (setting line 13). At the switch-off point, the controller switches from the nominal to the reduced d.h.w. temperature setpoint.

→ Note

The extent to which the switch-on point is shifted forward in time depends on the number of d.h.w. heating cycles permitted in a 24-hour period (setting line 124):

Example:

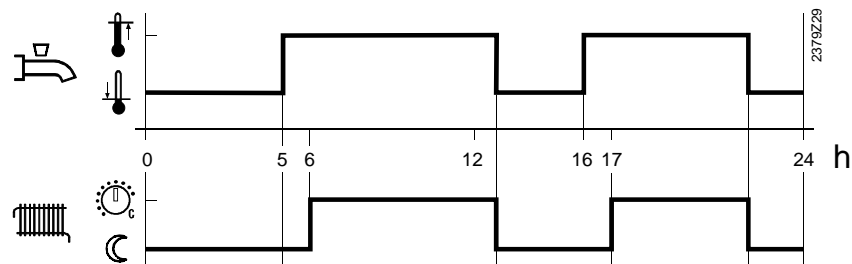

## 4.35.3 Operation according to d.h.w. time switch program

### Setting 2

For d.h.w. heating, time switch program (d.h.w.) of the local controller is taken into account. The set switching times of that program are then used to change over between the nominal d.h.w. setpoint (setting line 13) and the reduced d.h.w. setpoint (setting line 120).

D.h.w. heating takes place independent of the heating circuit programs.

Heating periods

With this d.h.w. heating program, it is possible to have a maximum of three heating periods per day. The forward shift of the switch-on times is inactive.

Example:

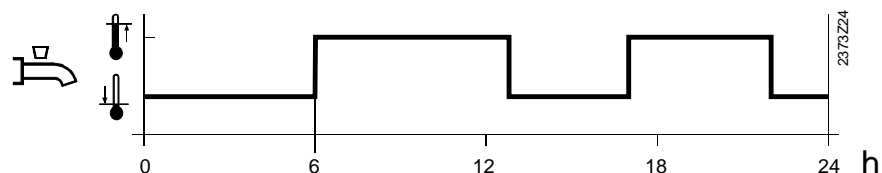

## 4.36 Switching program for circulating pump

### Benefits

- The circulating pump runs only during the selected periods of time
- No heat losses during the periods of time when there is no demand for d.h.w.

### Description

Defines the time switch program according to which the circulating pump is switched on and off.

### Setting



1. Press the line selection buttons to select line 122.
2. Press the plus / minus buttons to select the required time switch program.

| <i>Setting range</i> | <i>Unit</i> | <i>Factory setting</i> |
|----------------------|-------------|------------------------|
| 0...1                | Increment   | 1                      |

### Effect

Depending on the setting made, the circulating pump will be operated according to the following time switch program:

- 0 For the switching program of the circulating pump, the switching program of the controller internal heating circuit will be adopted.
- 1 Switching program according to the selected d.h.w. release (operating line 121).

## 4.37 Assignment of d.h.w. heating

### Benefits

- Assignment of d.h.w. heating to the respective consumers
- All relevant time switch programs are taken into consideration
- Controllers in holiday mode are taken into consideration

### Description

Determines the consumers for which d.h.w. will be heated and which time switch programs will be appropriately considered, also checking whether the relevant controllers are in holiday mode.

### Setting

1. Press the line selection buttons to select line 123.
2. Press the plus / minus buttons to select the required assignment.

123

| <u>Setting range</u> | <u>Unit</u> | <u>Factory setting</u> |
|----------------------|-------------|------------------------|
| 0...2                | Increment   | 2                      |

### Effect

Depending on the selection made, the d.h.w. will be heated for the following consumers:

- 0 For the local consumer only (RVA47.320)
- 1 for all consumers (controllers) in the same segment
- 2 For all consumers (controllers) in the LPB system

In the case of d.h.w. heating according to the heating circuit time switch program (line 121, setting 1), the time switch programs are used from the appropriate range for the release of d.h.w. heating at the nominal temperature setpoint, based on the consumers selected here.

With all settings (line 121, setting 0 - 2), it is checked whether the controllers of the selected range are in holiday mode. Controllers in holiday mode will **not** be considered for d.h.w. heating.

### → Important

If all controllers in the selected range are in holiday mode, d.h.w. heating will **not** be released. Only the frost protection function will remain active (function with no setting).

## 4.38 Number of d.h.w. charging cycles

### Benefits

- Choice of one or several d.h.w. charging cycles
- Forward shift of release matched to the number of d.h.w. charging cycles

### Description

With this setting, d.h.w. heating can be reduced to one charging cycle per day. The forward shift of d.h.w. heating against the range selected on operating line 123 will be appropriately adjusted.

### Note

This setting is effective only if on operating line 121 setting 1 (according to the heating circuit time switch program(s)) has been selected.

### Setting

1. Press the line selection buttons to select line 124.
2. Press the plus / minus buttons to select the type of d.h.w. heating.



| <i>Setting range</i> | <i>Unit</i> | <i>Factory setting</i> |
|----------------------|-------------|------------------------|
| 0...1                | Increment   | 1                      |

### Effect

According to the selection made, the controller releases d.h.w. heating either once or several times per day and adjusts the forward shift accordingly.

| <i>Setting</i> | <i>charging / day</i> | <i>Forward shift</i> |
|----------------|-----------------------|----------------------|
| 0              | one                   | 2.5 hours            |
| 1              | several               | 1 hour               |

### 4.38.1 Once per day with a forward shift of 2.5 hours

#### **Setting 0**

The number of daily releases for d.h.w. heating at the nominal temperature setpoint is limited to one. Also with this setting, the switch-on point is shifted forward by 2.5 hours against the range selected on line 123.

On days, on which space heating at the nominal room temperature setpoint is provided for 24 hours, d.h.w. heating is released at midnight for 2.5 hours.

### 4.38.2 Several times per day with a forward shift of 1 hour

#### **Setting 1**

The number of d.h.w. charging cycles will not be limited. Also with this setting, the switch-on point is shifted forward by one hour against the range selected on line 123.

## 4.39 Type of d.h.w. demand

### Benefit

- Possibility of using d.h.w. storage tanks equipped with a control thermostat

### Description

Defines the type of d.h.w. control (via d.h.w. sensor or control thermostat).

### → Note

Setting of this function has an impact on the automatic generation of the type of plant. Operating line 53.

### Setting

1. Press the line selection buttons to select line 125.
2. Press the plus / minus buttons to select the type of d.h.w. demand.

| <u>Setting range</u> | <u>Unit</u> | <u>Factory setting</u> |
|----------------------|-------------|------------------------|
| 0 / 1                | Increment   | 0                      |

### Effect

By making this setting, the controller takes into account the signal fed to it by the d.h.w. sensor connected to terminal B3.

Entry:

- 0: Temperature sensor: The temperature measured with the sensor connected to terminal B3 is used for the control of the d.h.w. temperature.
- 1: Control thermostat: The switching status of the control thermostat connected to terminal B3 is used for the control of the d.h.w. temperature.

### → Important

The contacts of the control thermostat must be suited for extra low voltage (gold-plated)!

### Difference

#### When using a d.h.w. temperature sensor:

The controller calculates the switching points with the respective switching differential in function of the d.h.w. temperature setpoint entered.

|                                    |   |                                      |
|------------------------------------|---|--------------------------------------|
| Sensor / line with a short-circuit | = | fault status signal                  |
| Measuring signal present           | = | d.h.w. according to current setpoint |
| Sensor / line with a short-circuit | = | no d.h.w.                            |

#### When using a d.h.w. control thermostat:

The controller takes into consideration the switching statuses of the control thermostat.

|                             |   |                                     |
|-----------------------------|---|-------------------------------------|
| Contact closed              | = | D.h.w. charging ON                  |
| Contact open                | = | D.h.w. charging OFF                 |
| Contact resistance too high | = | fault status signal from thermostat |

→ Note

When using a d.h.w. control thermostat, reduced operation is not possible.

Important when using a d.h.w. control thermostat

- The nominal d.h.w. temperature setpoint (line 13) must be equal to or higher than the setpoint adjusted on the control thermostat (thermostat is calibrated at switch-off point).
- Boost of the flow temperature setpoint (setting on line 126) must be minimum of 10 °C (has an impact on the charging time).
- In that case, frost protection for d.h.w. is not ensured

**D.h.w. control thermostat (example)**

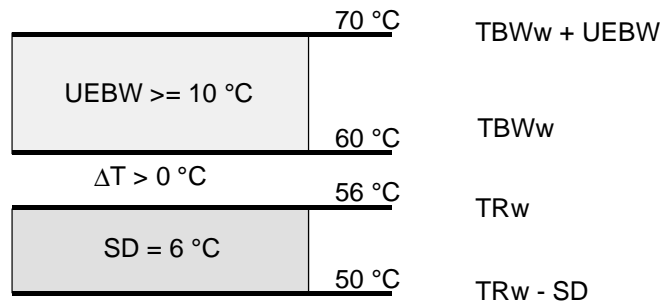

2371Z36

- UEBW = Boost of temperature setpoint (setting 126)
- TBW<sub>w</sub> = Nominal setpoint of d.h.w. temperature (setting on line 13)
- TR<sub>w</sub> - SD = Setpoint of control thermostat minus switching differential
- TR<sub>w</sub> = Setpoint of control thermostat (point of calibration)

## 4.40 Boost of flow temperature setpoint for d.h.w.

### Benefit

- Efficient d.h.w. heating

### Description

To allow the d.h.w. to be heated up, the boiler temperature must be higher than the d.h.w. setpoint.

### Setting

1. Press the line selection buttons to select line 126.
2. Press the plus / minus buttons to adjust the setpoint boost.

126

| <u>Setting range</u> | <u>Unit</u> | <u>Factory setting</u> |
|----------------------|-------------|------------------------|
| 0...30               | °C (K)      | 16                     |

### Effect

The setting will raise the boiler temperature setpoint when there is demand for d.h.w.

Increase: Heating up time will become shorter  
More overshoot

Decrease: Heating up time will become longer  
Less overshoot

### Boiler boost

Using the two settings, the controller generates the boiler temperature setpoint for d.h.w. heating.

|                     |                                        |
|---------------------|----------------------------------------|
| Setting on line 13  | Nominal setpoint of d.h.w. temperature |
| Setting on line 126 | <u>Boost</u>                           |
| Total               | Boiler temperature setpoint            |

### → Note

For d.h.w. control, refer to section "Switching differential of d.h.w. temperature" (line 41 OEM).

## 4.41 D.h.w. priority

### Benefit

- Optimum allocation of boilers' heat output

### Description

Defines the priority of d.h.w. heating over space heating.

### Setting



1. Press the line selection buttons to select line 127.
2. Press the plus / minus buttons to select the type of d.h.w. priority.

| <i>Setting range</i> | <i>Unit</i> | <i>Factory setting</i> |
|----------------------|-------------|------------------------|
| 0...3                | Increment   | 1                      |

### Effect

During d.h.w. heating, space heating will be restricted, depending on the setting made.

Entry:

#### **0 Absolute priority**

The controller-internal heating circuit and the heating circuits of other controllers connected to the LPB will be locked until the d.h.w. is heated up. The primary pump remains in operation.

- 1 Shifting priority** If the capacity of the heat generating equipment is no longer sufficient, the amount of heat supplied to the heating circuits will be restricted until d.h.w. heating is terminated.

#### **2 No priority**

D.h.w. heating and space heating at the same time.

In the case of tightly sized boilers and mixing heating circuits, the setpoint may not be reached if the heating load is great, since too much heat is required for space heating.

#### **3 Shifting / absolute priority**

If the capacity of the heat generating equipment is no longer sufficient, the pump heating circuits will be switched off and the amount of heat supplied to the mixing heating circuits restricted until d.h.w. heating is terminated.

### Frost protection for the plant

Frost protection for the plant is fully active only in the case of setting 2. With setting 0 or 1, it will be partly or fully restricted. If the boiler is correctly sized, frost protection for the plant is also ensured when using setting 1. In the case of plants where there is a considerable risk of frost (e.g. plants with outdoor heating), setting 0 should not be used.

## 4.41.1 Shifting priority

The purpose of the function "Shifting priority" is to achieve optimum d.h.w. heating. This means that during d.h.w. heating, the actual boiler temperature should be as close as possible to the boiler temperature setpoint without shutting down the burner. To achieve this, it may be necessary to restrict the heating circuits by means of a locking signal. Dies wird durch ein Temperatur-Zeit-Integral gebildet.

Depending on the consumer, the locking signal will lead to switching on / off or a setpoint reduction.

### Effect on two-position loads

Cycling or deactivation of the pumps will reduce the amount of heat drawn from the heat source. This will considerably shorten the time required for heating up the d.h.w.

- Heating circuit pump:

| <i>Status</i>         | <i>Effect</i>               |
|-----------------------|-----------------------------|
| Locking signal < 20 % | Normal pump operation       |
| Locking signal > 20 % | Heating circuit pump cycles |
| Locking signal > 93 % | Heating circuit pump OFF    |

- D.h.w. pump or boiler pump:  
No effect

### Switching point

Through the generation of the temperature-time integral it is not only the period of time that is considered, but also the extent of the undershoot. This means that when the crossing is significant, the pumps will be deactivated earlier.

### Effect on modulating loads

The consumption of heat is considerably reduced through the reduction of the flow temperature setpoints. This reduces considerably the heating up time for d.h.w., with a minimum impact on the heating circuits.

- Mixing valve:

| <i>Status</i>                 | <i>Effect</i>                                                                                                                                 |
|-------------------------------|-----------------------------------------------------------------------------------------------------------------------------------------------|
| Locking signal > 0 %          | Flow temperature setpoints will be lowered.<br>The extent of lowering is dependent on the magnitude and the period of time of the undershoot. |
| Locking signal reduced to 0 % | Setpoints according to the normal control condition                                                                                           |

### Setpoint reduction

Through the generation of the temperature-time integral it is not only the period of time that is considered, but also the extent of the undershoot. This means that when the undershoot is significant, the setpoint reduction will be greater.

## Temperature-time integral

This temperature-time integral generates the locking signal for restricting the heating circuits.

When generating the locking signal, one of four different procedures is used:

| Diagram           | Procedure                                                                                                                                                                                                                         |
|-------------------|-----------------------------------------------------------------------------------------------------------------------------------------------------------------------------------------------------------------------------------|
| a to b            | Within a foreseeable period of time, the actual value of the boiler temperature (TKx) will <b>no</b> longer be within the switching differential of the boiler temperature setpoint.<br><b>→ Locking signal will be increased</b> |
| b to c and d to e | Within a foreseeable period of time, the actual boiler temperature (TKx) will lie within the switching differential of the boiler temperature setpoint.<br><b>→ Locking signal will remain at a constant level</b>                |
| c to d and e to f | Within a foreseeable period of time, the actual boiler temperature (TKx) will lie <b>above</b> TKw.<br><b>→ Locking signal will be decreased</b>                                                                                  |
| f                 | The actual boiler temperature (TKx) <b>exceeds</b> the boiler temperature setpoint.<br><b>→ Locking signal will be set to 0 %.</b>                                                                                                |

Example:

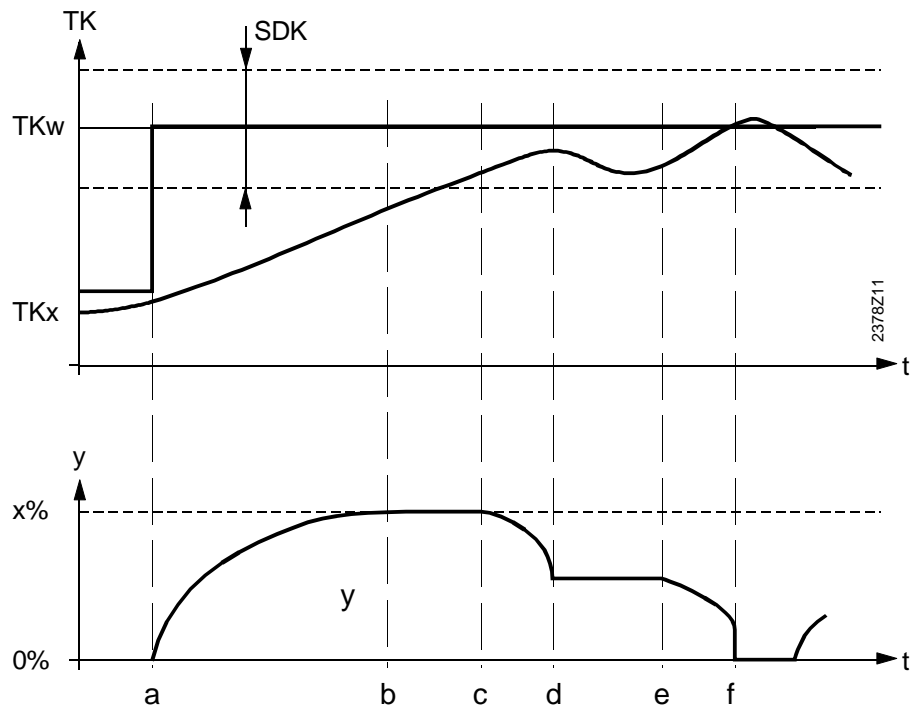

- a Start of d.h.w. heating
- TK Boiler temperature
- TKw Boiler temperature setpoint
- TKx Actual value of boiler temperature
- SDK Boiler's switching differential (factory setting 8K)
- t Time
- Y Locking signal

## 4.42 Demand for heat with reduced d.h.w. setpoint

### Benefit

- Selectable type of heat demand with reduced d.h.w. setpoint

### Description

In connection with alternative sources of energy, an early release of heat generation (BMUs) for d.h.w. heating outside the main occupancy times is often undesirable. A choice of two different procedures is available releasing the cascade earlier or later.

### Setting

1. Press the line selection buttons to select line 129.
2. Press the plus / minus buttons to select the required assignment.



| <u>Setting range</u> | <u>Unit</u> | <u>Factory setting</u> |
|----------------------|-------------|------------------------|
| 0 / 1                | -           | 1                      |

### Effect

The setting determines whether or not heat generation will be released for maintaining the reduced d.h.w. setpoint:

- 0      **No** (use with buffer storage tank and alternative heat source).  
Outside the main occupancy hours, the attempt is made to bring the d.h.w. temperature to the reduced setpoint level using energy from the buffer storage tank. This means that the d.h.w. charging pump runs but the demand for heat will be suppressed. Heat generation for d.h.w. charging will be released only (d.h.w. push) when the d.h.w. temperature has dropped below the reduced setpoint by twice the d.h.w. switching differential ( $41_{\text{OEM}}$ ).
- 1      **Yes** (standard procedure).  
Outside the main occupancy hours, the d.h.w. temperature is raised to the level of the reduced setpoint. This is accomplished by sensing a heat demand signal to the heat source (individual boiler or cascade).

## Cascade settings

### 4.43 Changeover of boiler sequence in cascades

#### Benefits

- Even wear and tear of the boilers in a cascade, or
- Selectable fixed switching on / off sequence
- Different time intervals for changeover of boiler sequence can be set

#### Description

The parameter determines whether or not the switching on / off sequence of the boilers shall be changed according to an adjustable period of time.

#### Setting



1. Press the line selection buttons to select line 130.
2. Press the plus / minus buttons to enter the number of operating hours after which the changeover of boiler sequence shall take place.

| Setting range  | Unit      | Factory setting |
|----------------|-----------|-----------------|
| --- / 10...990 | - / hours | 500             |

#### Effect

--- Fixed switching on / off sequence of the boilers in the cascade. The lead boiler can be freely selected (refer to operating line 132); the other boilers are switched on and off in the order of the device addresses / subaddresses.

10...990 On completion of the number of operating hours set here, the switching on / off sequence of the boilers in the cascade will change. This means that the boiler with the next higher device address will become the lead boiler.

#### Example:

Example of four boilers with a set differential of 100 operating hours.

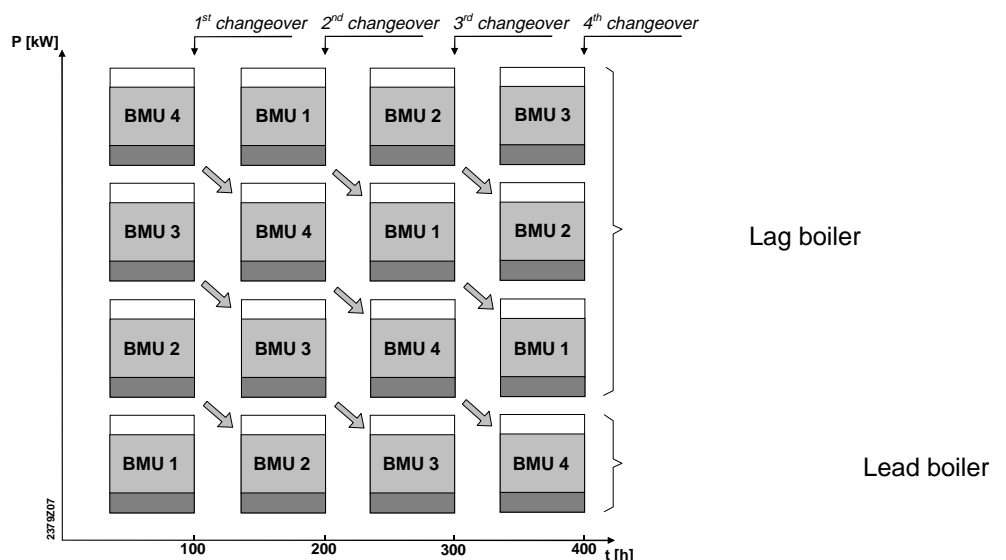

t = Total number of operating hours of all lead boilers [h]  
P = Total output of cascade [kW]

## 4.44 Exemption from automatic changeover of the boiler sequence

### Benefit

- Individual boilers can be exempted from automatic changeover

### Description

Use this function if you want to operate a certain boiler as the first and / or last boiler of the switching on sequence.

### Setting

131

1. Press the line selection buttons to select line 131.
2. Press the plus / minus button to enter the boiler(s) to be exempted from automatic changeover.

| <i>Setting range</i> | <i>Unit</i> | <i>Factory setting</i> |
|----------------------|-------------|------------------------|
| 0...3                | -           | 0                      |

### → Important

The setting of this parameter has an effect only if on operating line “Changeover of boiler sequence in a cascade” (line 130) the setting “Automatic changeover according to the number of operating hours” (10...990 h) has been selected.

### Effect

Depending on the selected setting, the respective boiler will be exempted from automatic changeover of the boiler sequence.

Entry:

#### **0 No exemption.**

The switching on sequence of the boilers will change on completion of the number of operating hours set (line 130).

#### **1 The first boiler is exempted.**

The first boiler in the addressing scheme always remains the lead boiler. With the other boilers, the switching on sequence changes when the set number of operating hours have elapsed (line 130).

#### **2 The last boiler is exempted.**

The last boiler in the addressing scheme always remains the last boiler. The other boilers will be switched over on completion of the number of operating hours set (line 130).

#### **3 The first and the last boiler are exempted.**

The first boiler in the addressing scheme always remains the lead boiler. the last boiler in the addressing scheme always remains the last boiler. The boilers in between will be switched over on completion of the number of operating hours set (line 130).

### → Note

The boiler sequence is to be determined on operating lines “Device address” (line 140) and “Segment address” (line 141).

## 4.45 Lead boiler with a fixed changeover of the boiler sequence

### Benefits

- Lead boiler of the cascade with a fixed changeover of the boiler sequence can be freely selected
- Better adjustment to the plant's demand profile by selecting a suitable type of boiler as the lead boiler

### Description

With a fixed changeover of the boiler sequence (refer to operating line 130), the lead boiler can be freely selected.

### Setting

1. Press the line selection buttons to select line 132.
2. Press the plus / minus buttons to select the required lead boiler.



| <i>Setting range</i> | <i>Unit</i> | <i>Factory setting</i> |
|----------------------|-------------|------------------------|
| 00.1...16.3          | -           | -                      |

### Effect

The boiler defined as the lead boiler is always the first boiler to be switched on and the last to be switched off. The other boilers are switched on and off in accordance with the order of the device addresses / device subaddresses.

For example, display 1.1 means that device 1 (in segment 0), device subaddress 1 (BMU 1), is the selected lead boiler.

### → Note

All cascade boilers must be in segment 0 so that the heat demand signals from all segments can be acquired. For more detailed information about the device address / device subaddress, refer to "Local Process Bus (LPB), Basic Documentation, System Engineering" (document no. CE1P2370E).

### → Important

This setting has an effect only if function "Changeover of boiler sequence in cascades" (operating line 130) is set to "---" = fixed switching on / off sequence.

## 4.46 Switch-on delay lag boilers

### Benefits

- Smooth operation due to stable operating conditions
- Adjustable rate of release of total capacity

### Description

After a BMU has switched on, an adjustable period of time must elapse until another BMU can be switched on.

### Setting

133

1. Press the line selection buttons to select line 133.
2. Press the plus / minus buttons to enter the number of minutes on completion of which another BMU can be switched on.

| <u>Setting range</u> | <u>Unit</u> | <u>Factory setting</u> |
|----------------------|-------------|------------------------|
| 1...120              | Minutes     | 5                      |

### Effect

For stability reasons, each BMU added to the cascade will first run in its basic stage for about one minute. This minute is already contained in the adjusted switch-on delay. Correct adjustment of the switch-on delay ensures that plant operating conditions will be stable. This prevents frequent cycling of the BMUs.

## 4.47 Restart lock of BMUs

### Benefit

- Too frequent switching on / off cycles of the BMUs will be avoided

### Description

A BMU that has just been switched off can be switched on again only after an adjustable period of time has elapsed.

### Setting

134

1. Press the line selection buttons to select line 134.
2. Press the plus / minus buttons to enter the number of minutes on completion of which a switched off BMU can be switched on again.

| <u>Setting range</u> | <u>Unit</u> | <u>Factory setting</u> |
|----------------------|-------------|------------------------|
| 0...1800             | Seconds     | 300                    |

### Effect

The restart lock ensures that a BMU that has just been switched off will not be switched on again a short time later. The BMU will be released again only after the adjusted period of time has elapsed. This prevents frequent cycling of the BMUs and ensures that plant conditions will be more stable.

## LPB / system

### Benefits

- Creation of systems
- Wide field of use with a smaller number of unit versions
- Plants can be extended in a straightforward manner

### Description

The LPB is used as a communication basis for generating a system with additional ALBATROS™ controllers or controllers of other manufacture.

## 4.48 LPB device address

### Description

The device address and the segment address are used as destinations in the bus system (similar to a postal address). To ensure communication, each device must be correctly addressed.

### Setting



1. Press the line selection buttons to select line 140.
2. Press the plus / minus buttons to enter the device number.

| <i>Setting range</i> | <i>Unit</i> | <i>Factory setting</i> |
|----------------------|-------------|------------------------|
| 0...16               | Increment   | 1                      |

### Effect

Entry of the device address is especially important when using combinations of units, or in a system. The addresses classify the controllers within a segment.

Entry:

| <i>Address</i> | <i>Effect</i> | <i>Example</i>                                                                                                                                                                                        |
|----------------|---------------|-------------------------------------------------------------------------------------------------------------------------------------------------------------------------------------------------------|
| 0              | Standalone    | Single controllers                                                                                                                                                                                    |
| 1              | Master (LPB)  | <ul style="list-style-type: none"> <li>– Controllers with master function</li> <li>– Cascade master</li> <li>– Heat generation master</li> <li>– Consumer master in the respective segment</li> </ul> |
| 2...16         | Master (LPB)  | <ul style="list-style-type: none"> <li>– Controllers with slave function</li> <li>– Other heat generation controller</li> <li>– Heating circuit controller</li> <li>– D.h.w. controller</li> </ul>    |

### Device address

The device addresses should be assigned in consecutive order in accordance with the controllers connected. It is not permitted to assign an address several times within a bus segment, since this would lead to communication errors. Each segment must have a device as a master (address 1).

### → Note

For more detailed information about the addressing of devices in a system, refer to "Local Process Bus (LPB), Basic Documentation, System Engineering" (document no. CE1P2370E).

## 4.49 LPB segment address

### Description

The segment address and the device address are used as destinations in the bus system (similar to a postal address). To ensure communication, each device must be correctly addressed.

### Setting



1. Press the line selection buttons to select line 141.
2. Press the plus / minus buttons to enter the segment address.

| <i>Setting range</i> | <i>Unit</i> | <i>Factory setting</i> |
|----------------------|-------------|------------------------|
| 0...14               | Increment   | 0                      |

### Effect

Entry of the segment address is especially important when used in a system. With this setting, the system can be subdivided into a number of segments.

Entry:

|        |                         |
|--------|-------------------------|
| 0      | Heat generation segment |
| 1...14 | Heat consumer segment   |

### Segment number

A bus segment is comprised of a number of devices that are used in the same place of application. All devices in a segment must carry the same segment address.

### → Note

For more detailed information about the addressing of devices in a system, refer to "Local Process Bus (LPB), Basic Documentation, System Engineering" (document no. CE1P2370E).

## 4.50 Bus power supply

### Benefits

- A central bus power supply is not required in systems with up to 16 devices
- Straightforward extension of systems

### Description

The bus power supply via the controllers enables the bus system to be powered directly by the individual controllers (no central bus power supply).

### Setting



1. Press the line selection buttons to select line 142.
2. Press the plus / minus buttons to select the type of bus power supply.

| <u>Setting range</u> | <u>Unit</u> | <u>Factory setting</u> |
|----------------------|-------------|------------------------|
| 0 / 1                | Increment   | 1                      |

### Effect

Entry:

- 0 Off  
No bus power supply via the controller.
- 1 Automatically  
The bus power supply (LPB) via the controller is automatically switched on and off depending on the requirements of the LPB.

### → Note

The actual status of the power supply is shown on line 143.

### Bus power supply

The bus system (LPB) can be powered either via the individual controller bus power supplies or via a central bus power supply.

### → Note

For more detailed information about the bus power supply and its engineering, refer to "Local Process Bus (LPB), Basic Documentation, System Engineering" (document no. CE1P2370E).

## 4.51 Display of LPB power supply

### Benefit

- Overview of operational status of the bus power supply via controllers

### Description

The display shows whether the controller currently powers the bus (LPB).

### Setting



1. Press the line selection buttons to select line 143.
2. No setting can be made with the plus / minus buttons.

| <i>Display</i> | <i>Unit</i> |
|----------------|-------------|
| ON / OFF       | -           |

### Effect

The status of the bus power supply via controllers will automatically be displayed on this operating line.

Display:

- ON The bus power supply via controllers is currently active.  
At the moment, the controller supplies some of the power required by the bus.
- OFF The bus power supply via controllers is currently inactive.

### Bus power supply

Power supply to the bus can be accomplished in different ways. The respective setting is made on line 142.

## 4.52 Display of LPB communication

### Benefit

- Overview of communication status of bus (LPB)

### Description

Indicates whether communication on the LPB is currently active.

### Setting



1. Press the line selection buttons to select line 144.
2. No setting can be made with the plus / minus buttons.

| <i>Display</i> | <i>Unit</i> |
|----------------|-------------|
| ON / OFF       | -           |

### Effect

The status of the BUS communication will automatically be displayed on this line.

### Display

- ON Communication active  
The controller communicates with another controller via the LPB.
- OFF Communication inactive

## 4.53 Range of action of central changeover

### Benefit

- The range of action of the central changeover actions can be defined

### Description

Function for defining the range of action of the central changeover actions.

### Setting

145

1. Press the line selection buttons to select line 145.
2. Press the plus / minus buttons to select the required range of action of changeover.

| <i>Setting range</i> | <i>Unit</i> | <i>Factory setting</i> |
|----------------------|-------------|------------------------|
| 0 / 1                | Increment   | 1                      |

### Effect

The range of action can be defined for the central changeover actions "Changeover of operating mode", "Summer / winter changeover" and "Standby". The range of action can be defined by making the following settings:

- 0 Changeover takes place with all controllers in the same segment.
- 1 Changeover takes place with all controllers in the entire system (LPB).

### → Note

The setting is of importance only if the controller is defined as the master (address 0/1). With any other addressing, it has no effect.

## 4.54 Automatic summer / winter changeover

### Benefit

- Makes possible a uniform changeover of all heating circuits in the selected range of action

### Description

Summer / winter changeover of the selected range of action takes place when the changeover temperature set on operating line 16 is reached.

### Setting

146

1. Press the line selection buttons to select line 146.
2. Press the plus / minus buttons to select the effect of automatic summer / winter changeover.

| <u>Setting range</u> | <u>Unit</u> | <u>Factory setting</u> |
|----------------------|-------------|------------------------|
| 0 / 1                | Increment   | 0                      |

### Effect

The setting will change the effect of summer / winter changeover:

Entry:

- 0: Local effect  
Automatic summer / winter changeover switches the local heating circuit on and off.
- 1: Central effect  
Either the heating circuits of the segment or those of the entire system are switched on and off by automatic summer / winter changeover, depending on the setting made on operating line "Range of action of central changeover."

### → Important

Setting 1 (central effect) is active only if the controller has been defined as a master controller (setting on line 140 = 1).

## 4.55 Central standby switch

---

**Benefit**

- Central operation of the interconnected system

---

**Description**

From the master controller, the entire heating system can be switched to standby.

---

**Setting**

1. Press the line selection buttons to select line 147.
2. Press the plus / minus buttons to select central standby switching.

| <i>Setting range</i> | <i>Unit</i> | <i>Factory setting</i> |
|----------------------|-------------|------------------------|
| 0 / 1                | Increment   | 0                      |

---

**→ Important**

Setting 1 (central effect) is active only if the controller has been defined as a master controller (setting on line 140 = 1).

---

**Effect**

Entry:

0 = Central standby switching is deactivated

1 = Central standby switching is activated

---

**→ Important**

If central standby on the master controller is switched on, it can only be switched off again from the master controller!

---

**D.h.w.**

The central standby switch does not affect d.h.w. heating. This means that the d.h.w. is heated according to the settings made.

---

**Display**

If the function is activated from the master controller, the HC operating mode buttons  of all the relevant controllers in the segment or system will flash.

## 4.56 Clock mode

### Benefit

- Straightforward time synchronization of the controllers in the system

### Description

Clock operation is an important setting for time synchronization if several controllers are interconnected to form one system.

### Setting

1. Press the line selection buttons to select line 148.
2. Press the plus / minus buttons to select clock mode.



| <i>Setting range</i> | <i>Unit</i> | <i>Factory setting</i> |
|----------------------|-------------|------------------------|
| 0...3                | Increment   | 3                      |

### → Important

For time adjustment of the controllers connected to the system, **one** device per system must be set as a **system lock (setting 3)**.

### Effect

The setting will change the effect of the system time on the controller's time setting (settings on lines 1 to 2).

Entry:

#### 0: Autonomous clock

- The clock time on the unit can be adjusted
- The controller's clock time will **not** be matched to the system time

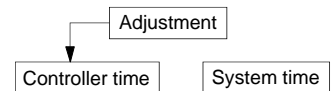

#### 1: System time

- The clock time on the unit cannot be adjusted
- The controller's clock time will automatically and continuously be matched to the system time

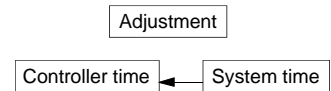

#### 2: System time with adjustment

- The clock time on the unit can be adjusted and, at the same time, adjusts the system time since the change will be adopted by the master
- The controller's clock time is still automatically and continuously matched to the system time

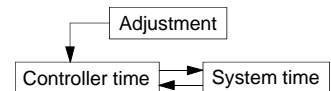

#### 3: System clock (master)

- The clock time on the unit can be adjusted and, at the same time, adjusts the system time
- The controller's time is used for the system

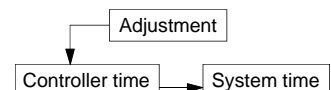

# Input H1

## 4.57 Input H1

### Benefits

- Changeover of operating mode via telephone (e.g. in a holiday house)
- Minimum demand for heat
- Heat generation lock
- demand for heat

### Description

Terminal H1 is an input that provides different functions, depending on the selected setting.

### Setting



1. Press the line selection buttons to select line 170.
2. Press the plus / minus buttons to select the required function.

| <u>Setting range</u> | <u>Unit</u> | <u>Factory setting</u> |
|----------------------|-------------|------------------------|
| 0...4                | Increment   | 0                      |

### Effect

With this setting, the function of terminal H1 can be changed. The selected function will be activated when the potential-free contact connected to terminal H1 closes or when an analog voltage signal of DC 0...10 V is transmitted.

Entry:

- 0 **Changeover of operating mode** (remote telephone switch) for heating circuit and d.h.w.: The operating mode is changed when the contact closes
- 1 **Changeover of operating mode** (remote telephone switch) for heating circuit only: The operating mode is changed when the contact closes
- 2 **Minimum setpoint of flow temperature, contact H1**  
The "Minimum setpoint of flow temperature contact H1" set on operating line 171 will be activated when the contact closes.
- 3 **Heat generation lock**  
The heat sources will be locked when the contact closes.
- 4 **Demand for heat**  
The demand for heat (between 0 and 130 °C) is delivered to the heat sources in the form of a voltage signal.

### → Note

When using terminal H1 as a contact (settings 0 -3), **several** switches can be connected in **parallel**. The function will be activated when one or several contacts close(s), depending on the selected setting.

When using terminal H1 as a voltage input (setting 4), it is **not** possible to connect several signals in parallel.

When two heat demand signals are received at the same time, one via contact H1 (settings 2 + 4) and another (LPB, d.h.w. or controller internally), the highest of them will be selected.

### → Important



The relay contacts must be suited for use with extra low voltage (gold-plated)

## 4.57.1 Changeover of operating mode (remote telephone switch)

### Setting 0 / 1

#### Description

A remote telephone switch is a potential-free relay contact, e.g. in the form of a modem, which can be switched by making a phone call plus dialing a code.

The operating mode is changed when the contact connected to terminal H1 (e.g. a remote telephone switch) closes. In that case, the LEDs in the operating mode buttons  and  will flash.

#### D.h.w.

Whether or not d.h.w. heating takes place when the remote telephone switch is activated depends on the setting made:

**Setting 0** D.h.w. heating is locked when changeover is activated.



**Setting 1** D.h.w. heating remains released when changeover is activated.



#### Effect

Activation of this function will produce different actions, depending on the function of the controller within the LPB system (also refer to "Local Process Bus (LPB), Basic Documentation, System Engineering, document no. CE1P2370E).

The effect depends on the setting made on operating line 145.

#### Changeover of system



|                                                          |                                                                                                                                                                                                                                                                                                                                                                                                                                                                               |
|----------------------------------------------------------|-------------------------------------------------------------------------------------------------------------------------------------------------------------------------------------------------------------------------------------------------------------------------------------------------------------------------------------------------------------------------------------------------------------------------------------------------------------------------------|
| <b>• Changeover of all controllers in the LPB system</b> |                                                                                                                                                                                                                                                                                                                                                                                                                                                                               |
| Prerequisite:                                            | <ul style="list-style-type: none"><li>– Operating line 145 must be set to 1 (range of action = entire system)</li><li>– The contact must be connected to the master controller in segment 0</li></ul> <p style="text-align: right;"><i>Possible address: Device address 1 (line 140)</i><br/><i>Segment address 0 (line 141)</i></p>                                                                                                                                          |
| Effect:                                                  | <ul style="list-style-type: none"><li>– All controllers in the system switch to operating mode</li><li>– With setting 0, d.h.w. heating is switched off in the entire system; with setting 1, it is released in the entire system</li><li>– With all controllers, operating mode changeover with the buttons is no longer possible</li><li>– When the contact of the remote telephone switch opens, all controllers will return to the operating mode selected last</li></ul> |
| Check                                                    | <ul style="list-style-type: none"><li>– Buttons  or  +  flash on all controllers in the system <sup>1)</sup></li></ul>                                                                                               |

<sup>1)</sup> With setting 0 as selected above (d.h.w. heating locked), the two buttons  and  will flash.

With setting 1 as selected above (d.h.w. heating remains released), only operating mode button  will flash.

Changeover of segment

| • <b>Changeover of all controllers in the same segment</b> |                                                                                                                                                                                                                                                                                                                                                                                                                                                                                                                |
|------------------------------------------------------------|----------------------------------------------------------------------------------------------------------------------------------------------------------------------------------------------------------------------------------------------------------------------------------------------------------------------------------------------------------------------------------------------------------------------------------------------------------------------------------------------------------------|
| Prerequisite:                                              | <ul style="list-style-type: none"> <li>- With segment 0, setting 0 must be made on operating line 145 (range of action of segment); with the other segments, the setting on operating line 145 has no impact.</li> <li>- The contact must be connected to the master controller in segments 1 to 14</li> </ul> <p style="text-align: right;"><i>Possible addresses: Device address 1 (line 140)</i><br/><i>Segment address 1...14 (line 141)</i></p>                                                           |
| Effect:                                                    | <ul style="list-style-type: none"> <li>- All controllers in the same segment switch to operating mode</li> <li>- With setting 0, d.h.w. heating is switched off in the entire segment; with setting 1, it is released in the entire segment</li> <li>- With all controllers in the same segment, operating mode changeover with the buttons is no longer possible</li> <li>- When the contact of the remote telephone switch opens, all controllers will return to the operating mode selected last</li> </ul> |
| Check                                                      | <ul style="list-style-type: none"> <li>- Buttons on all controllers in the same segment <sup>1)</sup></li> </ul>                                                                                                                                                                                                                                                                                                                                                                                               |

<sup>1)</sup> With setting 0 as selected above (d.h.w. heating locked), the two buttons  and  will flash.  
With setting 1 as selected above (d.h.w. heating remains released), only operating mode button  will flash.

#### 4.57.2 Minimum setpoint of flow temperature - contact H1

**see operating line 171**

##### **Setting 2**

#### 4.57.3 Heat generation lock

##### **Setting 3**

---

The heat sources will be locked when contact H1 closes (e.g. via ripple control).

All heat demand signals from the heating circuits connected to LPB and from the d.h.w. storage tank connected to the RVA47.320 will be ignored while frost protection for the boiler will remain ensured.

However, a local d.h.w. storage tank connected directly to the BMU can still trigger d.h.w. heating.

Chimney sweep function

---

The chimney sweep function can be activated directly on the BMU although the heat generation lock is switched on.

## 4.57.4 Demand for heat

### Setting 4

External consumers can transmit a demand for heat in the form of an analog voltage signal of DC 0...10 V. The RVA47.320 converts this voltage signal to a temperature setpoint of 0...130 °C and considers this value when generating the setpoint of the cascade.

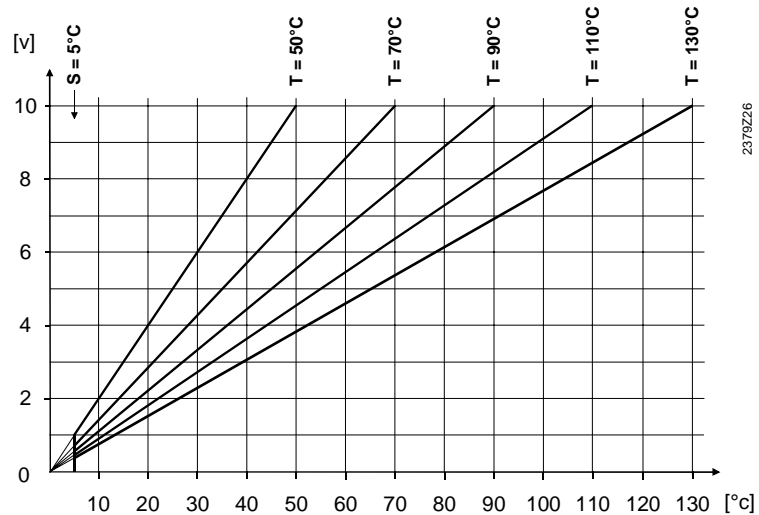

T = „Maximum value of heat demand“  
S = „Minimum limitation of heat demand“ = 5 °C

The setpoint for 10 V can be set with parameter “Maximum value of heat demand” (operating line 172, setting range 5...130 °C). The voltage corresponding to the displayed temperature can then be calculated as follows:

$$[V] = \frac{10 [V] * \text{"actual temperature" } [^{\circ}\text{C}]}{\text{"Maximum value of heat demand" } [^{\circ}\text{C}]}$$

## 4.58 Minimum setpoint of flow temperature - contact H1

### Benefits

- Handling of heat demand signals from units incompatible with LPB
- Temporary startup of boiler via switching contact

### Description

Function for setting the temperature at which the cascade or the boiler is maintained when contact H1 is closed.

### → Important

This setting is active only if on operating line 170 (input H1) the setting "Minimum setpoint of flow temperature contact H1" has been selected.

### Setting



1. Press the line selection buttons to select line 171.
2. Press the plus / minus buttons to set the required "Minimum setpoint of flow temperature contact H1".

| <i>Setting range</i>                                                                  | <i>Unit</i> | <i>Factory setting</i> |
|---------------------------------------------------------------------------------------|-------------|------------------------|
| 8...TKmax                                                                             | °C          | 70                     |
| ...TKmax    Maximum limitation of BMU setpoint, operating line 2 <small>OEM</small> . |             |                        |

### Effect

Function "Minimum setpoint of flow temperature contact H1" selected on line 170 will be activated when contact H1 closes. The heat source or the cascade will maintain the temperature level set here until either contact H1 reopens or more heat is demanded.

### → Notes

If several heat demand signals are received at the same time (LPB, contact H1, d.h.w., or from the controller itself), the highest of them will be selected.

If the demand for heat is so small that a single BMU running on its basic stage still produces too much heat, it will start cycling within the switching differential set on it. Otherwise, the required output will be provided through modulation of the burner.

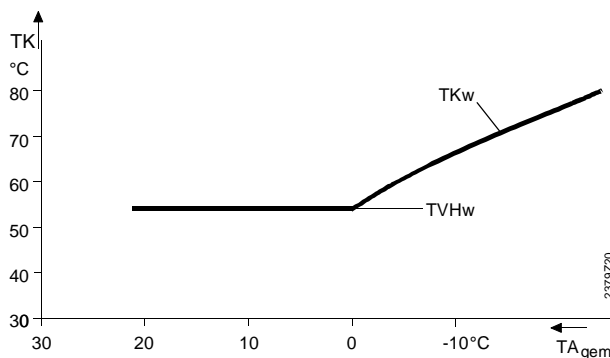

TVHw Setpoint of flow temperature - contact H

TKw Boiler temperature setpoint

## 4.59 Maximum value of heat demand signal DC 0...10 V (H1)

### Benefits

- Adjustable temperature range for heat demand signal via input H1
- Can be matched to the voltage outputs of devices of other manufacture

### Description

The parameter determines which temperature the maximum voltage of the setting "Heat demand via H1" (operating line 170, setting 4) corresponds to.

### → Important

This setting is active only if on operating line 170 (input H1) setting 4 "Heat demand DC 0...10 V" has been selected.

### Setting

172

1. Press the line selection buttons to select line 172.
2. Press the plus / minus buttons to set the required "Maximum value of the heat demand signal".

| <u>Setting range</u> | <u>Unit</u> | <u>Factory setting</u> |
|----------------------|-------------|------------------------|
| 5...130              | °C          | 100                    |

### Effect

This setting defines the temperature corresponding to 10 V of the setting "Heat demand via H1" (operating line 170, setting 4).

Based on this temperature, the controller converts the heat demand voltage signal to a temperature.

## 4.60 Operating action of contact connected to H1

### Benefits

- The operating action of the contact can be matched to the type of output signal delivered by a device of other manufacture
- More flexibility when selecting non-Landis & Staefa products (both operating actions can be considered)

### Description

This function enables the operating action of contact H1 to be matched to the operating action of a device of other manufacture.

### Setting

173

1. Press the line selection buttons to select line 173.
2. Press the plus / minus buttons to select the operating action of contact H1.

| <u>Setting range</u> | <u>Unit</u> | <u>Factory setting</u> |
|----------------------|-------------|------------------------|
| 0...1                | -           | 1                      |

### Entry:

- 0 The contact is a N.C. contact, which means that it is normally closed and opened only when the third party device delivers a signal.
- 1 The contact is a N.O. contact, which means that it is normally open and closed only when the third party device delivers a signal.

### → Note

If input H1 is used for a heat demand signal (line 170, setting 4), this setting will have no effect.

## 5 Description of OEM settings

→ For an overview of the settings and the setting procedure, refer to page 28.

### *Heat generation values OEM*

#### 5.1 Minimum limitation of boiler temperature setpoint (TKmin<sub>OEM</sub>)

##### Benefit

- Minimum limitation of the boiler temperature setpoint.

##### Description

This function provides minimum limitation of the boiler temperature setpoint.

##### Setting

1. Press the line selection buttons to select operating line 1<sub>OEM</sub>.
2. Press the plus / minus buttons to set the minimum limitation of the boiler temperature.



| <i>Setting range</i> | <i>Unit</i> | <i>Factory setting</i> |
|----------------------|-------------|------------------------|
| 8...95               | °C          | 8                      |

##### Effect

The setting ensures minimum limitation of the boiler temperature setpoint which can be adjusted on line 90 (TKmin).

## 5.2 Maximum limitation of boiler temperature setpoint

### Benefits

- Maximum limitation of the boiler temperature setpoint.
- Preset temperature for manual operation.

### Description

Maximum limitation of the boiler temperature setpoint and delivery of the flow temperature setpoint for the cascade in manual operation.

### Setting

1. Press the line selection buttons to select line 2<sub>OEM</sub>.
2. Press the plus / minus buttons to set the maximum limitation of the boiler temperature setpoint.



| <i>Setting range</i> | <i>Unit</i> | <i>Factory setting</i> |
|----------------------|-------------|------------------------|
| 8...120              | °C          | 80                     |

### Effect

This setting provides maximum limitation of the boiler and cascade flow temperature setpoint. The boilers controlled by the BMUs are operated at a temperature no higher than the adjusted temperature, even if the consumers call for more heat.

In **manual operation**, the value set is used directly as the flow temperature setpoint. The boilers controlled by the BMUs are operated at this temperature.

## 5.3 Pump overrun time

### Benefits

- Protects the boiler against overtemperatures
- Use of residual heat in the boiler.

### Description

Overrun of the primary, heating circuit and d.h.w. charging pump ensures that residual heat will be carried away from the pressureless header. This makes certain that the boiler pump controlled by the BMU will be able to draw the residual heat from the boiler, thus avoiding boiler overtemperatures and preventing the manual reset safety limit thermostat from cutting out.

### Setting

1. Press the line selection buttons to select line 8<sub>OEM</sub>.
2. Press the plus / minus buttons to set the pump overrun time.

8

| <i>Setting range</i> | <i>Unit</i> | <i>Factory setting</i> |
|----------------------|-------------|------------------------|
| 0...20               | min         | 5                      |

### Effect

All pumps that, at the time of burner shutdown of the last boiler, were operating, continue to run for the period of time set here. At the same time, the previous flow temperature setpoint remains valid, allowing the mixing valves of the controllers connected to LPB to stay open.

### Example

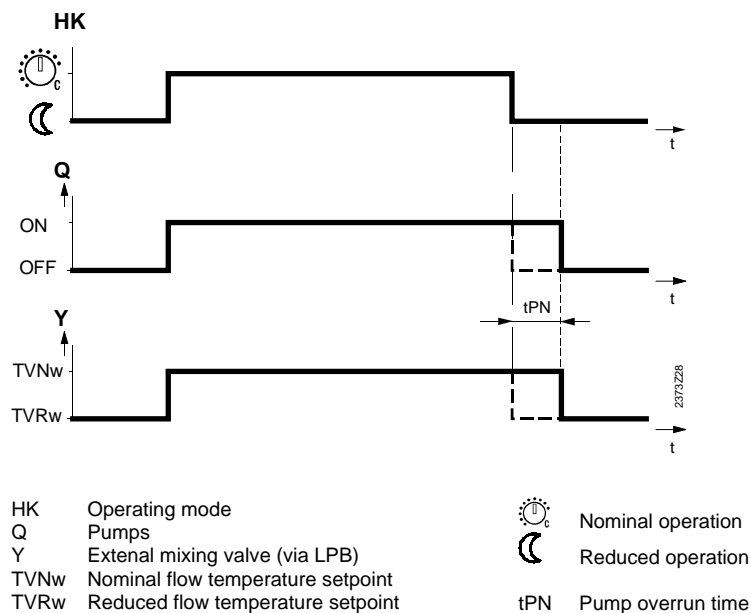

### → Note

With no burner shutdown, the general pump overrun time is one minute.

## 5.4 Minimum limitation of boiler return temperature

### Benefits

- The minimum boiler return temperature can be adjusted
- The effect on the consumers can be adjusted

### Description

The setting defines the permitted minimum boiler return temperature.

### Setting

1. Press the line selection buttons to select line 22<sub>OEM</sub>.
2. Press the plus / minus buttons to set the required minimum limitation of the boiler return temperature.

22

| <i>Setting range</i> | <i>Unit</i> | <i>Factory setting</i> |
|----------------------|-------------|------------------------|
| 8...95               | °C          | 8                      |

### Effect

If the boiler return temperature drops below the minimum limit set here, the consumers' heat consumption will be restricted.

## 5.5 Calibration of actual output of BMU 1 - 4

### Benefits

- More accurate control through optimized signal transmission.
- Calibration of the output signals delivered by the BMUs to match the actual values.

### Description

The output signals delivered by the BMUs can be calibrated to match the actual load. This enhances the control performance.

### Setting

25  
26  
27  
28

1. Press the line selection buttons to select line 25<sub>OEM</sub> - 28<sub>OEM</sub>.
2. Press the plus / minus buttons to adjust the calibration factors.

| Setting range | Unit | Factory setting |
|---------------|------|-----------------|
| -100...100    | -    | 0               |

In that case:

- Operating line 25 = BMU 1
- Operating line 26 = BMU 2
- Operating line 27 = BMU 3
- Operating line 28 = BMU 4

### Effect

The output signal delivered by the respective BMU is corrected by the adjusted factor and then used for controller-internal calculations.

In principle, operation without the adjusted calibration factor is possible, but to achieve the greatest possible accuracy the adjustment should be made.

### Calculation

Calculation of the calibration factor for the respective BMU is made based on the following formula:

$$K_{\%} = \frac{P_{\%GS} - \frac{P_{GS}}{P_N} \cdot 100}{1 - \frac{P_{\%GS}}{100}}$$

Legend

|                  |                                    |     |
|------------------|------------------------------------|-----|
| K <sub>%</sub>   | Calibration factor                 | [%] |
| P <sub>%GS</sub> | Output provided on the basic stage | [%] |
| P <sub>GS</sub>  | Output on the basic stage          | [W] |
| P <sub>N</sub>   | Nominal output                     | [W] |

### → Note

The value of P<sub>%GS</sub> is obtained by making a readout with the ACS69 service tool. It is displayed on the "Heat source status" page under the name of "Actual output value BMU X". The values of P<sub>GS</sub> and P<sub>N</sub> are given on the type field of the BMUs.

## Space heating OEM

### 5.6 Gain factor for room temperature influence (KORR)

#### Benefit

- The influence of room temperature deviations on the controlled system can be adjusted

#### Note

Defines the influence of room temperature setpoint deviations on the controlled system. The room temperature influence can be activated and deactivated (setting on line 101).

#### Setting

1. Press the line selection buttons to select operating line 30<sub>OEM</sub>.
2. Press the plus / minus buttons to set the gain factor.

30

| <u>Setting range</u> | <u>Unit</u> | <u>Factory setting</u> |
|----------------------|-------------|------------------------|
| 0...20               | -           | 4                      |

#### Effect

Changing this setting has the following impact:

Entry:

Increase: Authority of room temperature influence will increase

Decrease: Authority of room temperature influence will decrease

#### Correction

The value of setting 30<sub>OEM</sub> is divided by 2 and multiplied by the differential (room temperature setpoint – actual room temperature).

The result is then added to the room temperature setpoint.

$$TR_{wk} = TR_w + \frac{30_{OEM}}{2} (TR_w - TR_x)$$

TR<sub>w</sub> Room temperature setpoint

TR<sub>x</sub> Actual value of room temperature

TR<sub>wk</sub> Corrected room temperature setpoint

#### → Note

The gain factor for room temperature influence is only active when a room unit is connected.

## 5.7 Constant for quick setback (KON)

### Benefit

- Making use of the building's thermal storage capacity

### Description

Quick setback is dependent on whether or not a room temperature sensor is used. A differentiation is made between quick setback with and without room temperature sensor.

### → Important

This setting is active only if **no** room temperature sensor is used.

### Setting

1. Press the line selection buttons to select line 31<sub>OEM</sub>.
2. Press the plus / minus buttons to set the constant.

**31**

| <i>Setting range</i> | <i>Unit</i> | <i>Factory setting</i> |
|----------------------|-------------|------------------------|
| 0...20               | -           | 2                      |

### Effect

The duration of quick setback will be changed.

Entry:

Increase: Setback time will become longer  
For well insulated buildings that cool down slowly

Decrease: Setback time will become shorter  
For poorly insulated buildings that cool down rather quickly

### quick setback: no room temperature detector

Quick setback is started as soon as a change to a lower room temperature setpoint takes place (e.g. switching times in automatic mode).

The heating circuit pump will be deactivated until the quick setback time has elapsed, which is generated from setting 23<sub>OEM</sub>, the composite outside temperature and the room temperature setpoint change.

The quick setback time is limited to a maximum of 15 hours.

### Example

The example applies to a setpoint step change of 4 °C (e.g. TRw from 20 to 16 °C):

| TA <sub>gem</sub> | Setting 31 <sub>OEM</sub> |     |    |           |         |         |
|-------------------|---------------------------|-----|----|-----------|---------|---------|
|                   | 0                         | 4   | 8  | 12        | 15      | 20      |
| - 20              | 0                         | 0   | 0  | 0         | 0       | 0       |
| - 10              | 0                         | 0.5 | 1  | 1.5       | 2       | 2.5     |
| 0                 | 0                         | 3   | 6  | 9         | 11      | 15      |
| +10               | 0                         | 5   | 11 | 15 (16.5) | 15 (21) | 15 (27) |
| Values in hours   |                           |     |    |           |         |         |

### → Note

If a room temperature sensor is connected, the quick setback time will not be generated from this setting. For details, refer to section "Quick setback with room temperature sensor" (Chapter 6, "Function with no settings").

## 5.8 Boost of room temperature setpoint

### Benefit

- Reduction of the room's heating up time

### → Note

Boosts the room temperature setpoint temporarily, aimed at achieving shorter heating up times for the room. This setting is active only if a room temperature sensor is used.

### Setting

1. Press the line selection buttons to select line 32<sub>OEM</sub>.
2. Press the plus / minus buttons to adjust the room temperature setpoint boost.

**32**

| Setting range | Unit   | Factory setting |
|---------------|--------|-----------------|
| 0...20        | °C (K) | 5               |

### Effect

The duration of boost heating will be changed.

Entry:

Increase: More setpoint boost  
Heating up time will become shorter

Decrease: Less setpoint boost  
Heating up time will become longer

### boost heating

Boost heating is started as soon as switching to a higher room temperature setpoint occurs (e.g. switching times in automatic mode).

The room temperature setpoint will be raised by the setting made on line until the room is heated up ( $TR_w - \frac{1}{4} \text{ °C}$ ).

The boost produces an increase in the flow temperature setpoint.

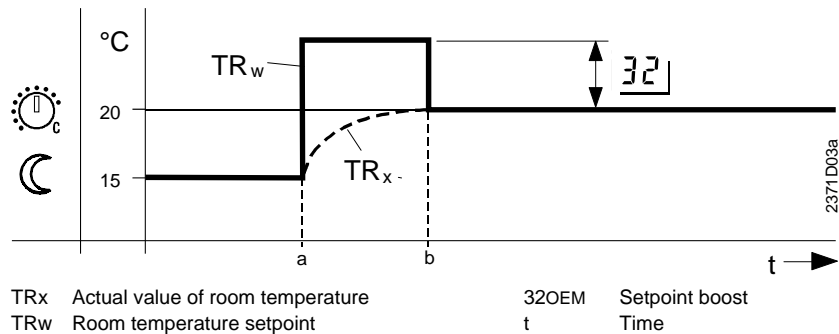

## 5.9 Frost protection for the plant

**Benefit** • Protects the plant against freezing

**Description** When this function is activated and there is a risk of frost, the heating will automatically switch on, thus preventing the heating plant from freezing.

→ Important This function is ensured only if the plant works properly and is fully operational!

**Setting**

1. Press the line selection buttons to select line 33<sub>OEM</sub>.
2. Press the plus / minus buttons to activate or deactivate the frost protection for the plant.

**33**

| Setting range | Unit | Factory setting |
|---------------|------|-----------------|
| 0 / 1         | -    | 1               |

**Effect** The plant will be protected by activating the pumps.

Entry:

- 0 Frost protection for the plant **OFF**  
Function deactivated
- 1 Frost protection for the plant **ON**  
Function activated

**Anlagefrostschutz** The heating circuit pump will be switched on in function of the actual **outside temperature**, even if there is no demand for heat.

| Outside temperature | Pump                                  | Diagram |
|---------------------|---------------------------------------|---------|
| ... -4°C            | Continuously ON                       | ON      |
| -5...-1.5 °C        | ON for 10 minutes at 6-hour intervals | takt    |
| 1.5 °C...           | Continuously OFF                      | OFF     |

**Exception** Between -4...-5°C, different statuses can occur. In this temperature range, it is decisive which situation prevailed:

- If the temperature was previously higher (in the range of "takt"), the pump is switched on / off also in the range -4 to -5 °C and is continuously activated only when the outside temperature is lower
- If the temperature was previously lower (in the range of "ON"), the pump is continuously activated also in the range up to -4 °C and is switched on / off when the outside temperature is higher

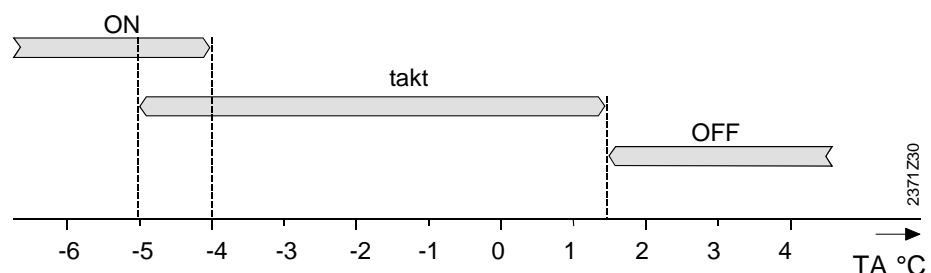

## 5.10 Overtemperature protection

### Benefits

- Prevents overtemperatures in pump heating circuits
- Enhances the control performance of a pump heating circuit

### Description

The flow temperature can be higher than that called for by the pump heating circuit (e.g. in the case of a higher setpoint demand by another consumer). The controller offsets the surplus energy by letting the pump cycle, thus preventing the pump heating circuit from overheating.

### Setting

34

1. Press the line selection buttons to select operating line 34<sub>OEM</sub>.
2. Press the plus / minus buttons to activate or deactivate the overtemperature protection.

| <u>Setting range</u> | <u>Unit</u> | <u>Factory setting</u> |
|----------------------|-------------|------------------------|
| 0 / 1                | -           | 1                      |

### Effect

The pump of the pump heating circuit will cycle in a way that the effect of too high flow temperatures will be offset.

- 0      Overtemperature protection deactivated  
1      Overtemperature protection activated

The cycling period is fixed at 10 min. This period of time will be broken down according to the following on time ratio:

### On time ratio

$$\varepsilon = \frac{TVwGef - TRw}{TVxGed - TRw}$$

|               |                                                 |
|---------------|-------------------------------------------------|
| $\varepsilon$ | On time ratio                                   |
| TVwGef        | Current flow temperature setpoint               |
| TRw           | Current room temperature setpoint               |
| TVxGed        | Actual value of the attenuated flow temperature |
| TVKx          | Actual value of cascade flow temperature (B10)  |

### → Note

In the case of a single boiler plant without a cascade flow temperature sensor (B10), the boiler temperature is used in place of the actual value of the cascade flow temperature (TVKx).

### Running time

Multiplication of the on time ratio by the cycling period (10 minutes) gives the number of minutes for which the pump runs.

This means that with an on time ratio  $\varepsilon$  of 0.6, the pump runs for 6 minutes and is then switched off for the remaining 4 minutes of the cycling period.

Limitation

---

The pump's running time is set to a minimum of 3 minutes.

The pump's off time is set to a minimum of 2 minutes.

Also, the pump will be activated and deactivated at the following switching points:

- Pump continuously ON  $TVKxGed \leq TVwGef$  ( $\epsilon \geq 1$ )
- Pump continuously OFF  $TVwGef \leq TRw < TVxGed$

→ Important

The function of a room temperature sensor - if present - overrides that of the overtemperature protection.

## 5.11 Heat gains

---

**Benefit**

- To save energy, heat gains are taken into consideration

---

**Description**

This setting takes into account potential heat gains from machines, pieces of equipment, or other constant heat sources, that might adversely affect accurate control. The value will change when the heating curve adaption is activated.

---

**Setting**

1. Press the line selection buttons to select line 35<sub>OEM</sub>.
2. Press the plus / minus buttons to set the effect of heat gains.



---

| <i>Setting range</i> | <i>Unit</i> | <i>Factory setting</i> |
|----------------------|-------------|------------------------|
| -2...+4              | °C          | 0                      |

---

**Effect**

The setting compensates the sum of all constant heat gains as follows:

Increase: For more compensation  
In the case of significant heat sources

Decrease: For less compensation  
In the case of less significant heat sources

The setting in °C corresponds to the temperature differential that would result if the room was solely heated by the heat gains.

## 5.12 Adaptation sensitivity 1

### Benefit

- Adaptation of the heating curve in function of the outside temperature

### Description

Adaptation sensitivity 1 serves for calculating the adaptation of the heating curve in the temperature range 4 to 12 °C (also refer to section "Adaptation of heating curve, line 106").

### Setting

1. Press the line selection buttons to select line 36<sub>OEM</sub>.
2. Press the plus / minus buttons to adjust adaptation sensitivity 1.

**36**

| <i>Display</i> | <i>Factory setting</i> |
|----------------|------------------------|
| 1...15         | 15                     |

The level of adaptation sensitivity is automatically adapted by the controller and, therefore, need not be manually adjusted.

### Effect

The heating curve in the temperature range 4 to 12 °C will be differently adapted, depending on the level of adaptation sensitivity 1.

Increase: More adaptation

Decrease: Less adaptation

### Reduction

Each time a significant adaptation of the heating curve **between** 4 and 12 °C (ZAF1) has taken place, adaptation sensitivity 1 will automatically be reduced by one step. This means that the extent of adaptation and thus the readjustment of the slope and the heating curve's parallel displacement will gradually be reduced .

### → Note

When readjusting the slope of the heating curve (line 17), the adaptation sensitivity will automatically be reset to the factory-set value.

### Diagram

Refer to the next section "Adaptation sensitivity 2".

### → Note

For more detailed information about the effects, refer to operating line "Adaptation of heating curve" (line 106).

## 5.13 Adaptation sensitivity 2

### Benefit

- Adaptation of the heating curve in function of the outside temperature

### Description

Adaptation sensitivity 2 serves for adapting the heating curve in the temperature range **below 4 °C** (also refer to section "Adaptation of heating curve", line 106).

### Setting

1. Press the line selection buttons to select line 37<sub>OEM</sub>.
2. Press the plus / minus buttons to adjust the adaptation sensitivity.

37

| Setting range | Unit | Factory setting |
|---------------|------|-----------------|
| 1...15        | -    | 15              |

The level of adaptation sensitivity is automatically adapted by the controller and, therefore, need not be manually adjusted.

### Effect

The heating curve in the temperature range below 4 °C will be adapted differently, depending on the level of adaptation sensitivity 2.

Increase: More adaptation

Decrease: Less adaptation

### Reduction

Each time a significant adaptation of the heating curve **below 4°C** (ZAF2) has taken place, adaptation sensitivity 2 will automatically be reduced by one step. This means that the extent of adaptation and thus the readjustment of the heating curve's slope will gradually be reduced.

### → Note

When readjusting the slope of the heating curve (line 17), the adaptation sensitivity will automatically be reset to the factory-set value.

### Diagram

Example using a nominal room temperature setpoint of 20 °C:

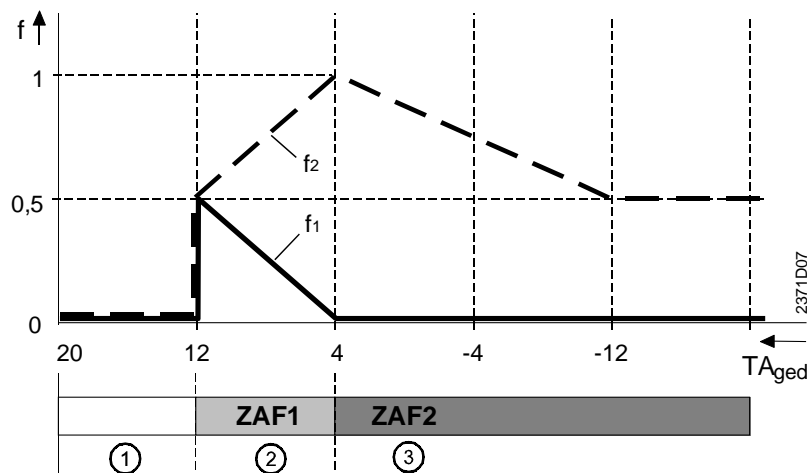

f Factor  
 f1 Factor for parallel displacement  
 f2 Factor for slope  
 TAged Attenuated outside temperature  
 ZAF1 Adaptation sensitivity 1 (line 36<sub>OEM</sub>)  
 ZAF2 Adaptation sensitivity 2 (line 37<sub>OEM</sub>)

### → Note

For more detailed information about the effects, refer to operating line "Adaptation of heating curve" (line 106).

## D.h.w. values OEM

### 5.14 Maximum nominal setpoint of d.h.w. temperature

#### Benefits

- Setting can be limited by the end-user
- Reduced risk of scalding
- Minimized proneness to lime build-up

#### Description

Function for limiting the nominal setpoint of the d.h.w. temperature.

#### Setting

40

1. Press the line selection buttons to select line 40<sub>OEM</sub>.
2. Press the plus / minus buttons to adjust the nominal setpoint of the d.h.w. temperature.

| <u>Setting range</u> | <u>Unit</u> | <u>Factory setting</u> |
|----------------------|-------------|------------------------|
| 8...80               | °C          | 60                     |

#### Effect

The setting will ensure maximum limitation of the nominal d.h.w. temperature setpoint (setting on line 13).

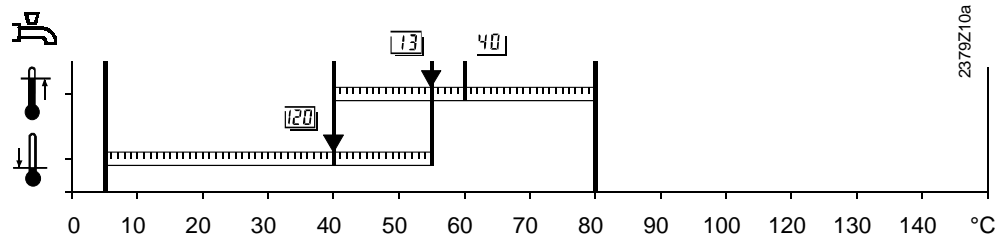

- 13 Setting "Nominal setpoint of d.h.w. temperature"  
120 Setting "Reduced setpoint of d.h.w. temperature"  
40<sub>OEM</sub> Setting "Maximum nominal setpoint of d.h.w. temperature"

## 5.15 Switching differential of d.h.w. temperature

### Benefit

- Optimum frequency of d.h.w. heating

### Description

D.h.w. control is in the form of a two-position controller with an adjustable switching differential.

### → Note

The switching differential for d.h.w. control has no impact on d.h.w. with a control thermostat or changeover valve (via BMU).

### Setting

1. Press the line selection buttons to select line 41<sub>OEM</sub>.
2. Press the plus / minus buttons to adjust the switching differential for d.h.w.

41

| <i>Setting range</i> | <i>Unit</i> | <i>Factory setting</i> |
|----------------------|-------------|------------------------|
| 0...20               | °C (K)      | 5                      |

### Effect

The setting will change the switching differential of the d.h.w. temperature control.

Entry:

Increase: Switching differential will become larger  
Fewer and longer heating up times, larger temperature variations

Decrease: Switching differential will become smaller  
More frequent and shorter heating up times, smaller temperature variations

### D.h.w. temperature control

Two-position control heats the d.h.w. at certain intervals. The duration of d.h.w. heating depends mainly on the storage tank's capacity and water volume and the amount of d.h.w. currently required.

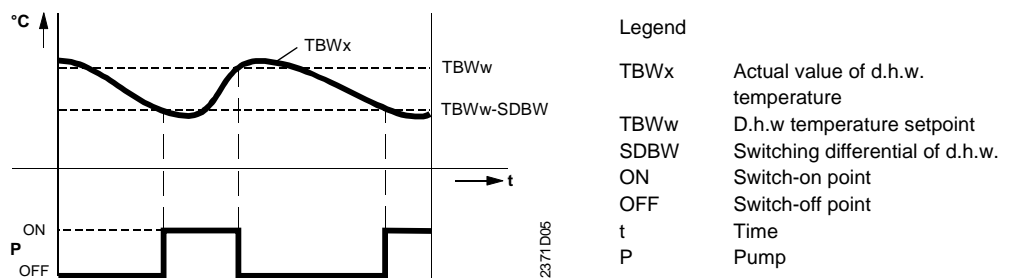

Switching differential

|             |                        |
|-------------|------------------------|
| D.h.w. ON:  | $TBW_x = TBW_w - SDBW$ |
| D.h.w. OFF: | $TBW_x = TBW_w$        |

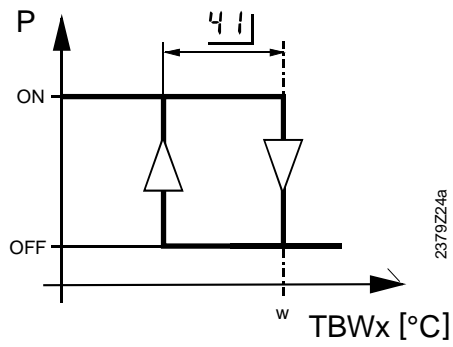

- TBW<sub>x</sub> Actual value of d.h.w. temperature
- TBW<sub>w</sub> Setpoint of d.h.w. temperature
- SDBW Switching differential of d.h.w. (Δ)
- P Pump (ON / OFF)
- w Setpoint
- △ Switch-on point
- ▽ Switch-off point

## 5.16 Legionella function

### Benefit

- Potential legionella viruses in the d.h.w. will be killed at regular intervals.

### Description

The legionella function ensures that the d.h.w. in the storage tank will periodically be raised to a temperature of at least 60 °C, thus making certain that potential legionella viruses will be killed.

### Setting

1. Press the line selection buttons to select line 42<sub>OEM</sub>.
2. Press the plus / minus buttons to activate or deactivate the legionella function.

42

| <u>Setting range</u> | <u>Unit</u> | <u>Factory setting</u> |
|----------------------|-------------|------------------------|
| 0 / 1                | Increment   | 1                      |

### Effect

The setting activates or deactivates the legionella function.

Entry:

- 0** OFF: Function not active.
- 1** ON: The function will be activated every Monday morning when d.h.w. is heated up for the first time and lasts a maximum of 2.5 hours. The d.h.w. is heated up to the adjusted legionella setpoint. Also refer to line 43<sub>OEM</sub>.

### → Notes

This function is possible only when d.h.w. heating is released by the d.h.w. heating program.

If the legionella function is aborted during the usual time (on Mondays), it will be repeated the next time the d.h.w. setpoint is changed.

## 5.17 Setpoint of legionella function

### Benefit

- Adjustable temperature level to kill legionella viruses

### Description

The setpoint of the legionella function is an adjustable temperature level to which the d.h.w. temperature is raised when the legionella function is activated (also refer to section "Legionella function"). For details, also refer to "Legionella function", line 42<sub>OEM</sub>.

### Setting

1. Press the line selection buttons to select line 43<sub>OEM</sub>.
2. Press the plus / minus buttons to adjust the required setpoint.

43

| <u>Setting range</u> | <u>Unit</u> | <u>Factory setting</u> |
|----------------------|-------------|------------------------|
| 8...95               | °C          | 65                     |

### Effect

The setting changes the d.h.w. setpoint during the period of time the d.h.w. is heated up as a result of the legionella function.

## 5.18 Protection against discharging of d.h.w.

**Benefit**

- Prevents inadvertent discharging of the d.h.w. storage tank via the heating system

**Description**

Prevents inadvertent discharging of the d.h.w. storage tank by cold water from the heating circuit.

**Setting**

**44**

- Press the line selection buttons to select line 44<sub>OEM</sub>.
- Press the plus / minus buttons to activate or deactivate the protection against discharging.

| <i>Setting range</i> | <i>Unit</i> | <i>Factory setting</i> |
|----------------------|-------------|------------------------|
| 0...2                | -           | 2                      |

**Effect**

The setting activates or deactivates the protection against discharging:

- 0 Protection against discharging is **not** active
- 1 Protection against discharging is **active**
- 2 Protection against discharging is **active** only when heat generation is locked

When protection against discharging of the d.h.w. is active, the boost of the flow temperature (operating line 126) is checked during the heating cycle:

- If at least half the boost value is reached, d.h.w. heating will be **released**
- If the boost value is less than 1/8 of the value set, d.h.w. heating will **not** be released

→ **Note**

Setting 1 may be used only if the cascade return temperature sensor is connected.

## Cascade settings OEM

### 5.19 Cascade management strategy

#### Benefits

- Selection of required type of lead boiler operation.
- Combination with optimum running time strategy.

#### Description

For the plant configuration used, this setting represents an optimum combination of lead boiler operation and running time strategy.

#### Setting

The icon shows the number '50' inside a square frame with a horizontal line below it, representing the setting value.

1. Press the line selection buttons to select line 50<sub>OEM</sub>.
2. Press the plus / minus buttons to select the required combination of lead boiler operation and running time strategy.

| <u>Setting range</u> | <u>Unit</u> | <u>Factory setting</u> |
|----------------------|-------------|------------------------|
| 1...6                | 1           | 2                      |

There is a total of two types of lead boiler operation and three running time strategies available. The six combinations are assigned as follows:

| <u>Settings (Combination)</u> | <u>Type of lead boiler operation</u> | <u>Running time strategy</u> |
|-------------------------------|--------------------------------------|------------------------------|
| 1                             | autonomous                           | 1                            |
| 2                             | autonomous                           | 2                            |
| 3                             | autonomous                           | 3                            |
| 4                             | linked                               | 1                            |
| 5 (factory setting)           | linked                               | 2                            |
| 6                             | linked                               | 3                            |

#### → Note

Proceed as follows to make the required setting:

- First, determine the required type of lead boiler operation
- Determine the required running time strategy
- Use the above table to choose the setting required for your application

## 5.19.1 Type of lead boiler operation

### General

The type of lead boiler operation describes the way the individual boilers in the cascade are controlled.

### Autonomous:

The RVA47.320 delivers a boiler temperature setpoint to the BMUs. The released BMUs then control their output autonomously between 0 and 100 % in order to reach the preset boiler temperature setpoint.

### Example:

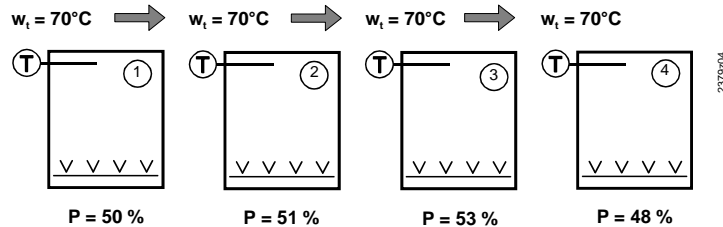

$w_t$  = Boiler temperature setpoint  
 $P$  = Actual output

It is thus possible that individual boilers will be operated outside their output range. The average actual output is within the defined output range, however (for exceptions, refer to lines 51 and 52).

### Linked:

A differentiation is made between lead boiler and lag boilers. The RVA47.320 delivers a temperature setpoint to the lead boiler, which translates it into output. The lag boilers take this output as maximum limitation of output, thus following the lead boiler.

### Example:

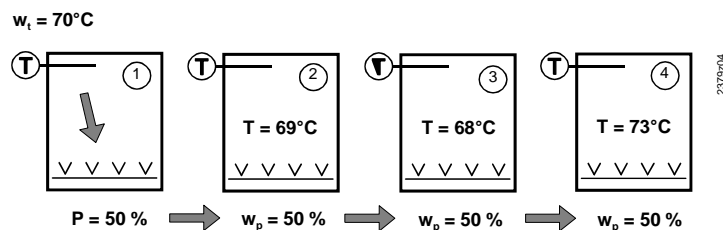

$w_t$  = Boiler temperature setpoint for lead boiler  
 $w_p$  = Nominal output setpoint for BMUs 1 - 4  
 $P$  = Actual output  
 $T$  = Actual temperature

This means that all boilers will be operated within the defined output range (for exceptions, refer to pages 39 and 41).

### → Note

In the case of linked lead boiler operation, the controller considers the ratio of the nominal BMU outputs and matches the speed of lag boiler operation accordingly.

## 5.19.2 Running time strategies

### General

The running time strategy defines the criteria for the switching on / off of the lag boilers. It is determined by the following parameters:

- Nominal output of BMU 1 - 4 See line 91 -94
- Entry of minimum limit of output range (Pmin) See line 10<sub>OEM</sub>
- Entry of maximum limit of output range (Pmax) See line 52<sub>OEM</sub>

The RVA47.320 initiates changeover only when it leads to a valid operational status while taking the above parameters into consideration.

### → Notes

The following parameters also have an impact on the function:

- Delayed switching on of BMU see line 133
- Restart lock for BMU see line 134

For stability reasons, each BMU added to the cascade first runs on the basic stage for about one minute on completion of which it will be released for modulating control to deliver the output required.

### → Important

The running time strategies described below become active only when the flow temperature setpoint is reached. During the heating up time (e.g. after night setback), the boilers required are run up to the maximum released output as quickly as possible (short heating up time).

### Strategy 1:

Additional boilers are switched on as late as possible and switched off again as early as possible. Hence, the aim is to have the **smallest possible number of boilers in operation**, or to obtain short running times for additional boilers.

Example of three boilers with an output range of 20 - 80 %:

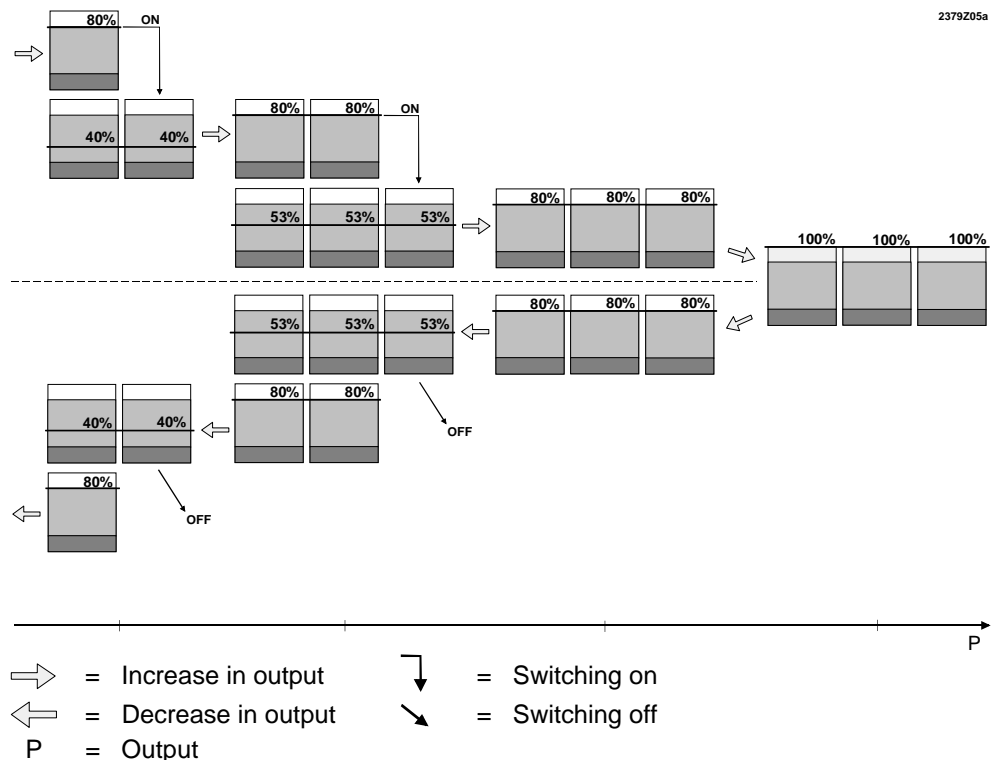

**Strategy 2:**

Additional boilers are switched on as late as possible and switched off again as late as possible. Hence, the aim is to obtain the **smallest possible number of switching on / off cycles** for the boilers.

Example of three boilers with an output range of 20 - 80 %:

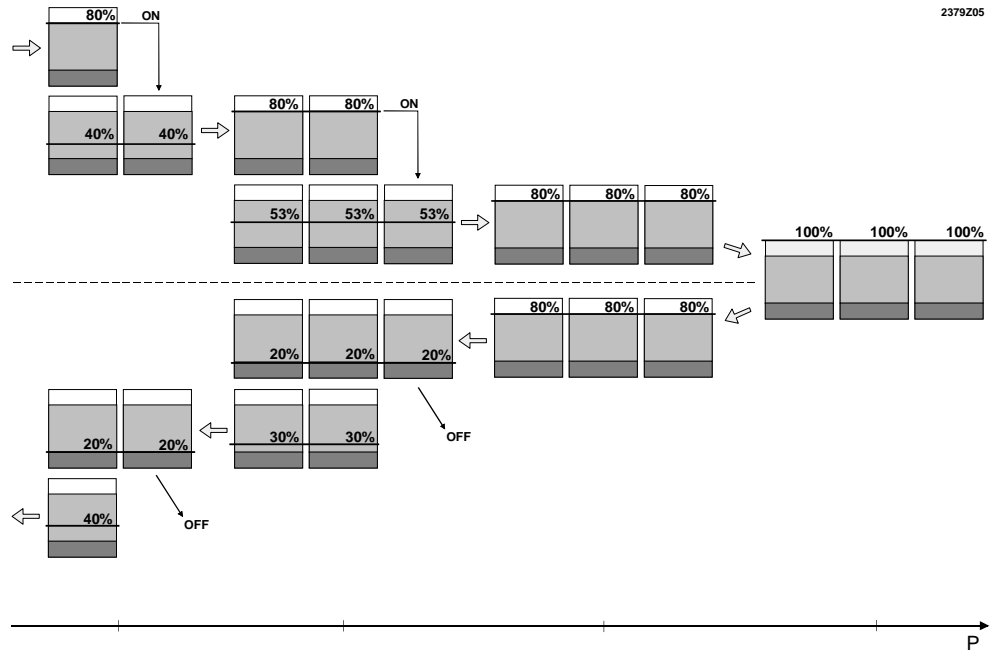

**Strategy 3:**

Additional boilers are switched on as early as possible and switched off as late as possible. Hence, the aim is to have the **highest possible number of boilers in operation**, or to obtain long running times for additional boilers.

Example of three boilers with an output range of 20 - 80 %:

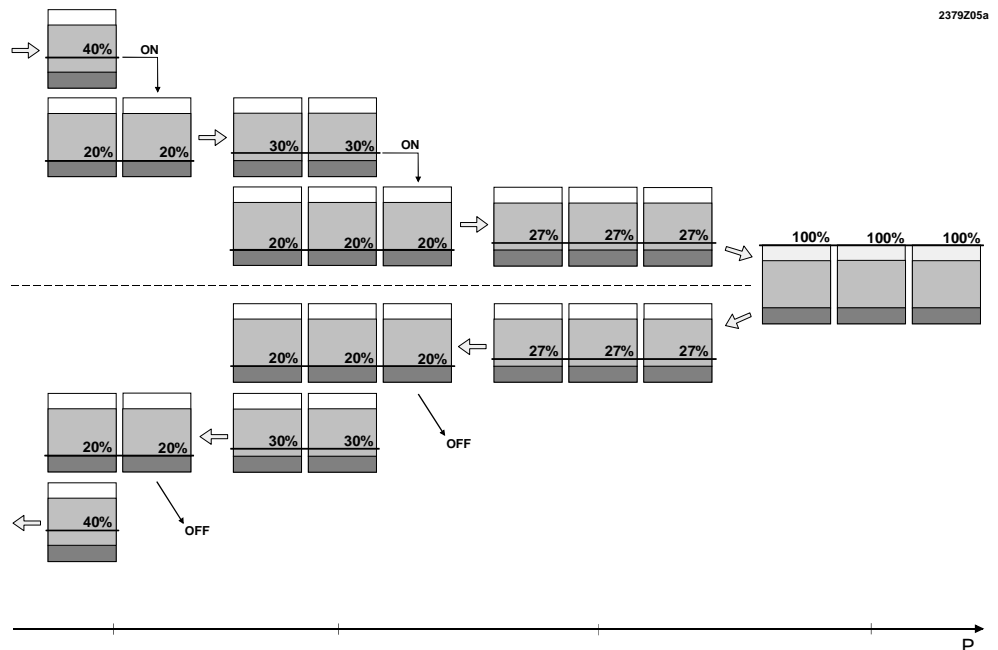

- ⇒ = Increase in output
- ⇐ = Decrease in output
- P = OutputLeistung
- ↙ = Switching onZuschaltung
- ↘ = Switching offWegschaltung

## 5.20 Minimum limit of output range (Pmin)

### Benefit

- The minimum output of the boilers controlled by the BMUs can be defined.

### Description

Defines the minimum limit of the optimum output range used by the BMUs.

### Setting

- Press the line selection buttons to select line 51<sub>OEM</sub>.
- Press the plus / minus buttons to set the minimum limitation of the output.

51

| <i>Setting range</i> | <i>Unit</i> | <i>Factory setting</i> |
|----------------------|-------------|------------------------|
| 5...Pmax             | %           | 40                     |

Pmax. = upper limit of output range (operating line 52)

### → Note

Typically, the set minimum limitation of the output lies above the lowest basic stage of all BMUs. A lower setting causes several BMUs to cycle. Do not use lower settings without having tested them in practical operation.

### Effect

The setting defines the minimum limit of the output range within which the BMUs are controlled. The value is used as the switch-on or switch-off criterion according to the selected running time strategy (refer to page 146).

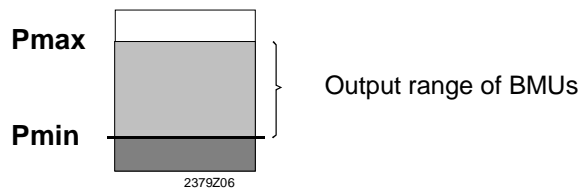

The minimum limit of the output range is crossed only in exceptional cases, e.g. when the setting of the value is too high, or when, due to the BMUs' output ratio, an invalid operational status would result after changeover.

## 5.21 Maximum limit of output range (Pmax)

### Benefit

- The maximum output of the BMUs can be defined.

### Description

Defines the maximum limit of the optimum output range used by the BMUs.

### Setting

- Press the line selection buttons to select operating line 52<sub>OEM</sub>.
- Press the plus / minus buttons to set the maximum limitation of the output.

52

| <i>Setting range</i> | <i>Unit</i> | <i>Factory setting</i> |
|----------------------|-------------|------------------------|
| Pmin...100           | %           | 90                     |

Pmin. = minimum limit of output range (operating line 51)

### Effect

The setting defines the maximum limit of the output range within which the BMUs are controlled. The value is used as the switch-on or switch-off criterion according to the selected running time strategy (refer to page 146).

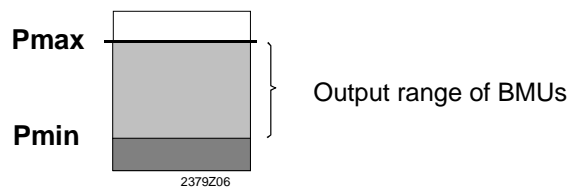

The maximum limit of the output range (when <100 %) is crossed only when all available BMUs run at Pmax and there is still demand for heat.

Otherwise, crossing only takes place in exceptional cases, e.g. when the setting of the value is too low, or when, due to the BMUs output ratio, an invalid operational status would result after changeover.

When using a setting of 100 %, the value will of course never be exceeded.

## 5.22 Mandatory time on the basic stage

---

### Benefit

- The minimum running time on the basic stage can be defined
- 

### Description

This function allows the minimum running time on the basic stage to be set. This enables the controller to operate smoothly even if BMUs of very high capacity are used.

---

### Setting

1. Press the line selection buttons to select operating line 56<sub>OEM</sub>.
2. Press the plus / minus buttons to adjust the mandatory time on the basic stage.

**56**

| <i>Setting range</i> | <i>Unit</i> | <i>Factory setting</i> |
|----------------------|-------------|------------------------|
| 10...1200            | s           | 60                     |

---

### Effect

When started up, each BMU is operated on the basic stage for the period of time adjusted here. The BMU will be released for modulation only when this time has elapsed. This period of time enables the controller to analyse the current operational status and then plan the next steps.

### → Note

When using heat generating equipment of very high capacity, the longer time leads to a more stable (slower) operating performance.

## 5.23 Minimum temperature differential at the pressureless header

### Benefits

- Detection of a too high flow rate on the heat generation side.
- Avoiding excessive return temperatures.

### Description

An excessive flow rate on the heat generation side and the resulting increase of the return temperature is quickly detected and, if necessary, offset by shutting down one of the BMUs.

### Setting

60

1. Press the line selection buttons to select line 60<sub>OEM</sub>.
2. Press the plus / minus buttons to set the minimum temperature differential.

| Setting range | Unit   | Factory setting |
|---------------|--------|-----------------|
| 0...20        | K (°C) | 4               |

### Effect

The minimum temperature differential at the pressureless header prevents the return temperature from exceeding a certain level.

The setting is only active when running time strategy 2 or 3 is selected (see page 35). With running time strategy 1, the function is inactive.

When the return temperature rises to a level half the switching differential below the flow temperature (MTS/2 / point a), the selected running time strategy 2 or 3 is switched over to running time strategy 1 and the boiler temperature setpoint boosts will be reset. This means that one of the BMUs is shut down as soon as possible.

If the return temperature moves away from the flow temperature by one full switching differential MTS (point b), changeover is cancelled again. This means that running time strategy 1 switches back to the previous running time strategy 2 or 3.

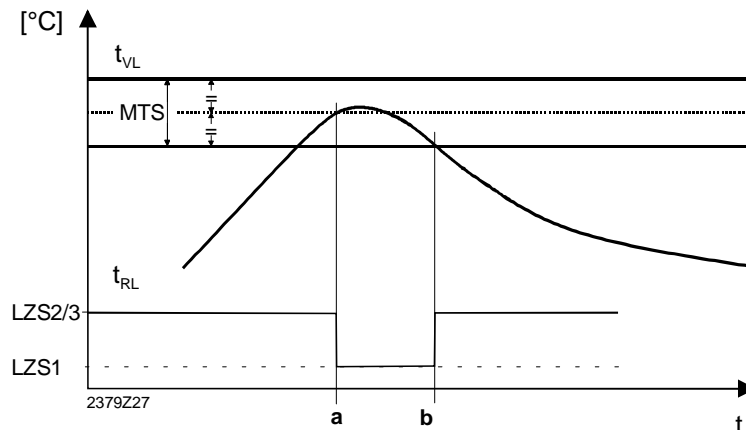

|          |                                                             |
|----------|-------------------------------------------------------------|
| $t_{VL}$ | Cascade flow temperature (B10)                              |
| $t_{RL}$ | Cascade return temperature (B70)                            |
| MTS      | Minimum temperature differential at the pressureless header |
| LZS1-3   | Running time strategy 1 - 3                                 |
| a / b    | Changeover points of running time strategy                  |

## Configuration of plant

### 5.24 Continuous display

---

**Benefit**

- Selection of value for the continuous display.

---

**Description**

Determines to kind of information to appear on the continuous display.

---

**Setting**

- 0 Press the line selection buttons to select operating line 90<sub>OEM</sub>.  
1 Press the plus / minus buttons to select the required continuous display.

90

| <u>Setting range</u> | <u>Unit</u> | <u>Factory setting</u> |
|----------------------|-------------|------------------------|
| 0 / 1                | -           | 0                      |

---

**Effect**

This setting changes the continuous display of the device. It appears when no operating line is selected.

- 0 Day / time of day  
The continuous display shows the weekday (1...7 = Mo...Su) and the time of day.
- 1 Cascade flow temperature sensor (common flow temperature sensor)  
The continuous display shows the temperature measured with the cascade flow temperature sensor (B10)

**→ Caution!**

When connecting several BMUs to the controller, the continuous display always shows the cascade flow temperature. In that case, setting 0 can be no longer selected.

## General values

### 5.25 Software version

| <b>Benefit</b>     | <ul style="list-style-type: none"><li>• Straightforward display of software version in use, without removing the controller</li></ul>                                                                                                                                                                                                 |                |             |               |        |
|--------------------|---------------------------------------------------------------------------------------------------------------------------------------------------------------------------------------------------------------------------------------------------------------------------------------------------------------------------------------|----------------|-------------|---------------|--------|
| <b>Description</b> | The software version installed represents the state of the software available at the time the controller was produced.                                                                                                                                                                                                                |                |             |               |        |
| <b>Setting</b>     | <ol style="list-style-type: none"><li>1. Press the line selection buttons to select line 91<sub>OEM</sub>.</li><li>2. No setting can be made with the plus / minus buttons.</li></ol> <table><thead><tr><th><i>Display</i></th><th><i>Unit</i></th></tr></thead><tbody><tr><td>00.0 ... 99.9</td><td>Digits</td></tr></tbody></table> | <i>Display</i> | <i>Unit</i> | 00.0 ... 99.9 | Digits |
| <i>Display</i>     | <i>Unit</i>                                                                                                                                                                                                                                                                                                                           |                |             |               |        |
| 00.0 ... 99.9      | Digits                                                                                                                                                                                                                                                                                                                                |                |             |               |        |
|                    |                                                                                                                                                                                                                                                                                                                                       |                |             |               |        |
| <b>Effect</b>      | The software version will automatically be displayed on this line.<br><br>Example:        01.0<br>The first two digits give the software version        (01.)<br>The third digit gives the software revision        (.0)                                                                                                              |                |             |               |        |

### 5.26 Number of device operating hours

| <b>Benefit</b>     | <ul style="list-style-type: none"><li>• Display of the number of device operating hours</li></ul>                                                                                                                                                                                                                                                                 |                |             |              |   |
|--------------------|-------------------------------------------------------------------------------------------------------------------------------------------------------------------------------------------------------------------------------------------------------------------------------------------------------------------------------------------------------------------|----------------|-------------|--------------|---|
| <b>Description</b> | Here, you can read the number of hours the controller has been in operation                                                                                                                                                                                                                                                                                       |                |             |              |   |
| <b>Setting</b>     | <ol style="list-style-type: none"><li>1. Press the line selection buttons to select operating line 92<sub>OEM</sub>.</li><li>2. No setting can be made with the plus / minus buttons.</li></ol> <table><thead><tr><th><i>Display</i></th><th><i>Unit</i></th></tr></thead><tbody><tr><td>0... 500'000</td><td>h</td></tr></tbody></table>                         | <i>Display</i> | <i>Unit</i> | 0... 500'000 | h |
| <i>Display</i>     | <i>Unit</i>                                                                                                                                                                                                                                                                                                                                                       |                |             |              |   |
| 0... 500'000       | h                                                                                                                                                                                                                                                                                                                                                                 |                |             |              |   |
|                    |                                                                                                                                                                                                                                                                                                                                                                   |                |             |              |   |
| <b>Effect</b>      | The number of operating hours since the controller was first commissioned will automatically be displayed on this line.<br><br>The hours considered as operating hours are those during which power was supplied to the controller, that is, including the periods of time with no effective heating operation.<br>The number of operating hours cannot be reset. |                |             |              |   |

## 6 Functions with no settings

---

### Introduction

The functions described below require no settings. They are performed automatically but have an effect on the plant.

For the rectification of faults, planning and plant maintenance, it may therefore be very advantageous to know about their impact on the plant.

### 6.1 Chimney sweep

---

#### Benefit

- Produces the operational status required for flue gas measurements.
- 

#### Description

No chimney sweep function can be triggered on the controller itself. The chimney sweep function is activated directly on the respective BMU.

---

#### Effect

As soon as the chimney sweep function is triggered on one of the BMUs of the cascade, the BMU transmits the signal to the controller, which shuts down all other BMUs. The controller allows the boiler temperature to rise to a level of 64 °C, which is required to make flue gas measurements, then maintaining that temperature level by enforcing heat consumption of both the heating circuits and d.h.w.

This action is independent of whether a lead or lag boiler is involved.

By deactivating the chimney sweep function on the BMU, or on completion of a period of time to be adjusted on the BMU, the controller returns to its initial operational status.

#### → Note

For information about the activation of the chimney sweep function and other information, refer to the technical documentation of the type of BMU used.

## 6.2 Generation of boiler temperature setpoint

|                    |                                                                                                                                                                                                                                                                                                                                                                                                                                                      |
|--------------------|------------------------------------------------------------------------------------------------------------------------------------------------------------------------------------------------------------------------------------------------------------------------------------------------------------------------------------------------------------------------------------------------------------------------------------------------------|
| <b>Benefit</b>     | <ul style="list-style-type: none"> <li>Demand-dependent control of the burner</li> </ul>                                                                                                                                                                                                                                                                                                                                                             |
| <b>Description</b> | The various heating circuits require different flow temperature setpoints depending on the demand for heat. However, since the boiler temperature control can consider only one setpoint, a selection is made.                                                                                                                                                                                                                                       |
| <b>Process</b>     | <p>Generally, the demand for the highest setpoint required by a consumer (e.g. by a heating circuit) generates the current boiler temperature setpoint.</p> <p>The setpoint requirements considered stem from both controller-internal setpoints (heating circuit or input H1) and setpoints transmitted via LPB.</p> <p>Auxiliary functions, such as setpoint boosts and the like, are included in the setpoints actually demanded at the time.</p> |
| <b>Exception</b>   | A demand for d.h.w. has priority over all other setpoint requirements, which means that the required d.h.w. setpoint will be maintained, even if it is lower than that called for by a heating circuit.                                                                                                                                                                                                                                              |
| <b>Effect</b>      | The boiler temperature is maintained at the highest setpoint currently demanded - unless d.h.w. is required.                                                                                                                                                                                                                                                                                                                                         |

Example

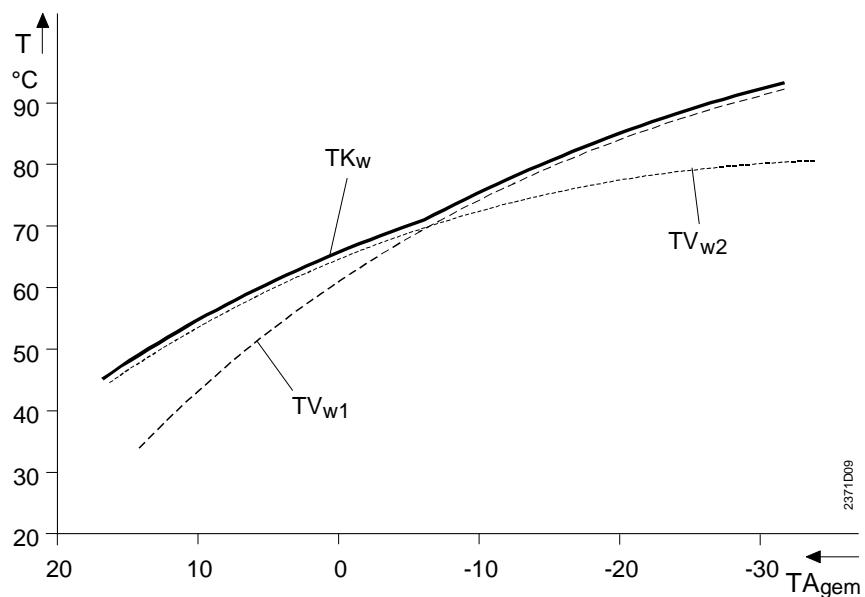

|                  |                                                                                                  |
|------------------|--------------------------------------------------------------------------------------------------|
| TK <sub>w</sub>  | Boiler temperature setpoint                                                                      |
| TV <sub>w1</sub> | Flow temperature setpoint of controller-internal heating circuit 2 (incl. setpoint boost if any) |
| TV <sub>w2</sub> | Flow temperature setpoint of a controller-external heating circuit (incl. setpoint boost if any) |

## 6.3 Automatic 24-hour heating limit

---

### Benefits

- Automatic shutdown of heating
  - Saving energy without sacrificing comfort
- 

### Description

This is a fast-acting savings function since the heating is switched off when there is no more demand for heat. Economical operation is ensured throughout the year, especially during intermediate seasons. Manual switching off is no longer required.



### → Notes

- The automatic 24-hour heating limit does not function in continuous operation 
- When the automatic 24-hour heating limit is active, the pointer on the display under the current operating mode flashes.

### 6.3.1 Without room temperature influence

---

#### Introduction

If **no** room unit is connected, the room temperature setpoint will **not** be readjusted by the room temperature influence. In that case, the automatic 24-hour heating limit operates according to the selected setpoint of   or .

#### Process

The temperature basis used for this function are the values of the composite outside temperature and the current room temperature setpoint.

For switching on / off, a fixed switching differential of 2 °C is used.

#### Switching off

When the composite outside temperature exceeds the current room temperature setpoint, the heating will be switched off.

$$\text{Heating's switch-off point: } T_{\text{Agem}} = TR_w$$

#### Switching on

When the composite outside temperature falls below the current room temperature setpoint by more than 2 °C, the heating will be switched on.

$$\text{Heating's switch-on point: } T_{\text{Agem}} = TR_w - 2 \text{ °C}$$

Diagram

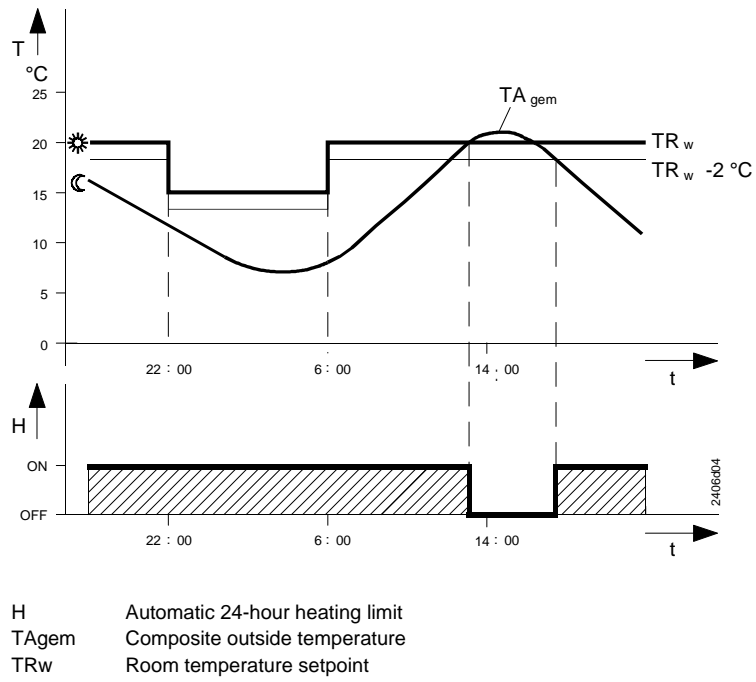

Effect

During the periods of time the automatic 24-hour heating limit is active, the heating will automatically be switched off.

## 6.3.2 With room temperature influence

### Introduction

The automatic 24-hour heating limit operates depending on the current room temperature setpoint. If a room unit is connected, the room temperature influence continuously readjusts the room temperature setpoint.

This means that the automatic 24-hour heating limit differs when the room temperature influence is used.

### Process

The temperature basis used for this function are the values of the composite outside temperature and those for the current setpoint which may have been readjusted by the room temperature influence.

Hence, the "current setpoint" is the readjusted setpoint (TRwk), which is used as a basis.

For switching on / off, a fixed switching differential of 2 °C is used.

### Switching off

When the composite outside temperature exceeds the current room temperature setpoint, the heating will be switched off.

$$\text{Heating's switch-off point: } T_{Agem} = TR_{wk}$$

### Switching on

When the composite outside temperature falls below the current room temperature setpoint by more than 2 °C, the heating will be switched on.

$$\text{Heating's switch-on point: } T_{Agem} = TR_{wk} - 2 \text{ °C}$$

### Diagram

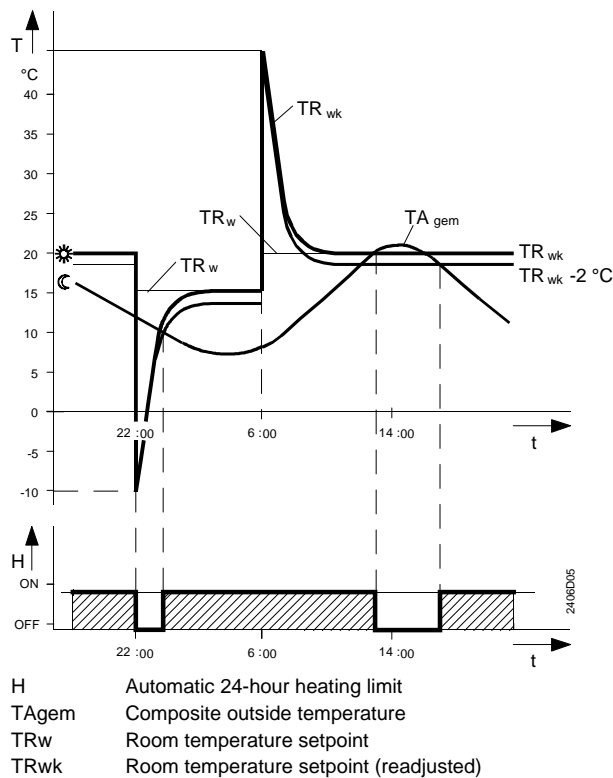

### Effect

During the periods of time the automatic 24-hour heating limit is active, the heating will automatically be switched off.

## 6.4 Quick setback with a room temperature sensor

### Benefit

- Making use of the building's thermal storage capacity

### Description

Quick setback is dependent on whether or not a room temperature sensor is used. A differentiation must therefore be made between quick setback with or without room temperature sensor.

### → Important

This process has an impact only when a room temperature sensor is used.

### Process

Quick setback is started as soon as a change to a lower room temperature setpoint takes place (e.g. switching times in automatic mode).

Quick setback is terminated as soon as the actual room temperature reaches the level of the respective room temperature setpoint ( $TR_x = TR_w$ ).

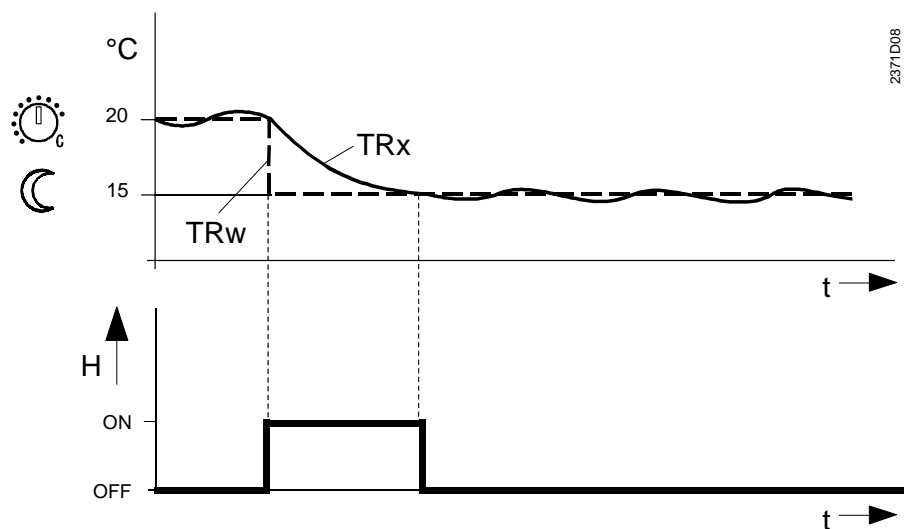

TR<sub>x</sub> Actual value of room temperature  
 TR<sub>w</sub> Room temperature setpoint  
 H Quick setback

### Effect

Due to the readjustment of the room temperature setpoint, the heating circuit pump will be switched off until the quick setback process is terminated. This means that the room temperature falls quicker since the supply of heat from the boiler is cut off.

### → Note

If no room temperature sensor is connected, quick setback will not be accomplished through this process. For details, refer to section "Quick setback constant", operating line 31<sub>OEM</sub>.

## 6.5 D.h.w. push

### Benefit

- Availability of d.h.w. is also ensured during non-occupancy times

### Description

If, due to unexpected demand, the d.h.w. storage tank is emptied, the d.h.w. push provides one-time charging of the storage tank until the nominal d.h.w. temperature setpoint is reached.

### Process

The d.h.w. push is triggered as soon as the actual d.h.w. temperature falls below the reduced d.h.w. setpoint (line 120) by more than twice the switching differential (line ).

$$TBW_x < TBWR - 2 \text{ SDBW}$$

### Effect

When the d.h.w. push is triggered, the storage tank is charged once until the nominal d.h.w. temperature setpoint (line 13) is reached.

Then, normal operation according to the d.h.w. heating program is resumed.

### Example

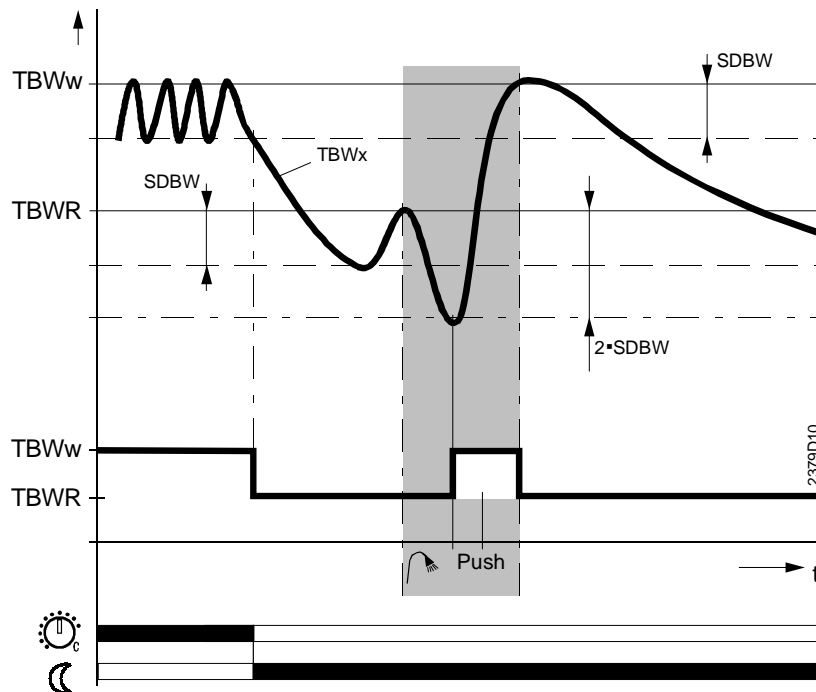

SDBW Switching differential of d.h.w.  
 TBWw Nominal setpoint of d.h.w. temperature  
 TBWR Reduced setpoint of d.h.w. temperature

## 6.6 Pump kick

---

|                    |                                                                                                                                                                                                                                                          |
|--------------------|----------------------------------------------------------------------------------------------------------------------------------------------------------------------------------------------------------------------------------------------------------|
| <b>Benefit</b>     | <ul style="list-style-type: none"><li>• No seizing of pumps</li></ul>                                                                                                                                                                                    |
| <b>Description</b> | The pump kick is a protective function aimed at preventing the pumps from seizing.                                                                                                                                                                       |
| <b>Process</b>     | <p>Every Friday at 10:00 h, the pumps connected directly to the RVA47.320 are activated for 30 seconds, one by one at an interval of one minute.</p> <hr/> <p>The pump kick is activated without giving consideration to any of the other functions.</p> |
| <b>Effect</b>      | During the periods of time pump kick is activated, the water circulates. The mechanical parts of the pumps will be purged, thus preventing the pumps from seizing.                                                                                       |
| <b>→ Note</b>      | The kick of the d.h.w. pump is the last pump kick made in order to prevent heat from being transferred from the d.h.w. storage tank to the heating system.                                                                                               |

## 6.7 Protection against discharging after d.h.w. heating

---

|                    |                                                                                                                                                                                                                                                                                                                                     |
|--------------------|-------------------------------------------------------------------------------------------------------------------------------------------------------------------------------------------------------------------------------------------------------------------------------------------------------------------------------------|
| <b>Benefit</b>     | <ul style="list-style-type: none"><li>• Inadvertent discharging of the d.h.w. storage tank will be prevented</li></ul>                                                                                                                                                                                                              |
| <b>Description</b> | The “Protection against discharging after d.h.w. heating” prevents inadvertent discharging of the d.h.w. storage tank resulting from the pump overrun. Together with “Protection against discharging during d.h.w. heating” (operating line 44 <sub>OEM</sub> ), efficient protection against discharging is thus ensured.          |
| <b>Process</b>     | <p>The controller compares the storage tank temperature with the cascade flow temperature (common flow temperature) or, in certain situations, with the boiler temperature.</p> <p>If the cascade temperature (or the boiler temperature) is lower than the storage tank temperature, pump overrun will be stopped prematurely.</p> |

## 6.8 Overview of pump operation

### Benefit

- Straightforward checking of the proper functioning of the various pumps

### Description

Operation of the various pumps depends on a number of factors. To enable you to quickly understand the different interrelationships when commissioning and checking the plant, please make use of the list below. It provides information about the setting combinations (pump settings / demand for heat) at which a pump runs (the meaning of the different pump settings is defined on operating line 95).

| <i>Pumps<br/>Settings</i> | <i>Demand for heat</i>                                                                                 |                                         |                                           |
|---------------------------|--------------------------------------------------------------------------------------------------------|-----------------------------------------|-------------------------------------------|
|                           | <i>via HC:</i>                                                                                         | <i>via input H1:</i>                    | <i>via d.h.w.:</i>                        |
| <b>Q1<br/>Setting 1</b>   | Pump runs when there is demand for heat                                                                | Pump does not run                       | Pump does not run                         |
| <b>Q1<br/>Setting 2</b>   | *Pump runs when there is demand for heat                                                               | Pump runs when there is demand for heat | Pump does not run                         |
| <b>Q1<br/>Setting 3</b>   | *Pump runs when there is demand for heat                                                               | Pump runs when there is demand for heat | * Pump runs when there is demand for heat |
| <b>Q1<br/>Setting 4</b>   | No influence from type of heat demand. Pump runs according to the settings made on operating line 122. |                                         |                                           |
| <b>Q1<br/>Setting 5</b>   | Pump does not run                                                                                      | Pump runs when there is demand for heat | Pump does not run                         |
| <b>Q3<br/>Setting 1</b>   | Pump does not run                                                                                      | Pump does not run                       | Pump runs when there is demand for heat   |

\* = the pump also runs when the demand for heat comes from another controller integrated via LPB

When there is no more demand for heat, the pumps in operation overrun for the period of time set on line "Pump overrun time" ( $t_{OEM}$ ), with the exception of the d.h.w. circulating pump, Q1 setting 4.

There are situations, however, where the pumps (with the exception of pump H1, Q1 setting 5) do not run, for example with:

- Summer / winter changeover
- 24-hour heating limit
- Quick setback
- Room temperature limitation by room sensor

## 6.9 Frost protection

### Benefit

- Ensures that the boiler and d.h.w. temperature will not fall below a certain level

### → Note

In addition to the frost protection modes described here, frost protection for the building and frost protection for the plant, whose parameters can be set, are also active. For details, refer to the description given on lines 15 and 33<sub>OEM</sub>.

### 6.9.1 For the boiler

### Description

The frost protection function for the boilers is integrated in the BMUs. For detailed information, refer to the technical documentation of the product used.  
Informationen darüber entnehmen Sie bitte der Dokumentation des jeweils verwendeten Produktes.

### 6.9.2 For the d.h.w.

### Description

Frost protection for the d.h.w. prevents freeze-ups of the d.h.w. storage tank that is connected directly to the RVA47.320. Whenever the d.h.w. temperature drops excessively, forced charging will be initiated.

### Process

| <i>If...</i>                                                                                                                                                            | <i>then...</i>                                                         |
|-------------------------------------------------------------------------------------------------------------------------------------------------------------------------|------------------------------------------------------------------------|
| the actual value of the d.h.w. temperature falls below 5 °C...<br>(TBW <sub>x</sub> < 5 °C)                                                                             | ... the frost protection function for the d.h.w. becomes <b>active</b> |
| the actual value of the d.h.w. temperature exceeds 5 °C by more than one d.h.w. switching differential (line 41 <sub>OEM</sub> )...<br>(TBW <sub>x</sub> > 5 °C + SDBW) | ... the frost protection function for d.h.w. will be <b>terminated</b> |

### → Notes

- The frost protection setpoint for the d.h.w. is factory-set at 5 °C and cannot be changed
- Pump overrun will be activated when d.h.w. heating is terminated.

### → Important

- The frost protection function only acts on a d.h.w. storage tank connected directly to the RVA47.320. In the case of plant types with d.h.w. heating via BMU, this function must be provided by the BMU.
- The frost protection function is only active when using a temperature sensor. If the d.h.w. is heated with the help of a control thermostat, no frost protection function is possible because there is no actual value of the storage tank temperature.

# 7 Application examples

---

## General

The RVA47.320 can control up to four modulating gas-fired heating boilers. For this purpose, the boilers must be equipped with an appropriate BMU which controls the boiler temperature.

In the controller's internal cascade circuit, the RVA47.320 determines the order the individual BMUs are switched on and off based on the output balance. The boilers are thus switched on and off temperature over- or undershoot. The individual boilers are controlled by the respective BMUs.

Furthermore, the controller can ensure the coordination of additional boiler controllers of a cascade (cascade master function).

D.h.w. heating is provided either directly by the RVA47.320 or by one of the BMUs based on the values adjusted on the RVA47.320.

- The RVA47.320 accepts and handles heat demand signals of additional controllers connected to the LPB, and of controllers delivering their signals via input H1.

## → Note

On the consumer side, the plant can be extended to include up to 16 controllers without an additional bus power supply, and up to 40 controllers when using a central bus power supply (also refer to Basic Documentation LPB System Engineering, reference number CE1P2370E).

On the heat generation side, additional RVA47.320 or RVA43.222 can be used to build up a cascade of up to 16 heat sources (modulating, multi-stage or mixed).

---

## Hydraulic circuit

Where shown, the applications require proper hydraulic decoupling between heat generation and heat consumption since the volumetric flows on both sides vary and are different from one another. The simplest hydraulic decoupling method is the use of a sufficiently large pressureless header (bypass, hydraulic decoupler; about two to three nominal sizes larger than the header of the boiler circuit).

With plant types using no boiler pump, a flow switch is required to ensure the flow of water through the boiler.

When using heating boilers with a speed controlled pump, the pump must be set to a fixed speed.

## → Important

When designing the plant, it should be made certain that the volumetric flows on the heat generation and heat consumption side at nominal output are about the same.

---

## Outside sensor

The outside sensor can be connected either directly to the RVA47.320 or to one of the BMUs to transmit its value to the controller via the PPS. But it can also be connected to another LPB-compatible controller to transmit its value via the LPB- to the other LPB-compatible controllers.

We recommend to connect it directly to the RVA47.320.

---

## D.h.w. priority

When using d.h.w. heating with a charging pump, d.h.w. priority is possible only in connection with LPB capable controller. Controllers not suited for use with the LPB cannot be acted upon.

## 7.1 Plant types RVA47.320 - no. 27

→ Note

The plant type no. is identical with the number displayed on line 53.

### Hydraulic circuit

Control of a single BMU or cascade control of up to four BMUs No d.h.w. heating via the RVA47.320.

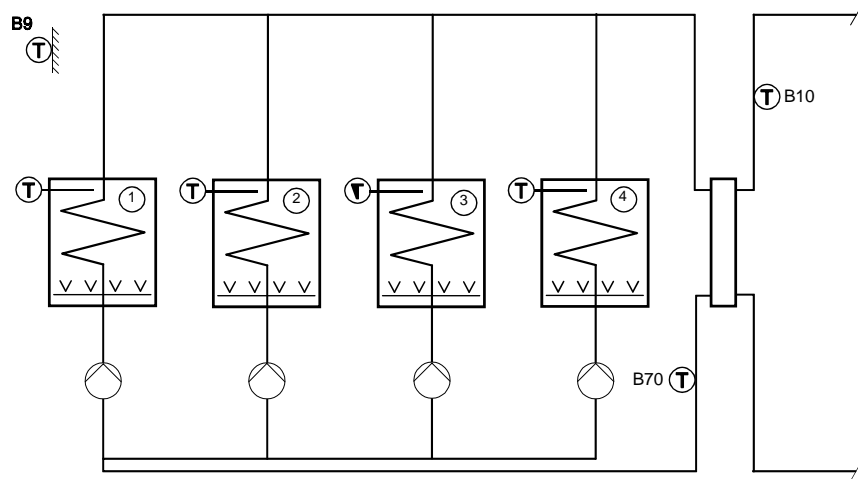

Type of unit  
Display of plant type  
Heating curve (line 17)  
Pump function Q1 (line 95)

| BMU 1 | BMU 2 | BMU 3 | BMU 4 | RVA47.320                           |
|-------|-------|-------|-------|-------------------------------------|
|       |       |       |       | 27                                  |
|       |       |       |       | --- (inactive)                      |
|       |       |       |       | 1 (heating circuit pump or no pump) |

→ Important

This application requires the heat demand signal from a consumer to release heat generation:

- LPB capable controllers signal the RVA47.320 their current heat demand directly via LPB.
- Controllers not suited for use with the LPB can deliver their heat demand signal via input H1.

### Electrical connections

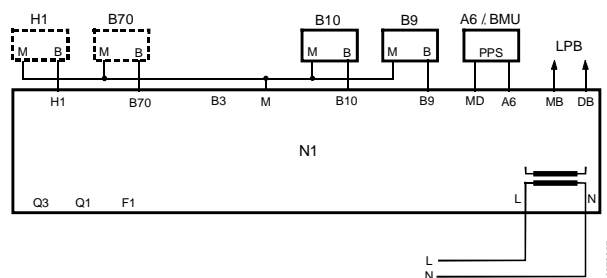

### Legend

For a detailed legend, refer to page 178.

## 7.2 Plant types RVA47.320 - no. 28

→ Note

The plant type no. is identical with the number displayed on line 53.

### Hydraulic circuit

Control of a single BMU or cascade control of up to four BMUs D.h.w. heating with charging pump by the RVA47.320.

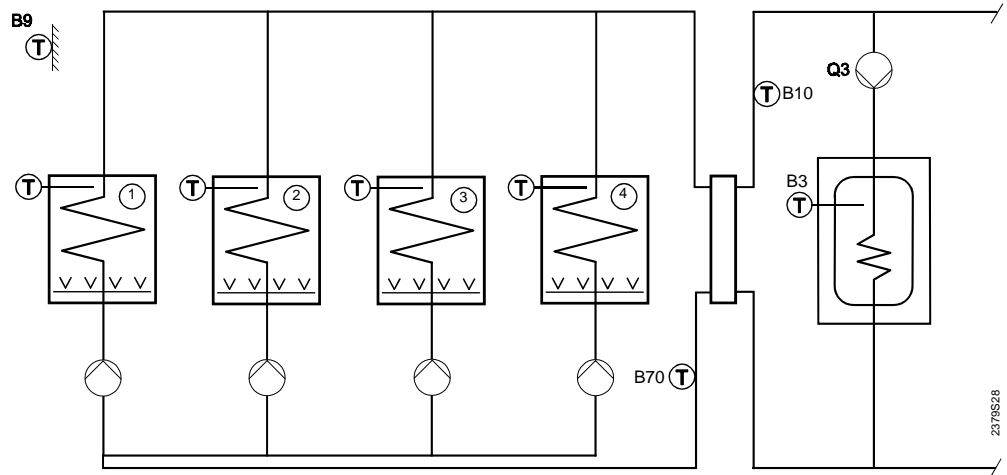

Type of unit  
Display of plant type  
Heating curve (line 17)  
Pump function Q1 (line 95)

| BMU 1 | BMU 2 | BMU 3 | BMU 4 | RVA47.320                     |
|-------|-------|-------|-------|-------------------------------|
|       |       |       |       | <b>28</b>                     |
|       |       |       |       | --- (inactive)                |
|       |       |       |       | 1 (heating circuit pump or no |

→ Important

This application requires the heat demand signal from a consumer (or d.h.w. heating) to release heat generation:

- LPB capable controllers signal the RVA47.320 their current heat demand directly via LPB.
- Controllers not suited for use with the LPB can deliver their heat demand signal via input H1.

### Electrical connections

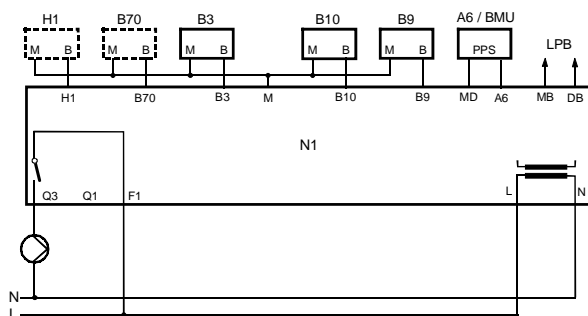

### Legend

For a detailed legend, refer to page 178.

## 7.3 Plant types RVA47.320 - no. 29

→ Note

The plant type no. is identical with the number displayed on line 53.

### Hydraulic circuit

Control of a single BMU or cascade control of up to four BMUs. D.h.w. heating by one BMU, with changeover valve.

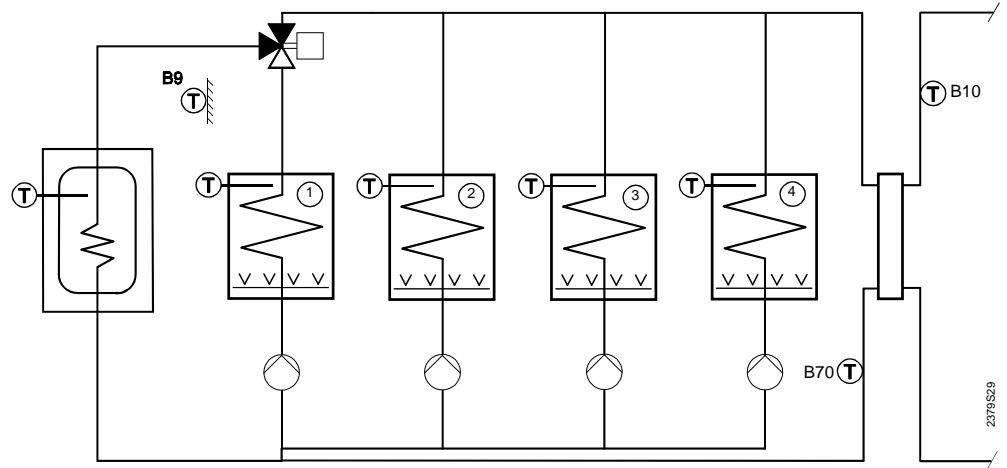

Type of unit  
Display of plant type  
Heating curve (line 17)  
Pump function Q1 (line 95)

|                            | BMU 1 | BMU 2 | BMU 3 | BMU 4 | RVA47.320           |
|----------------------------|-------|-------|-------|-------|---------------------|
| Display of plant type      |       |       |       |       | 29                  |
| Heating curve (line 17)    |       |       |       |       | --- (inactive)      |
| Pump function Q1 (line 95) |       |       |       |       | 1 (heating circuit) |

→ Important

This application requires the heat demand signal from a consumer to release heat generation:

- LPB capable controllers signal the RVA47.320 their current heat demand directly via LPB
- Controllers not suited for use with the LPB can deliver their heat demand signal via input H1

→ Note

A heat demand signal from the d.h.w. storage tank releases only that boiler to which the storage tank is hydraulically connected. The other boilers of the cascade will not be released.

### Electrical connections

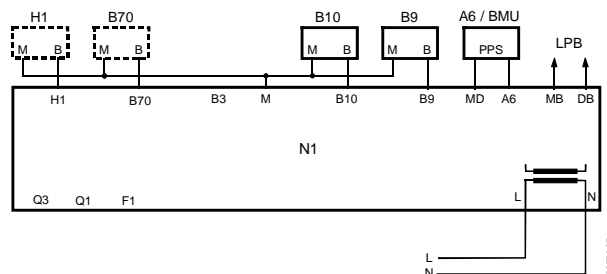

→ Note

The d.h.w. sensor (B3) is connected directly to BMU 1.

### Legend

For a detailed legend, refer to page 178.

## 7.4 Plant types RVA47.320 - no. 30

→ Note

The plant type no. is identical with the number displayed on line 53.

### Hydraulic circuit

Control of a single BMU or cascade control of up to four BMUs Primary pump for heating circuits connected to the RVA47.320. No d.h.w. heating via the RVA47.320.

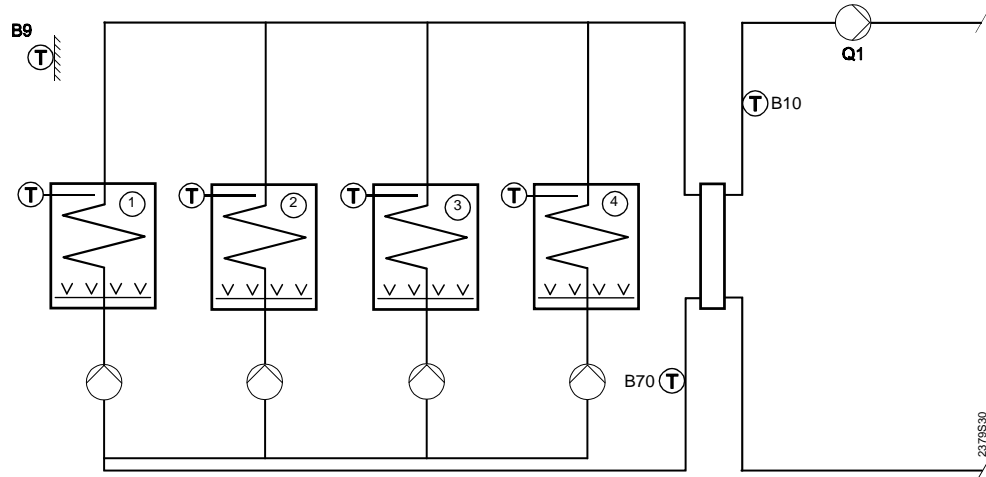

Type of unit  
Display of plant type  
Heating curve (line 17)  
Pump function Q1 (line 95)

| BMU 1 | BMU 2 | BMU 3 | BMU 4 | <b>RVA47.320</b>                                                      |
|-------|-------|-------|-------|-----------------------------------------------------------------------|
|       |       |       |       | <b>30</b>                                                             |
|       |       |       |       | --- (inactiv) or 2.5...40                                             |
|       |       |       |       | 2 (primary pump for HC only) or<br>3 (primary pump for HC and d.h.w.) |

→ Important

Heat generation is released by the heat demand signal from a consumer:

- LPB capable controllers signal the RVA47.320 their current heat demand directly via LPB
- Controllers not suited for use with the LPB can deliver their heat demand signal via input H1

When there is no heat demand signal from the consumers (no LPB capable controllers connected and no possibility to use input H1), the controller itself can generate a weather-compensated flow temperature (adjustment of heating curve with a valid value).

### Electrical connections

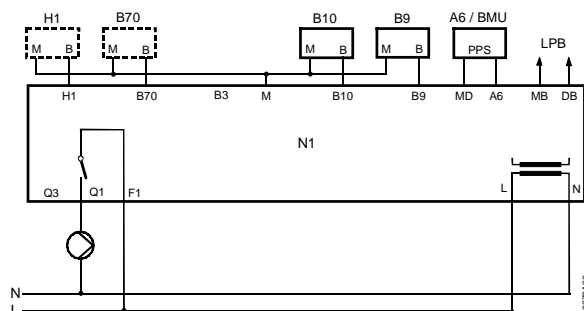

### Legend

For a detailed legend, refer to page 178.

## 7.5 Plant types RVA47.320 - no. 31

→ Note

The plant type no. is identical with the number displayed on line 53.

### Hydraulic circuit

Control of a single BMU or cascade control of up to four BMUs D.h.w. heating with charging pump by RVA47.320. Primary pump for heating circuits and d.h.w. heating connected to RVA47.320.

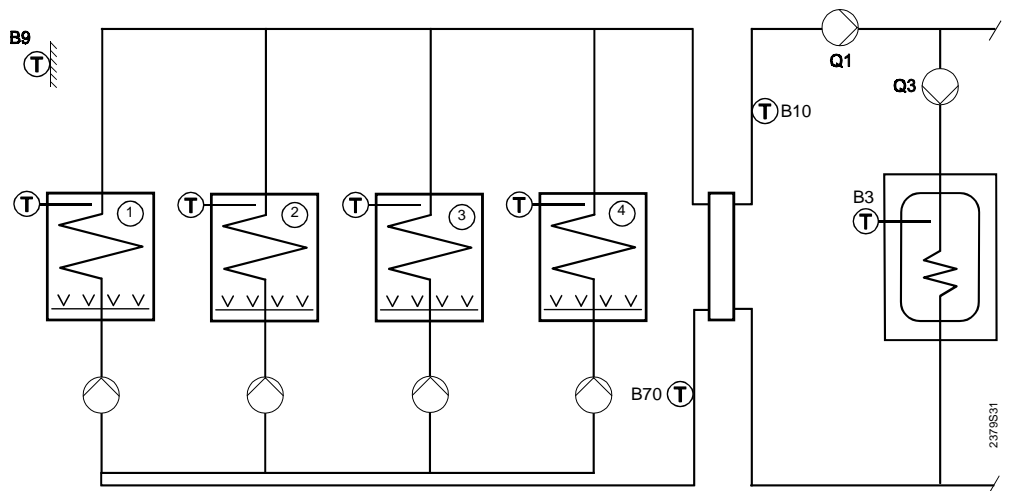

Type of unit  
Display of plant type  
Heating curve (line 17)  
Pump function Q1 (line 95)

| BMU 1 | BMU 2 | BMU 3 | BMU 4 | RVA47.320                          |
|-------|-------|-------|-------|------------------------------------|
|       |       |       |       | 31                                 |
|       |       |       |       | --- (inactive) or 2.5...40         |
|       |       |       |       | 3 (primary pump for HC and d.h.w.) |

→ Important

Heat generation is released by the heat demand signal from a consumer (or d.h.w. heating):

- LPB capable controllers signal the RVA47.320 their current heat demand directly via LPB.
- Controllers not suited for use with the LPB can deliver their heat demand signal via input H1.

When there is no heat demand signal from the consumers (no LPB capable controllers connected and no possibility to use input H1), the controller itself can generate a weather-compensated flow temperature (adjustment of heating curve with a valid value).

### Electrical connections

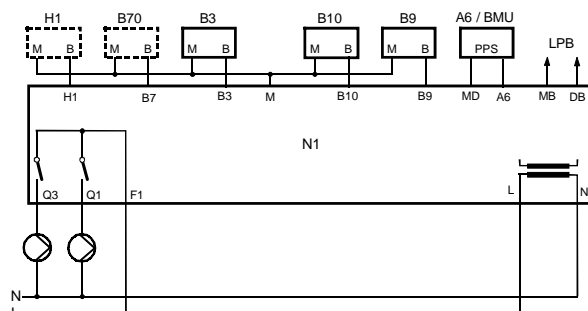

### Legend

For a detailed legend, refer to page 178.

## 7.6 Plant types RVA47.320 - no. 32

→ Note

The plant type no. is identical with the number displayed on line 53.

### Hydraulic circuit

Control of a single BMU or cascade control of up to four BMUs D.h.w. heating with charging pump by RVA47.320. Primary pump for heating circuits connected to the RVA47.320.

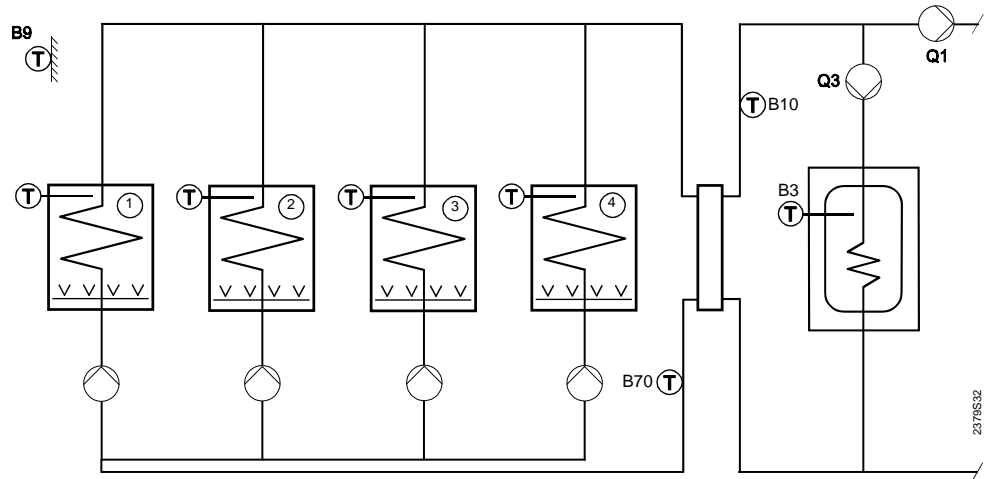

Type of unit  
Display of plant type  
Heating curve (line 17)  
Pump function Q1 (line 95)

| BMU 1 | BMU 2 | BMU 3 | BMU 4 | RVA47.320                     |
|-------|-------|-------|-------|-------------------------------|
|       |       |       |       | <b>32</b>                     |
|       |       |       |       | --- (inactiv) or 2.5...40     |
|       |       |       |       | 2 (primary pump for HCs only) |

→ Important

Heat generation is released by the heat demand signal from a consumer (or d.h.w. heating):

- LPB capable controllers signal the RVA47.320 their current heat demand directly via LPB.
- Controllers not suited for use with the LPB can deliver their heat demand signal via input H1.

When there is no heat demand signal from the consumers (no LPB capable controllers connected and no possibility to use input H1), the controller itself can generate a weather-compensated flow temperature (adjustment of heating curve with a valid value).

### Electrical connections

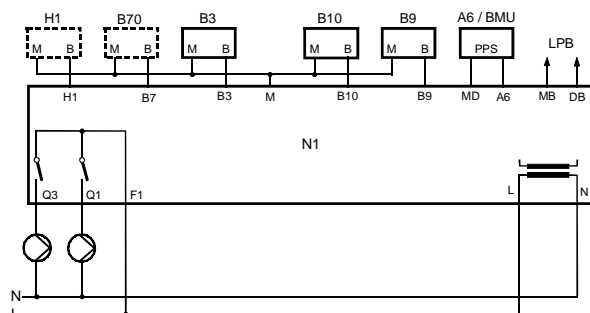

### Legend

For a detailed legend, refer to page 178.

## 7.7 Plant types RVA47.320 - no. 33

→ Note

The plant type no. is identical with the number displayed on line 53.

### Hydraulic circuit

Control of a single BMU or cascade control of up to four BMUs D.h.w. heating by one BMU, with changeover valve. Primary pump for heating circuits connected to the RVA47.320.

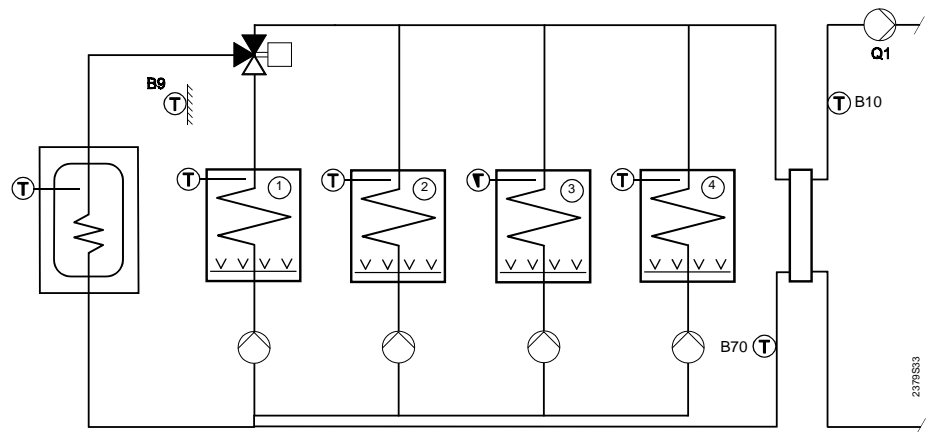

Type of unit  
Display of plant type  
Heating curve (line 17)  
Pump function Q1 (line 95)

| BMU 1 | BMU 2 | BMU 3 | BMU 4 | RVA47.320                          |
|-------|-------|-------|-------|------------------------------------|
|       |       |       |       | <b>33</b>                          |
|       |       |       |       | --- (inactiv) or 2.5...40          |
|       |       |       |       | 2 (primary pump for HC only)       |
|       |       |       |       | 3 (primary pump for HC and d.h.w.) |

→ Important

Heat generation is released by the heat demand signal from a consumer:

- LPB capable controllers signal the RVA47.320 their current heat demand directly via LPB.
- Controllers not suited for use with the LPB can deliver their heat demand signal via input H1.

When there is no heat demand signal from the consumers (no LPB capable controllers connected and no possibility to use input H1), the controller itself can generate a weather-compensated flow temperature (adjustment of heating curve with a valid value).

→ Notes

A heat demand signal from the d.h.w. storage tank releases only that boiler to which the storage tank is hydraulically connected. The other boilers of the cascade will not be released.

### Electrical connections

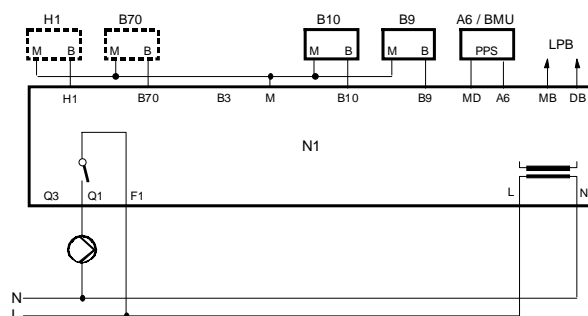

→ Note

The d.h.w. sensor (B3) is connected directly to BMU 1.

### Legend

For a detailed legend, refer to page 178.

## 7.8 Plant types RVA47.320 - no. 34

→ Note

The plant type no. is identical with the number displayed on line 53.

### Hydraulic circuit

Control of a single BMU or cascade control of up to four BMUs. Control of pump heating circuit by the RVA47.320. No d.h.w. heating via the RVA47.320.

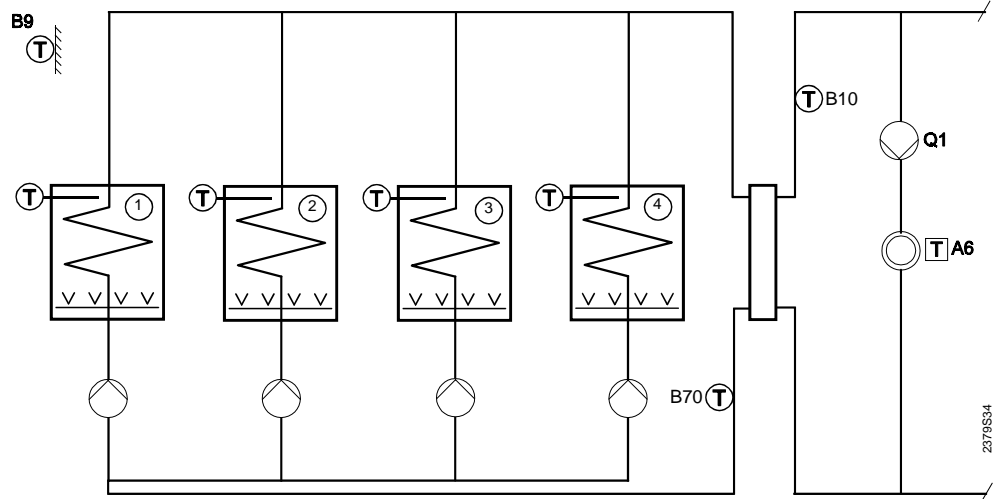

Type of unit  
Display of plant type  
Heating curve (line 17)  
Pump function Q1 (line 95)

| BMU 1 | BMU 2 | BMU 3 | BMU 4 | RVA47.320                |
|-------|-------|-------|-------|--------------------------|
|       |       |       |       | 34                       |
|       |       |       |       | 2.5...40                 |
|       |       |       |       | 1 (heating circuit pump) |

→ Important

Other LPB capable controllers on the consumer side signal the RVA47.320 their current heat demand directly via LPB. Controllers not suited for use with the LPB can deliver their heat demand signal via input H1.

### Electrical connections

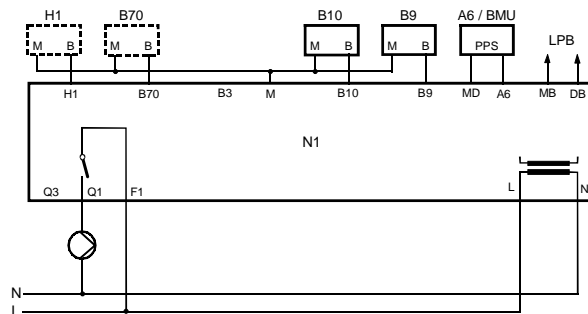

### Legend

For a detailed legend, refer to page 178.

## 7.9 Plant types RVA47.320 - no. 35

→ Note

The plant type no. is identical with the number displayed on line 53.

### Hydraulic circuit

Control of a single BMU or cascade control of up to four BMUs. Control of the pump heating circuit by the RVA47.320. D.h.w. heating with charging pump by the RVA47.320.

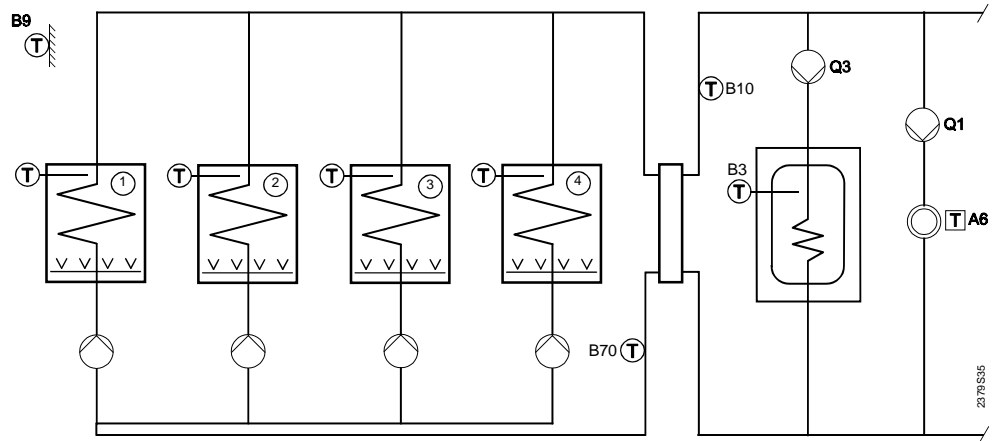

Type of unit  
Display of plant type  
Heating curve (line 17)  
Pump function Q1 (line 95)

| BMU 1 | BMU 2 | BMU 3 | BMU 4 | <b>RVA47.320</b>         |
|-------|-------|-------|-------|--------------------------|
|       |       |       |       | <b>35</b>                |
|       |       |       |       | 2.5...40                 |
|       |       |       |       | 1 (heating circuit pump) |

→ Important

Other LPB capable controllers on the consumer side signal the RVA47.320 their current heat demand directly via LPB.

Controllers not suited for use with the LPB can deliver their heat demand signal via input H1.

### Electrical connections

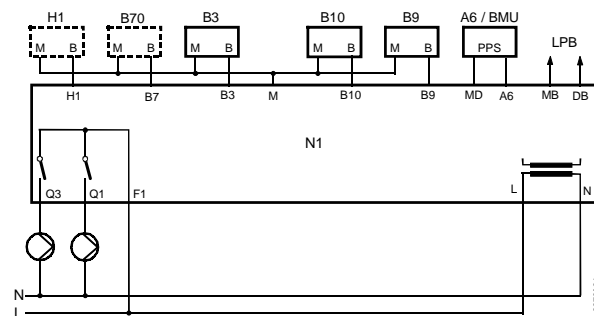

### Legend

For a detailed legend, refer to page 178.

## 7.10 Plant types RVA47.320 - no. 36

→ Note

The plant type no. is identical with the number displayed on line 53.

### Hydraulic circuit

Control of a single BMU or cascade control of up to four BMUs. D.h.w. heating by one BMU, with changeover valve. Control of pump heating circuit by RVA47.320.

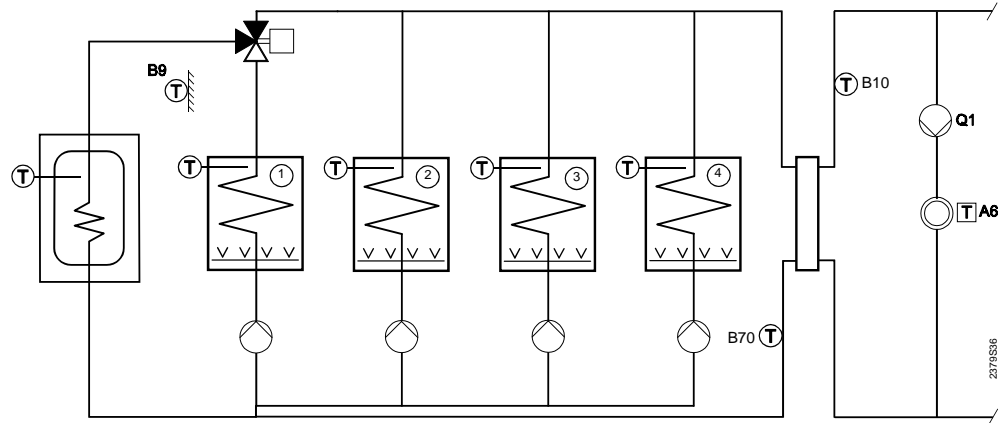

Type of unit  
Display of plant type  
Heating curve (line 17)  
Pump function Q1 (line 95)

| BMU 1 | BMU 2 | BMU 3 | BMU 4 | RVA47.320                |
|-------|-------|-------|-------|--------------------------|
|       |       |       |       | 36                       |
|       |       |       |       | 2.5...40                 |
|       |       |       |       | 1 (heating circuit pump) |

→ Important

Other LPB capable controllers on the consumer side signal the RVA47.320 their current heat demand directly via LPB.

Controllers not suited for use with the LPB can deliver their heat demand signal via input H1.

→ Notes

When there is only a heat demand signal from the d.h.w. storage tank (heating circuits do not currently call for heat), the boiler put into operation is only that to which the storage tank is hydraulically connected. The other boilers of the cascade will not be released.

### Electrical connections

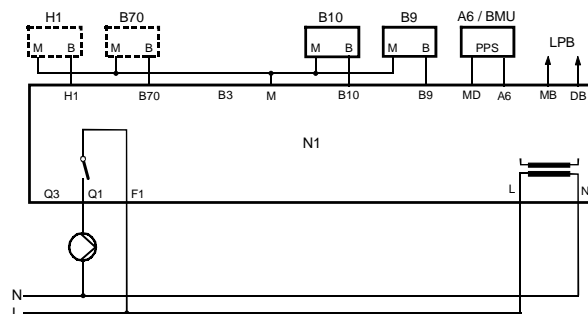

→ Note

The d.h.w. sensor (B3) is connected directly to BMU 1.

### Legend

For a detailed legend, refer to page 178.

## 7.11 Plant types RVA47.320 - no. 65

→ Note

The plant type no. is identical with the number displayed on line 53.

### Hydraulic circuit

Control of a single BMU or cascade control of up to four BMUs. Control of the pump heating circuit by the RVA47.320 based on the heat demand signal received via input H1.

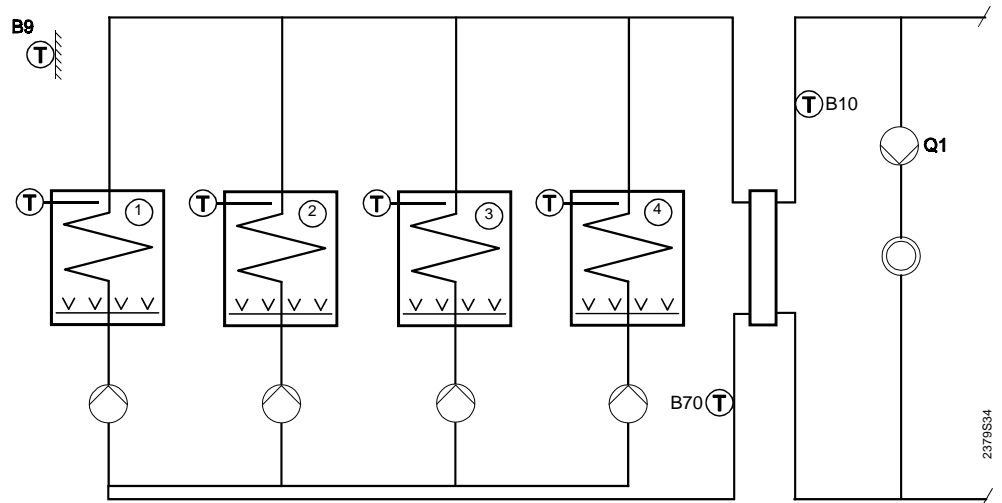

Type of unit  
Display of plant type  
Heating curve (line 17)  
Pump function Q1 (line 95)

| BMU 1 | BMU 2 | BMU 3 | BMU 4 | RVA47.320                 |
|-------|-------|-------|-------|---------------------------|
|       |       |       |       | 65                        |
|       |       |       |       | --- (inactiv) or 2.5...40 |
|       |       |       |       | 5 (H1-Pumpe)              |

→ Important

Other LPB capable controllers on the consumer side signal the RVA47.320 their current heat demand directly via LPB.

The heat demand signal for the pump heating circuit is generated via input H1.

In addition, the controller itself can generate a weather-compensated flow temperature (setting the heating curve to a valid value).

### Electrical connections

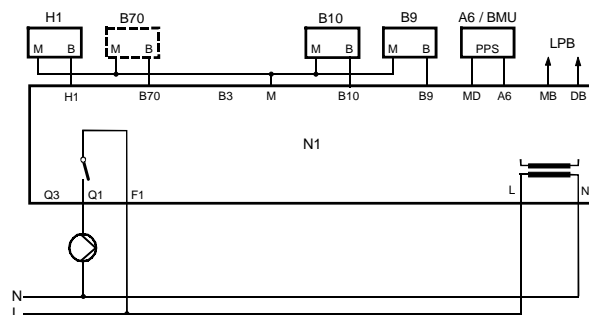

### Legend

For a detailed legend, refer to page 178.

## 7.12 Plant types RVA47.320 - no. 66

→ Note

The plant type no. is identical with the number displayed on line 53.

### Hydraulic circuit

Control of a single BMU or cascade control of up to four BMUs. D.h.w. heating with charging pump by the RVA47.320. Control of the pump heating circuit by the RVA47.320 based on the heat demand signal received via input H1.

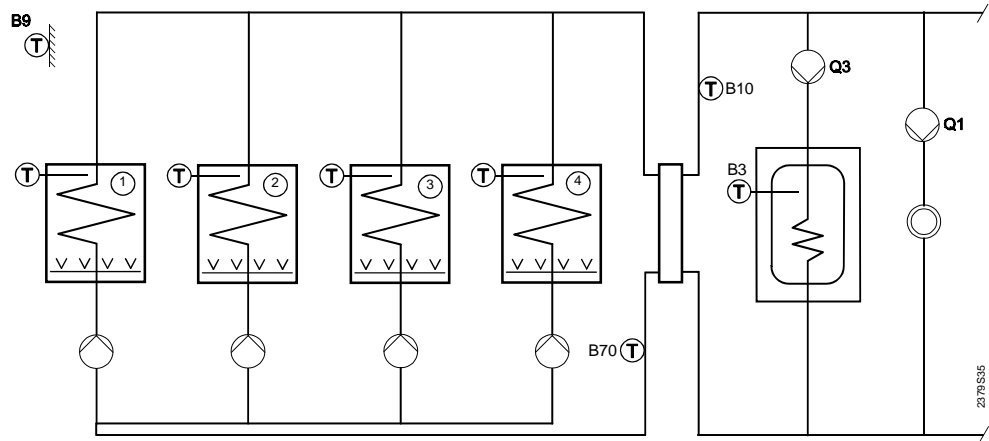

Type of unit  
Display of plant type  
Heating curve (line 17)  
Pump function Q1 (line 95)

| BMU 1 | BMU 2 | BMU 3 | BMU 4 | RVA47.320                 |
|-------|-------|-------|-------|---------------------------|
|       |       |       |       | 66                        |
|       |       |       |       | --- (inactiv) or 2.5...40 |
|       |       |       |       | 5 (H1-Pumpe)              |

→ Important

Other LPB capable controllers on the consumer side signal the RVA47.320 their current heat demand directly via LPB.

The heat demand signal for the pump heating circuit is generated via input H1.

In addition, the controller itself can generate a weather-compensated flow temperature (setting the heating curve to a valid value).

### Electrical connections

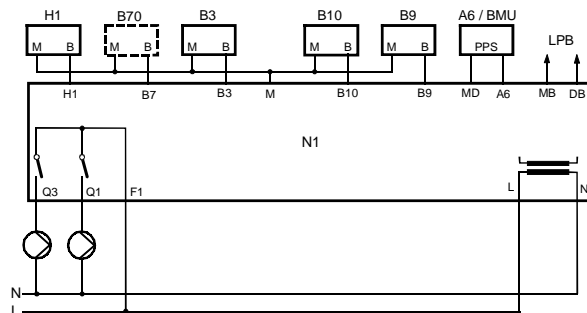

### Legend

For a detailed legend, refer to page 178.

## 7.13 Plant types RVA47.320 - no. 67

→ Note

The plant type no. is identical with the number displayed on line 53.

### Hydraulic circuit

Control of a single BMU or cascade control of up to four BMUs. D.h.w. heating by one BMU, with changeover valve. Control of the pump heating circuit by the RVA47.320 based on the heat demand signal received via input H1.

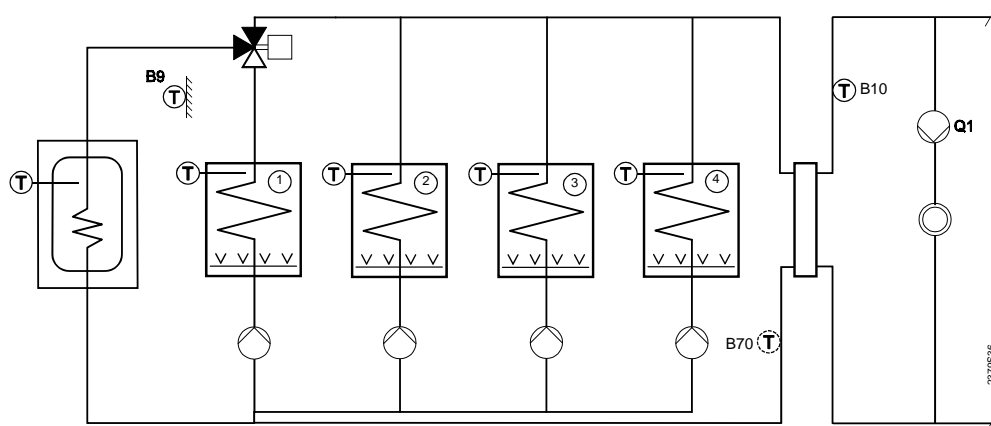

Type of unit  
Display of plant type  
Heating curve (line 17)  
Pump function Q1 (line 95)

| BMU 1 | BMU 2 | BMU 3 | BMU 4 | RVA47.320                 |
|-------|-------|-------|-------|---------------------------|
|       |       |       |       | <b>67</b>                 |
|       |       |       |       | --- (inactiv) or 2.5...40 |
|       |       |       |       | 5 (H1-Pumpe)              |

→ Important

Other LPB capable controllers on the consumer side signal the RVA47.320 their current heat demand directly via LPB.

The heat demand signal for the pump heating circuit is generated via input H1.

In addition, the controller itself can generate a weather-compensated flow temperature (setting the heating curve to a valid value).

→ Notes

When there is only a heat demand signal from the d.h.w. storage tank (heating circuits do not currently call for heat), the boiler put into operation is only that to which the storage tank is hydraulically connected. The other boilers of the cascade will not be released.

### Electrical connections

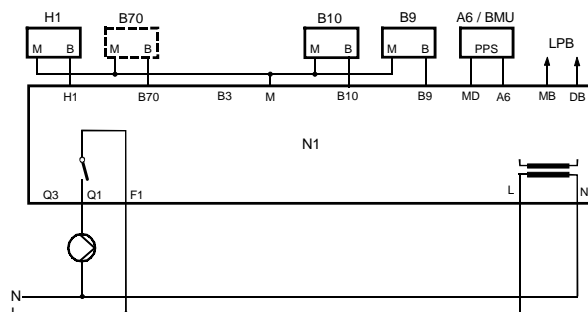

→ Note

The d.h.w. sensor (B3) is connected directly to BMU 1.

### Legend

For a detailed legend, refer to page 178.

## 7.14 Legend

| Low voltage side |                                                        | Mains voltage side |                                                                              |
|------------------|--------------------------------------------------------|--------------------|------------------------------------------------------------------------------|
| DB               | Data bus (LPB)                                         | N                  | Neutral (mains connection)                                                   |
| MB               | Ground bus (LPB)                                       | L                  | Live AC 230 V (mains connection)                                             |
| A6               | PPS (room unit, BMU...)                                | F1                 | Line control contact relay Q1/Q3                                             |
| MD               | Ground PPS                                             | Q1                 | Heating circuit pump / primary pump                                          |
| B9               | Outside sensor                                         | Q3                 | D.h.w. charging pump                                                         |
| B10              | Cascade flow temperature sensor                        |                    |                                                                              |
| B70              | Cascade return temperature sensor                      |                    |                                                                              |
| M                | Ground sensor                                          |                    |                                                                              |
| B3               | D.h.w. temperature sensor / control thermostat         |                    |                                                                              |
| H1               | Input H1                                               |                    |                                                                              |
| LPB              | Local Process Bus<br>(ALBATROS™-process bus)           | N1                 | ALBATROS™controller RVA47.320                                                |
| PPS              | Point-to-point interface<br>(ALBATROS™ peripheral bus) | BMU                | Boiler Management Unit (burner control with additional management functions) |

The connection diagrams show optional components with broken lines.

For application examples with a cascade integrated in systems with alternative heat generation, refer to Basic Documentation "LPB System Engineering" (document no. CE1P2370E).

# 8 Dimensions

## Controller

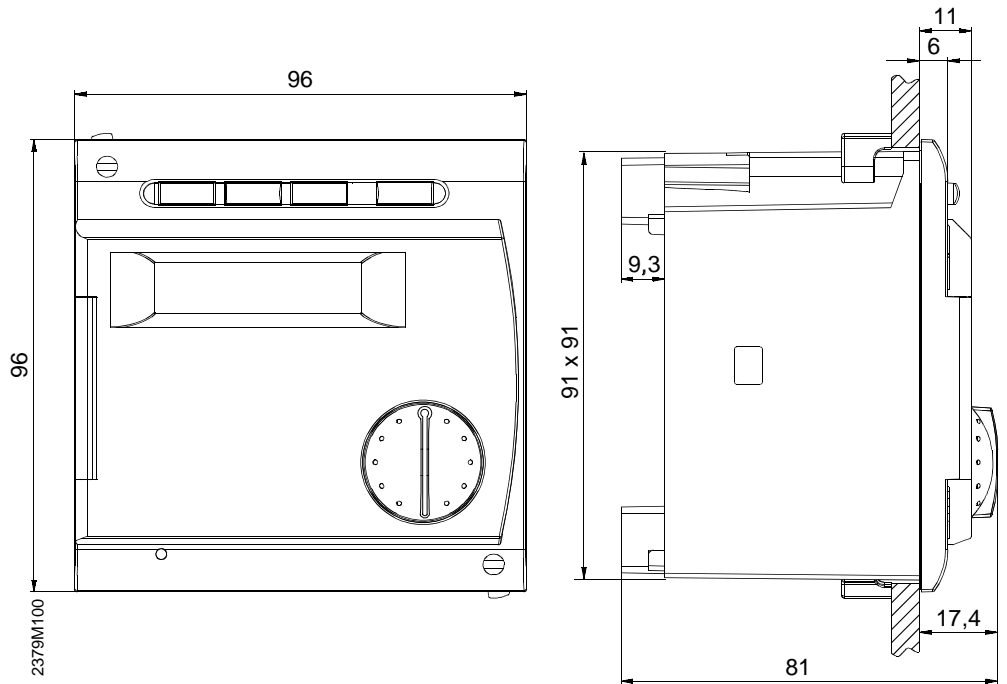

## Panel cutout

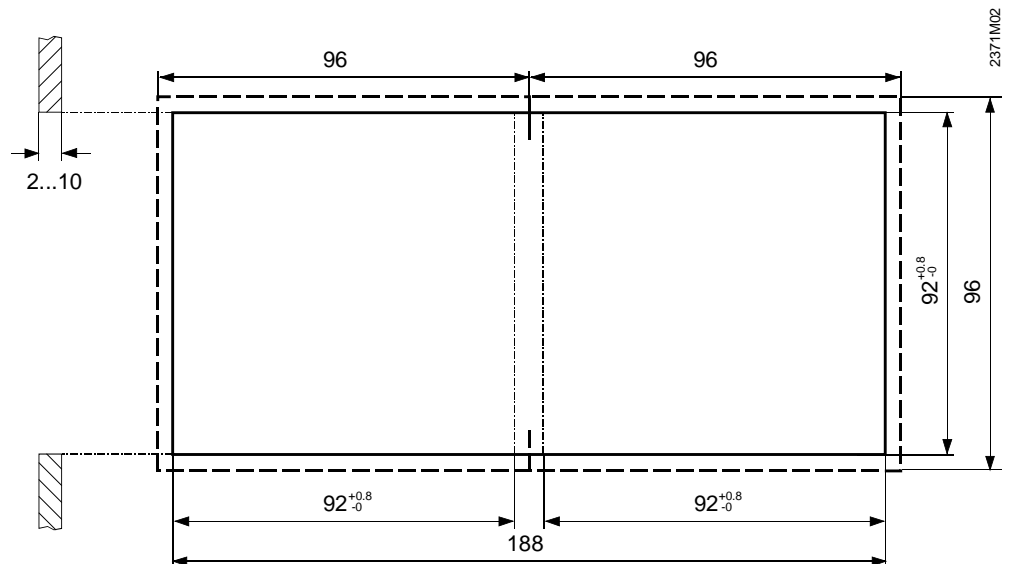

## 9 Technical data

|                            |                                                                                                       |                                              |
|----------------------------|-------------------------------------------------------------------------------------------------------|----------------------------------------------|
| Power supply               | Nominal voltage                                                                                       | AC 230 V (±10 %)                             |
|                            | Nominal frequency                                                                                     | 50 Hz (±6 %)                                 |
|                            | Power consumption                                                                                     | max. 7 VA                                    |
| Requirements               | Safety class<br>(when mounted properly)                                                               | II, to EN 60730                              |
|                            | Degree of protection<br>(when mounted properly)                                                       | IP 40 to EN 60529                            |
|                            | Electromagnetic immunity                                                                              | conforming to the requirements of EN 50082-2 |
|                            | Electromagnetic emissions                                                                             | conforming to the requirements of EN 50081-1 |
| Climatic conditions        | Operation to IEC 721-3-3                                                                              | class 3K5 0...50 °C<br>(non-condensing)      |
|                            | Storage to IEC 721-3-1                                                                                | Class 1K3 -25...70 °C                        |
|                            | Transport to IEC 721-3-2                                                                              | Class 2K3 -25...70 °C                        |
| Contamination              | To EN60730                                                                                            | usual environment                            |
| Mechanical prerequisite:   | Operation to IEC 721-3-3                                                                              | Class 3M2                                    |
|                            | Storage to IEC 721-3-1                                                                                | Class 1M2                                    |
|                            | Transport to IEC 721-3-2                                                                              | Class 2M2                                    |
| Mode of operation          | To EN 60730 par. 11.4 11.4                                                                            | 1b                                           |
| Output relays              | Voltage range                                                                                         | AC 24...230 V<br>no safety extra low voltage |
|                            | Nominal current                                                                                       | at 24 V: 20 mA...2 A,<br>(cos phi > 0,7)     |
|                            | Switch-on peak                                                                                        | max. 10 A, max. 1 s                          |
|                            | Fusing                                                                                                | max. 10 A                                    |
| Bus extension              | Perm. cable length for PPS:<br>(Telephone wire 0.8 mm dia., 2-wire interchangeable)                   |                                              |
|                            | Max. line length central unit / peripheral unit                                                       | 75 m                                         |
|                            | Max. total cable length (sum of all branches)                                                         | 250 m                                        |
|                            | Perm. cable length for LPB:<br>(copper cable 1.5 mm <sup>2</sup> , 2-wire <b>not</b> interchangeable) |                                              |
|                            | With controller bus power supply (per controller)                                                     | 250 m                                        |
|                            | With central bus power supply (bus power supply / controller)                                         | 460 m                                        |
|                            | Bus loading number                                                                                    | E = 3                                        |
| Perm. sensor cable lengths | 0.6 mm dia.                                                                                           | max. 20 m                                    |
|                            | 1.0 mm <sup>2</sup>                                                                                   | max. 80 m                                    |
|                            | 1.5 mm <sup>2</sup>                                                                                   | max. 120 m                                   |

|               |                                                               |                                                                                            |
|---------------|---------------------------------------------------------------|--------------------------------------------------------------------------------------------|
| Inputs        | Outside sensor                                                | NTC (QAC31) or<br>Ni 1000 (QAC21)                                                          |
|               | D.h.w. temperature sensor                                     | Ni 1000 $\Omega$ at 0 °C (QAZ21)                                                           |
|               | Cascade flow temperature sensor                               | Ni 1000 $\Omega$ at 0 °C (QAD21)                                                           |
|               | Cascade return temperature sensor                             | Ni 1000 $\Omega$ at 0 °C (QAD21)                                                           |
|               | Buffer storage tank temperature sensor                        | Ni 1000 $\Omega$ at 0 °C (QAZ21)                                                           |
|               | H1 as an analog input with<br>Safety extra low voltage (SELV) | $U_{H1} = (12...24) V$<br>(contact open)<br>$I_{H1} = (2...5) mA$<br>(contact closed)      |
|               | H1 as an analog input with<br>safety extra low voltage (SELV) | $U_{in} = (0...10 V)$ für 0...130 °C<br>$R_{in} = 100 k\Omega$<br>max. ratings 20 V; 20 mA |
| Miscellaneous | Reserve                                                       | > 12 hours                                                                                 |
|               | Weight                                                        | approx. 0.5 kg                                                                             |
|               | Software class to EN 60730                                    | Klasse A                                                                                   |

# Index

## A

|                                                                      |          |
|----------------------------------------------------------------------|----------|
| absolute priority.....                                               | 103      |
| actual value of boiler temperature .....                             | 64       |
| actual value of buffer storage tank temperature .....                | 67       |
| actual value of cascade flow temperature .....                       | 65       |
| actual value of cascade return temperature .....                     | 66       |
| actual value of d.h.w. temperature .....                             | 67       |
| actual value of outside temperature .....                            | 51       |
| actual value of room temperature.....                                | 51       |
| adaptation heating curve.....                                        | 92       |
| adaptation of heating curve.....                                     | 92       |
| adaptation of the heating curve in function 1.....                   | 137      |
| adaptation of the heating curve in function 2.....                   | 138      |
| adaptation sensitivity 1.....                                        | 137      |
| adaptation sensitivity 2.....                                        | 138      |
| assignment of d.h.w. heating.....                                    | 98       |
| attenuated outside temperature .....                                 | 68       |
| automatic 24-hour heating limit .....                                | 156      |
| automatic 24-hour heating limit with room temperature influence..... | 156, 158 |
| automatic adaptation.....                                            | 92       |
| automatic summer / winter changeover .....                           | 116      |

## B

|                                          |     |
|------------------------------------------|-----|
| BMU boiler temperature setpoint.....     | 71  |
| boiler temperature setpoint of BMUs..... | 71  |
| boost heating .....                      | 132 |
| boost of flow temperature setpoint ..... | 102 |
| boost of room temperature setpoint ..... | 132 |
| buffer storage tank temperature .....    | 83  |
| building's thermal dynamics .....        | 91  |
| burner operating hours BMU 1 – 4 .....   | 79  |
| bus power supply .....                   | 113 |
| bus power supply via controllers .....   | 113 |

## C

|                                                      |          |
|------------------------------------------------------|----------|
| calibration of actual output range of BMU 1 -4 ..... | 129      |
| cascade management strategy .....                    | 144      |
| cascade return temperature sensor .....              | 66       |
| cascade sensor.....                                  | 65       |
| central bus power supply .....                       | 113      |
| central changeover.....                              | 115      |
| central standby switch.....                          | 117      |
| changeover of boiler sequence .....                  | 108      |
| changeover of boiler sequence in a cascade .....     | 107      |
| changeover of operating mode.....                    | 120      |
| chimney sweep .....                                  | 121, 154 |
| clock mode.....                                      | 118      |
| clock setting .....                                  | 40, 118  |
| common flow temperature sensor .....                 | 65       |
| common return temperature sensor .....               | 66       |
| communication status .....                           | 114      |
| communication via BUS.....                           | 114      |
| communication via LPB.....                           | 111      |

|                                     |               |
|-------------------------------------|---------------|
| composite outside temperature ..... | 69            |
| constant for quick setback.....     | 131           |
| contact H1 .....                    | 119, 123, 124 |
| continuous display.....             | 152           |
| control of the burner .....         | 155           |

## D

|                                                   |          |
|---------------------------------------------------|----------|
| d.h.w temperature setpoint.....                   | 73       |
| d.h.w. priority.....                              | 103      |
| d.h.w. push.....                                  | 160      |
| d.h.w. temperature control.....                   | 140      |
| d.h.w. temperature sensor.....                    | 100      |
| d.h.w.frost protection .....                      | 163      |
| day .....                                         | 40       |
| demand for heat .....                             | 119, 122 |
| demand for heat with reduced d.h.w. setpoint..... | 106      |
| device address .....                              | 77, 111  |
| Device address .....                              | 78       |
| device operating hours .....                      | 153      |
| device subaddress .....                           | 78       |
| device subaddress .....                           | 77       |
| dimensions .....                                  | 179      |
| dimensions of cutout .....                        | 15       |
| display boiler temperature setpoint.....          | 71       |
| display boilers.....                              | 77       |
| display cascade flow temperature .....            | 72       |
| display d.h.w temperature setpoint.....           | 73       |
| display flow temperature setpoint .....           | 76       |
| display lead boiler.....                          | 78       |
| display of actual values .....                    | 51       |
| display of LPB communication .....                | 114      |
| display of LPB power supply .....                 | 114      |
| display of nominal room temperature setpoint..... | 74       |
| display of plant type.....                        | 60       |
| display of PPS communication.....                 | 62       |

## E

|                                                  |     |
|--------------------------------------------------|-----|
| effect of room unit.....                         | 35  |
| ER display .....                                 | 56  |
| exemption of boilers .....                       | 108 |
| exemption with changeover of the boiler sequence | 108 |
| existing boilers.....                            | 77  |

## F

|                                                        |          |
|--------------------------------------------------------|----------|
| fixed changeover of boiler sequence.....               | 109      |
| flow temperature.....                                  | 49       |
| flow temperature setpoint .....                        | 76       |
| frost protection .....                                 | 163      |
| boiler .....                                           | 163      |
| d.h.w. ....                                            | 163      |
| frost protection for the boiler.....                   | 163      |
| frost protection for the building .....                | 46       |
| frost protection for the plant.....                    | 103, 133 |
| with weather-compensation .....                        | 133      |
| frost protection setpoint of the room temperature..... | 46       |

|          |                                                                   |               |
|----------|-------------------------------------------------------------------|---------------|
| <b>G</b> | gain factor for room temperature influence .....                  | 86, 130       |
|          | generation of boiler temperature setpoint .....                   | 155           |
| <b>H</b> | heat gains .....                                                  | 136           |
|          | heat generation lock .....                                        | 121           |
|          | heating circuit operating modes .....                             | 34            |
|          | heavy building structures .....                                   | 91            |
|          | hours run counter for changeover of boiler sequence .....         | 79            |
| <b>I</b> | indication of BMU error code .....                                | 55            |
|          | indication of faults .....                                        | 56            |
|          | input B70/B4 .....                                                | 83            |
|          | input H1 .....                                                    | 119           |
|          | input test .....                                                  | 59            |
| <b>K</b> | KON .....                                                         | 131           |
|          | KORR .....                                                        | 130           |
| <b>L</b> | lag boiler .....                                                  | 107           |
|          | switch-on delay .....                                             | 110           |
|          | lag boiler operation .....                                        | 145           |
|          | lead boiler .....                                                 | 107, 109      |
|          | lead boiler display .....                                         | 78            |
|          | legionella function .....                                         | 142           |
|          | light building structures .....                                   | 91            |
|          | locking signal .....                                              | 104           |
|          | LPB device address .....                                          | 111           |
|          | LPB segment address .....                                         | 112           |
|          | LPB supply .....                                                  | 113           |
| <b>M</b> | management strategy cascade .....                                 | 144           |
|          | mandatory time on basic stage .....                               | 150           |
|          | manual operation .....                                            | 39, 126       |
|          | master .....                                                      | 115, 117, 118 |
|          | maximum limit of output range (Pmax) .....                        | 149           |
|          | maximum limitation of boiler temperature setpoint ..              | 126           |
|          | maximum limitation of flow temperature setpoint .....             | 90            |
|          | maximum nominal setpoint of d.h.w. temperature ..                 | 139           |
|          | maximum value of heat demand signal DC 0...10 V .....             | 124           |
|          | minimum limit of output range .....                               | 148           |
|          | minimum limit of output range (Pmin) .....                        | 148           |
|          | minimum limitation of boiler temperature .....                    | 80            |
|          | minimum limitation of boiler temperature setpoint... ..           | 125           |
|          | minimum limitation of flow temperature setpoint .....             | 89            |
|          | minimum limitation of the boiler return temperature ..            | 128           |
|          | minimum setpoint of flow temperature - contact H1 ..              | 123           |
|          | minimum temperature differential at the pressureless header ..... | 151           |
|          | modem .....                                                       | 120           |
|          | mounting location .....                                           | 13            |
|          | mounting procedure .....                                          | 13            |
|          | mounting the controller .....                                     | 13            |
| <b>N</b> | nominal output of BMU 1 - 4 .....                                 | 81            |
|          | nominal room temperature setpoint .....                           | 37            |
|          | nominal setpoint of d.h.w. temperature .....                      | 44            |
|          | number of d.h.w. charging cycles .....                            | 99            |
| <b>O</b> | operating action of contact H1 .....                              | 124           |
|          | operating elements .....                                          | 32            |
|          | operating mode of d.h.w. heating .....                            | 36            |
|          | operating modes of heating circuit .....                          | 34            |
|          | operational faults .....                                          | 33            |
|          | outdoor heating .....                                             | 103           |
|          | output calibration .....                                          | 129           |
|          | output Q1 .....                                                   | 82            |
|          | output test .....                                                 | 18, 58        |
|          | outside temperature source .....                                  | 70            |
|          | overtemperature protection .....                                  | 134           |
|          | overview of pump operation .....                                  | 162           |
| <b>P</b> | panel cutout .....                                                | 179           |
|          | parallel displacement heating curve .....                         | 85            |
|          | parallel displacement of heating curve .....                      | 85            |
|          | parameter                                                         |               |
|          | heating engineer .....                                            | 23, 25, 30    |
|          | parameter settings for OEM .....                                  | 28            |
|          | parameter settings for the end-user .....                         | 22            |
|          | parameter settings for the heating engineer .....                 | 24            |
|          | plant susceptible to frost .....                                  | 103           |
|          | plant types RVA47.320 .....                                       | 165           |
|          | PPS communication .....                                           | 62            |
|          | preselection of weekday .....                                     | 41, 53        |
|          | pressureless header .....                                         | 151           |
|          | proneness to lime build-up .....                                  | 139           |
|          | protection against boiler overtemperatures .....                  | 127           |
|          | protection against discharging after d.h.w. heating ..            | 161           |
|          | protection against discharging of d.h.w. .....                    | 143           |
|          | protection against legionella viruses .....                       | 142           |
|          | protection against scalding .....                                 | 139           |
|          | pump function output Q1 .....                                     | 82            |
|          | pump heating circuit .....                                        | 134           |
|          | pump kick .....                                                   | 161           |
|          | pump overrun time .....                                           | 127           |
| <b>Q</b> | quick setback constant .....                                      | 131           |
|          | quick setback with a room temperature sensor .....                | 159           |
|          | quick setback: no room temperature detector .....                 | 131           |
| <b>R</b> | range of action .....                                             | 116           |
|          | range of action of central changeover .....                       | 115           |
|          | rectification of faults .....                                     | 33            |
|          | reduced room temperature setpoint .....                           | 45            |

|                                                    |        |                                                 |          |
|----------------------------------------------------|--------|-------------------------------------------------|----------|
| reduced setpoint of d.h.w. temperature .....       | 94     | switching differential of room temperature..... | 87       |
| regulations for installation .....                 | 13, 16 | switching program circulating pump .....        | 97       |
| relay test .....                                   | 58     | switching times .....                           | 43       |
| release of d.h.w. heating .....                    | 95     | switch-on delay of BMU's .....                  | 110      |
| remote telephone switch .....                      | 120    | system standby .....                            | 117      |
| residual heat in the boiler .....                  | 127    | system time .....                               | 118      |
| restart lock of BMUs .....                         | 110    | <b>T</b>                                        |          |
| return temperature .....                           | 83     | technical data .....                            | 180      |
| room temperature limitation.....                   | 87     | temperature-time integral                       |          |
| room temperature setpoint .....                    | 75     | d.h.w. priority.....                            | 105      |
| room unit .....                                    | 62     | terminal H1 .....                               | 119      |
| running time strategy.....                         | 146    | test sequence .....                             | 58       |
| running time strategy.....                         | 144    | time of day.....                                | 40       |
| <b>S</b>                                           |        | time switch program for d.h.w. heating.....     | 53       |
| segment address.....                               | 112    | time switch program for space heating.....      | 41       |
| segment controller.....                            | 111    | time synchronization.....                       | 118      |
| with master function.....                          | 111    | TKmin.....                                      | 80       |
| setpoint boost for d.h.w. heating .....            | 102    | type of building construction .....             | 91       |
| setpoint of legionella function.....               | 142    | type of d.h.w. demand .....                     | 100      |
| setpoint of the cascade flow temperature.....      | 72     | type of lead boiler operation .....             | 144, 145 |
| setting the clock .....                            | 40     | <b>U</b>                                        |          |
| shifting priority .....                            | 104    | use of several controllers .....                | 15       |
| shortened heating up time.....                     | 132    | use sensor input B70/B4 .....                   | 83       |
| slope of heating curve .....                       | 49     | <b>V</b>                                        |          |
| software version .....                             | 153    | voltage signal .....                            | 119      |
| standard times .....                               | 52     | <b>W</b>                                        |          |
| standard values.....                               | 52     | weekday .....                                   | 40       |
| standby switch .....                               | 117    | winter operation.....                           | 47       |
| summer / winter changeover temperature.....        | 47     | wiring.....                                     | 16       |
| summer operation .....                             | 47     |                                                 |          |
| switching differential of d.h.w. ....              | 140    |                                                 |          |
| switching differential of d.h.w. temperature ..... | 140    |                                                 |          |

# Corrigenda

Changes made between editions 1.1 (dated October 15, 1998) and 2.0 (present edition):

The document has been completely revised. For this reason, the corrigenda is not as important and practical as usual. Nevertheless, we made an attempt to provide an overview of the most significant functional changes. Chapter "Overview" at the beginning of the document is very helpful in this respect.

| §   | Location:         | Modification:                                                                                                                                                                                                                          |
|-----|-------------------|----------------------------------------------------------------------------------------------------------------------------------------------------------------------------------------------------------------------------------------|
|     | <u>General</u>    | - Various text corrections of a cosmetic nature                                                                                                                                                                                        |
| 1.  | <u>Chapter 1:</u> | - Overview of new functionality: it is possible to create cascades with up to 16 modulating or multi-stage BMUs / boilers. New are mixed cascades with up to 16 heat sources<br>- New RVA43.222 (C-series) has been added to the range |
| 2.  | <u>Chapter 2:</u> | - Markings of connection terminals have been matched<br>- Layout of parameter list has been changed / some parameters have been cancelled / shifted / newly added                                                                      |
| 3.  | <u>Chapter 3:</u> | - Various parameters have been cancelled / shifted / newly added                                                                                                                                                                       |
| 4.  | <u>Chapter 4:</u> | - Various parameters have been cancelled / shifted / newly added                                                                                                                                                                       |
| 5.  | <u>Chapter 5:</u> | - Various parameters have been cancelled / shifted / newly added                                                                                                                                                                       |
| 6.  | <u>Chapter 6:</u> | - Various parameters have been cancelled / shifted / newly added                                                                                                                                                                       |
| 7.  | <u>Chapter 7:</u> | - Texts / presentations / electrical connections have been modified                                                                                                                                                                    |
| 8.  | <u>Chapter 8:</u> | - No changes                                                                                                                                                                                                                           |
| 9.  | <u>Chapter 9:</u> | - Text modifications                                                                                                                                                                                                                   |
| 10. | <u>Appendix</u>   | - Corrigenda                                                                                                                                                                                                                           |





Siemens Building Technologies AG  
Landis & Staefa Division  
Gubelstrasse 22  
CH 6301 Zug  
Tel. 41 41-724 24 24  
Fax 41 41-724 35 22  
[www.landisstaefa.com](http://www.landisstaefa.com)

© Siemens Building Technologies AG  
Subject to alteration